

Practice Book *UNIT 1 Logic*

Answers

1.1 Logic Puzzles

1.

| | <i>Goldfish</i> | <i>Dog</i> | <i>Budgie</i> |
|-------|-----------------|------------|---------------|
| Jane | ✗ | ✗ | ✓ |
| Bill | ✓ | ✗ | ✗ |
| Kelly | ✗ | ✓ | ✗ |

Jane : *Budgie*
 Bill : *Goldfish*
 Kelly : *Dog*

2.

| | <i>Badminton</i> | <i>Tennis</i> | <i>Football</i> |
|-------|------------------|---------------|-----------------|
| Karen | ✗ | ✗ | ✓ |
| John | ✗ | ✓ | ✗ |
| Jenny | ✓ | ✗ | ✗ |

Karen : *Football*
 John : *Tennis*
 Jenny : *Badminton*

3.

| | <i>Maths</i> | <i>PE</i> | <i>Art</i> |
|--------|--------------|-----------|------------|
| Daniel | ✓ | ✗ | ✗ |
| Sarah | ✗ | ✓ | ✗ |
| Jane | ✗ | ✗ | ✓ |

Daniel : *Maths*
 Sarah : *PE*
 Jane : *Art*

4.

| | <i>8 yrs</i> | <i>12 yrs</i> | <i>16 yrs</i> |
|---------|--------------|---------------|---------------|
| John | ✓ | ✗ | ✗ |
| Alan | ✗ | ✗ | ✓ |
| Charlie | ✗ | ✓ | ✗ |

John : *8 years*
 Alan : *16 years*
 Charlie : *12 years*

5. Chris : *Baked potato, cheese and beans*
 Adam : *Chips, mushroom pizza and salad*

6.

| | <i>Red</i> | <i>Blue</i> | <i>White</i> | <i>Black</i> |
|--------|------------|-------------|--------------|--------------|
| Amanda | ✗ | ✓ | ✗ | ✗ |
| Jo | ✗ | ✗ | ✗ | ✓ |
| Alex | ✗ | ✗ | ✓ | ✗ |
| Zarah | ✓ | ✗ | ✗ | ✗ |

Amanda : *Blue*
 Jo : *Black*
 Alex : *White*
 Zarah : *Red*

1.1

Answers

7.

| | <i>Bill</i> | <i>John</i> | <i>Fred</i> | <i>Jim</i> |
|-----------|-------------|-------------|-------------|------------|
| Mrs Brown | × | × | ✓ | × |
| Mrs Green | × | ✓ | × | × |
| Mrs Black | ✓ | × | × | × |
| Mrs White | × | × | × | ✓ |

Mrs Brown : *Fred*Mrs Green : *John*Mrs Black : *Bill*Mrs White : *Jim*8. 1st : *Leah*2nd : *Nadida*3rd : *Alice*4th : *Anna*

9.

| | <i>6 years</i> | <i>8 years</i> | <i>11 years</i> | <i>14 years</i> |
|----------|----------------|----------------|-----------------|-----------------|
| Ali | × | ✓ | × | × |
| Mohammed | × | × | × | ✓ |
| Dipak | × | × | ✓ | × |
| Nesima | ✓ | × | × | × |

10. *Question 10 requires pupils to write clues for a given logic table, rather than to solve a problem, given clues.*This is a set of *possible* clues: there are many others.

- Ben kicks a ball into a net
- Abbie does not play a team game
- Helen uses a stick

1.2 Two Way Tables

- (a) 40 (b) 42 (c) 20 (d) 70
(e) Manchester United; more happy fans
- (a) 5 (b) 10 (c) 3 (d) 33
- (a) 74 (b) 179 (c) 60 (d) 288 (e) 534
- (a) 6 (b) 11 (c) BMX (or 12-speed bike)
- (a) $484 - (40 + 36 + 55 + 161 + 144) = 484 - 436$
 $= 48$
(b) 103 (c) 305 (d) 249 boys, 235 girls; more boys

1.2

Answers

6. (a)

| | <i>Less than 4 kg</i> | <i>4 kg or more</i> |
|-------|---------------------------|-------------------------|
| Boys | 64 | 26 |
| Girls | 76 | 14 |

(b) 76

7.

| | <i>Blue Peter</i> | <i>Grange Hill</i> | <i>Newsround</i> |
|--------|-------------------|--------------------|------------------|
| Year 7 | 8 | 13 | 1 |
| Year 8 | 12 | 5 | 5 |

Blue Peter was the most popular programme.

8. (a) 40

(b) You do not know how many had, for example, blue eyes and blond hair.

(c)

| | <i>Blue eyes</i> | <i>Not blue eyes</i> |
|----------------|----------------------|--------------------------|
| Blond hair | 12 | 4 |
| Not blond hair | 6 | 18 |

(d) 18

9. 7 cars are not blue and not hatchbacks.

10. 12 boys played hockey.

Section 1.3 Sets and Venn Diagrams

1. (a)

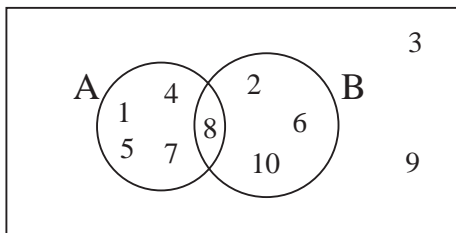

(b) { 8 }

2.

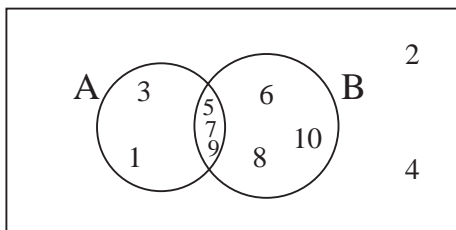

(b) { 1, 3, 5, 6, 7, 8, 9, 10 }

1.3

Answers

3. (a) $A = \{ 2, 4, 6, 8, 10, 12 \}$
 (b) $B = \{ 4, 8, 12 \}$
 (c) $A =$ even numbers up to 12
 $B =$ multiples of 4, $4 \times$ table, up to 12
 (d) $\{ 1, 3, 5, 7, 9, 11 \}$

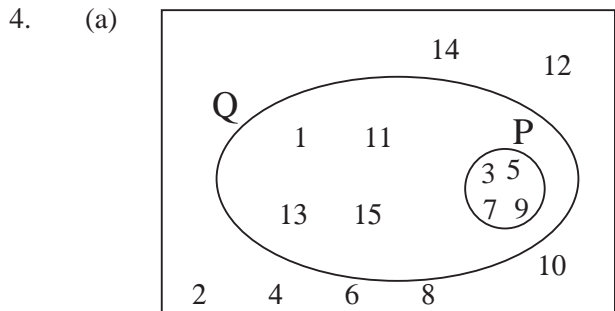

- (b) $\{ 3, 5, 7, 9 \}$

5. (a) $E = \{ 2, 4, 6, 8, 10, 12, 14, 16, 18, 20 \}$
 (b) $S = \{ 1, 4, 9, 16 \}$
 (c) $E =$ even numbers up to 20
 $S =$ square numbers up to 20
 (d) $\{ 1, 2, 4, 6, 8, 9, 10, 12, 14, 16, 18, 20 \}$

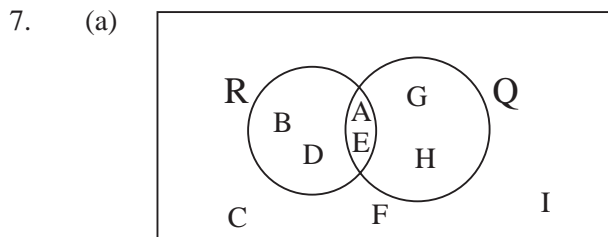
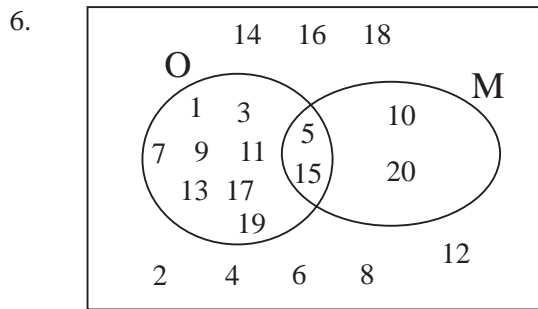

- (b) $\{ A, E \}$ (c) $\{ B, D \}$ (d) $\{ C, F, I \}$

1.3

Answers

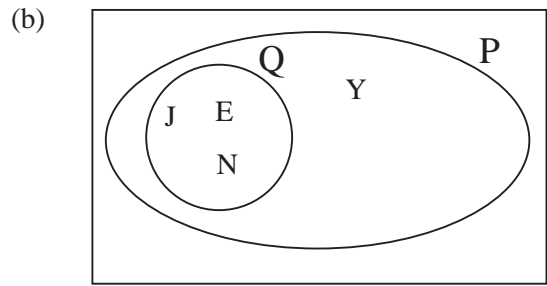
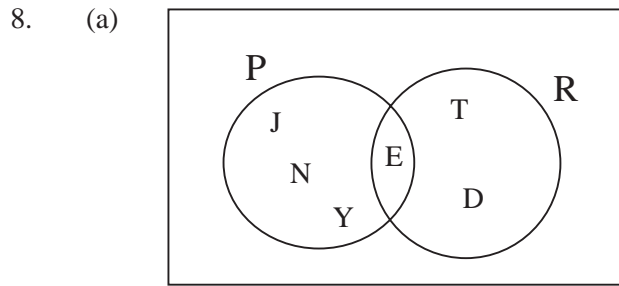

(c) Union = {D, E, J, N, T, Y}

(d) Intersection = {E}

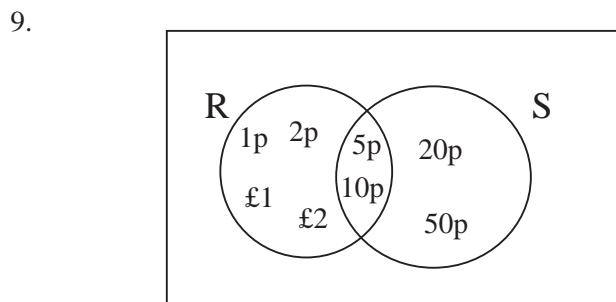

10. (a) C (b) B (c) B (d) A

1.4 Set Notation

1. (a) $A \cap B = \{ 6 \}$
 (b) $A \cup B = \{ 2, 3, 4, 6, 8, 9 \}$
 (c) $A' = \{ 1, 3, 5, 7, 9, 10 \}$
 (d) $B' = \{ 1, 2, 4, 5, 7, 8, 10 \}$
 (e) $A' \cap B' = \{ 1, 5, 7, 10 \}$
 (f) $A' \cup B' = \{ 1, 2, 3, 4, 5, 7, 8, 9, 10 \}$

2. (a) $A \cap B = \{ 21 \}$
 (b) $(A \cap B)' = \{ 10, 11, 12, 13, 14, 15, 16, 17, 18, 19, 20 \}$
 (c) $A \cup B = \{ 12, 14, 15, 18, 21 \}$
 (d) $A' = \{ 10, 11, 12, 13, 15, 16, 17, 18, 19, 20 \}$
 (e) $B' = \{ 10, 11, 13, 14, 16, 17, 19, 20 \}$
 (f) $A' \cap B' = \{ 10, 11, 13, 16, 17, 19, 20 \}$
 (g) $A' \cap B = \{ 12, 15, 18 \}$

1.4

Answers

3. (a) $A \cap B = \{ 1, 10 \}$
 (b) $A \cap C = \{ 3, 6 \}$
 (c) $B \cap C = \emptyset$
 (d) $A \cup B = \{ 1, 3, 5, 6, 10 \}$
 (e) $A \cup C = \{ 1, 3, 6, 9, 10, 12 \}$
 (f) $C' = \{ 1, 2, 4, 5, 7, 8, 10, 11 \}$
 (g) $A \cap C' = \{ 1, 10 \}$
 (h) $B' = \{ 2, 3, 4, 6, 7, 8, 9, 11, 12 \}$
 (i) $B' \cup C' = \{ 1, 2, 3, 4, 5, 6, 7, 8, 9, 10, 11, 12 \}$
 (j) $A \cap B \cap C = \emptyset$
 (k) $A \cup B \cup C = \{ 1, 3, 5, 6, 9, 10, 12 \}$

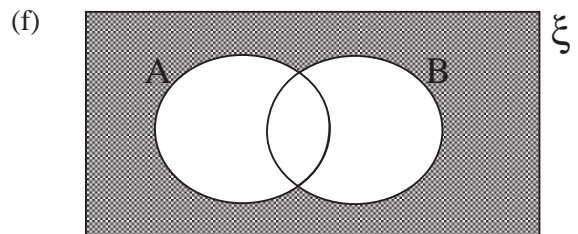
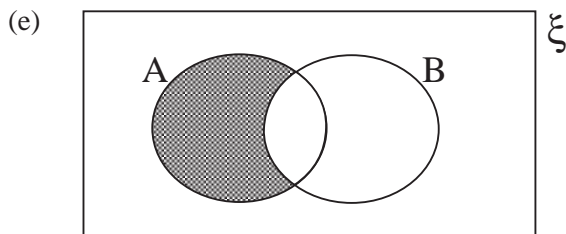
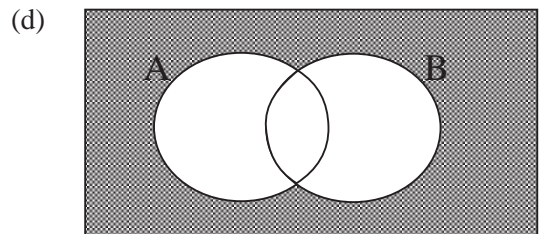
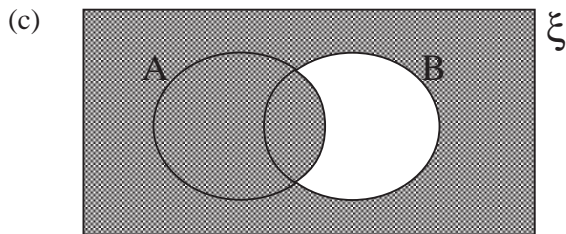
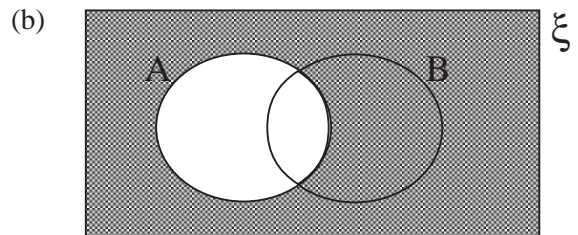
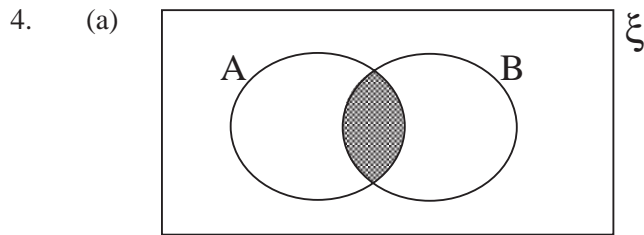

5. (a) $A \cup B$ (b) D' (c) $A \cup B$
 (d) $P \cap Q'$ (e) J (f) $(K \cap L)'$ or $K' \cup L'$
6. (a) True (b) False (c) True
 (d) False (e) True (f) False
 (g) True

1.4

Answers

7. (a) True (b) False $A \subset C$
 (c) True (d) False $A \cap C = \{a, c, e\}$
 (e) True (f) True
 (g) False $A \cap B' = A$

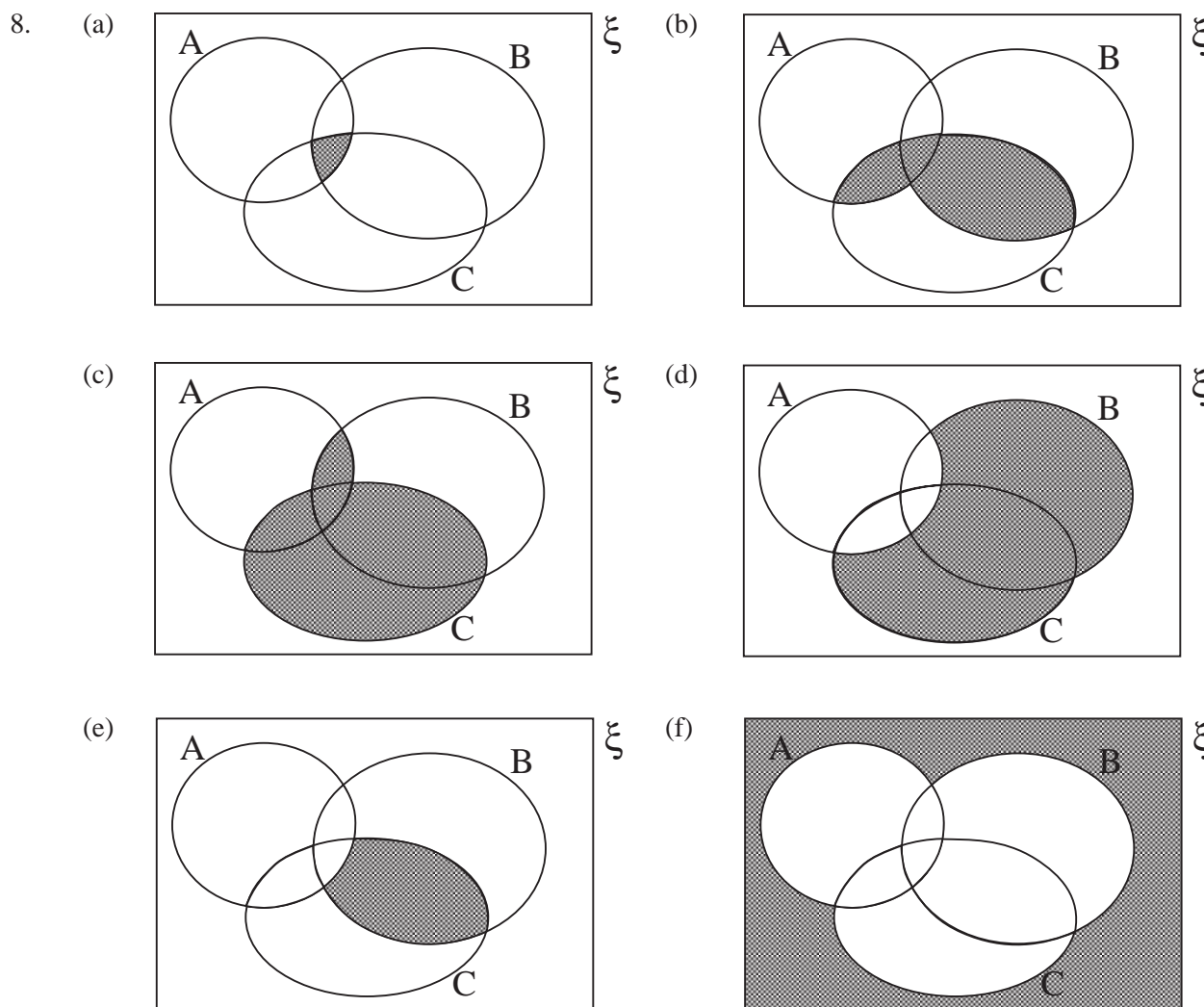

9. (a) $(A \cup B)' \cap C$ (b) $A \cup B \cup C$
 (c) $B \cap A' \cap C'$ (d) $A \cap B$
 (e) $A \cup B \cup C$ (f) $(A \cap C) \cap B'$

1.4

Answers

10.

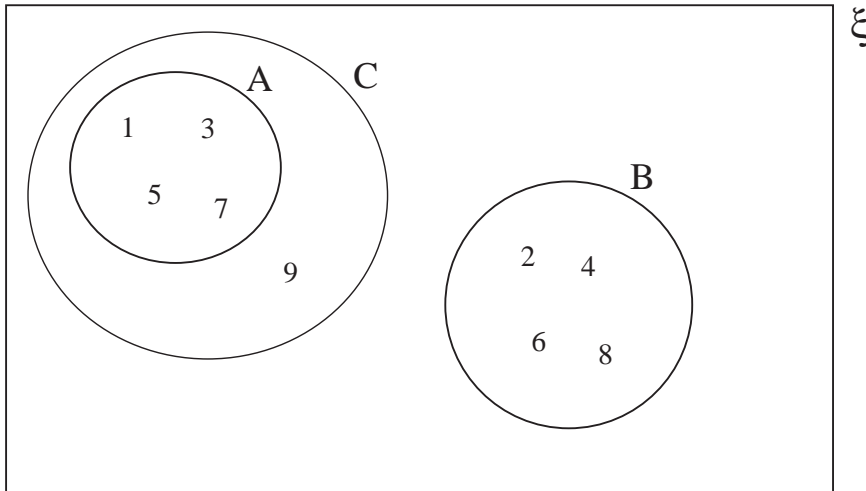

- (a) $A \cap B = \emptyset$
- (b) $C' = \{2, 4, 6, 8\}$
 $= B$
- (c) $A \cap C = \{1, 3, 5, 7\}$
 $= A$
- (d) $B \cap C = \emptyset$
- (e) $A \cup B = \{1, 2, 3, 4, 5, 6, 7, 8\}$
- (f) $(A \cup B)' = \{9\}$
- (g) $(A \cup B) \cap C = \{1, 3, 5, 7\}$
- (h) $(A \cup B) \cap C' = \{2, 4, 6, 8\}$

1.5 Logic Problems and Venn Diagrams

- 1. 1 member of the family plays only football.
- 2. 2 portions of chips have only salt.

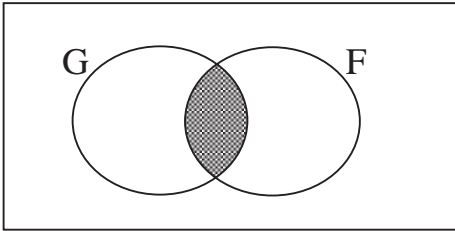
3. (a) 

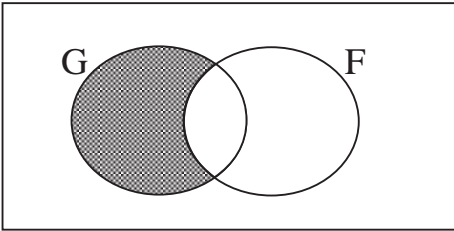
(b) 

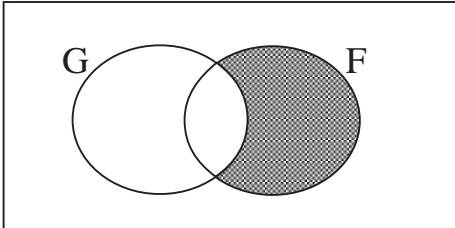
(c) 

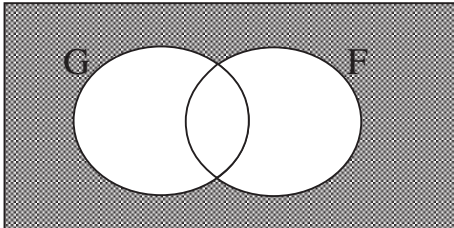
(d) 

- 4. 8 pupils like pancakes and maple syrup.
- 5. (a) 18 cars (b) 12 cars (c) 16 cars

1.5

Answers

- 6. 3 people wear glasses and hold a newspaper.
- 7. 2 blue pens do not work.
- 8. (a) 14 are eating fish and chips.
 (b) 3 are eating fish without chips.
 (c) 12 are eating only chips.

Questions 9, 10 and 11 involve situations that will require Venn diagrams or situations involving 3 sets.

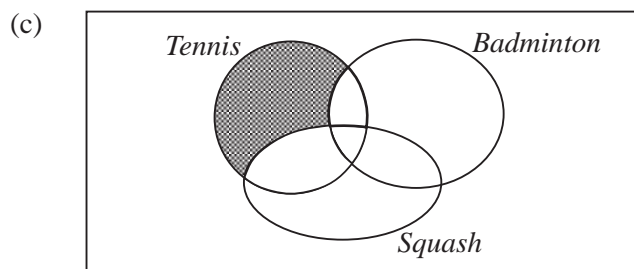
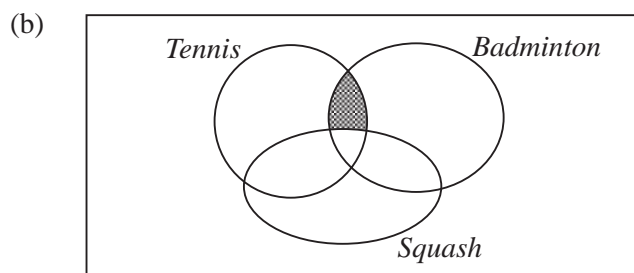
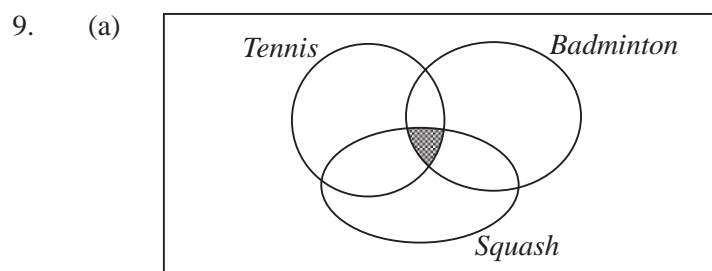

- 10. (a) 10
 (b) Art : 15
 Chess : 19
 Drama : 20
- 11. 17 pupils eat school dinners.

Practice Book *UNIT 2 Arithmetic: Place Value*

Answers

2.1 Place Value and Rounding

1. (a) 90 (b) 50 (c) 70 (d) 10 (e) 10
(f) 0 (g) 4710 (h) 5630 (i) 4760
2. (a) 400 (b) 1400 (c) 24 700 (d) 100 (e) 100
(f) 300
3. (a) 1000 (b) 3 000 (c) 4 000 (d) 132 000 (e) 56 000
(f) 556 000
4. (a) 109 900 (b) 110 000 (c) 109 870 (d) 110 000
5. (a) 1 260 (b) 1 300 (c) 1 000
6. (a) 9 units or 9 (b) 9 tens or 90 (c) 9 tens or 90
(d) 9 hundreds or 900 (e) 9 thousands or 9000 (f) 9 tens or 90
(g) 9 millions or 9 000 000 (h) 9 millions or 9 000 000
(i) 9 hundred millions or 900 000 000
7. (a) Thirty two (b) Fourteen (c) Eighty six
(d) One hundred and twenty four (e) Three hundred and twenty eight
(f) One thousand four hundred and sixty three (g) Three million
(h) Four million, seven hundred and thirteen thousand
(i) Three million, nine hundred and ninety one thousand and one
8. (a) 24 (b) 86 (c) 19 (d) 120 (e) 304
(f) 1 026 (g) 3 400 000 (h) 1 005
9. (a) True (b) False (c) True (d) True (e) False
(f) True (g) False
10. (a) 32, 47, 147, 222, 316, 1 004
(b) 621, 1471, 1472, 3416, 3813, 15 721
(c) 3000, 6000, 30 000, 60 000, 4 000 000
11. (a) 86 432 (b) 23 468 (c) Decreasing ; Increasing
(d) 864 320 (e) 203 468 (if 0 not allowed at the front)

2.1

Answers

12. (a) 7135 (b) 1375
13. 115, 116, 117, 118, 119, 120, 121, 122, 123, 124
14. (a) 42 499 (b) 41 500
15. (a) Liverpool v Crystal Palace (b) 214 000 (c) 21 400

2.2 Decimals and Place Value

1. (a) 5 hundredths or 0.05 (b) 5 tenths or 0.5 (c) 5 units or 5
(d) 5 thousandths or 0.005 (e) 5 hundredths or 0.05 (f) 5 tenths or 0.5
2. 0.5, 0.58, 0.6, 0.8, 0.85, 0.87, 0.9
3. (a) 1.5 (b) 3.7 (c) 0.5 (d) 3.8 (e) 4.1 (f) 5.0
4. (a) 3.44 (b) 8.56 (c) 0.32 (d) 4.76 (e) 0.30
(f) 4.11
5. 4.705, 4.706, 4.707, 4.708, 4.709, 4.710, 4.711, 4.712, 4.713, 4.714
6. (a) 4.6 (b) 5.04 (c) 16.34 (d) 100.05 (e) 1026.005
7. (a) Five and seven tenths (b) Five and six thousandths
(c) Three and two hundredths
8. None: $\frac{4}{10}$ and $\frac{40}{100}$ are the same.
9. 2.4, 1.508, 1.05, 0.7, 0.58, 0.2991
10. (a) 7 430 or 743.0 (b) 0.0347 or 0.347

Practice Book *UNIT 3 Graphs*

Answers

3.1 Scatter Graphs

1. (a) (i) 25 miles (ii) £40 (b) Rory, Halim (c) Prakesh
 (d) Money ÷ distance i.e. £10 ÷ 5 = £2 (e) 40 ÷ 5 = £8 (f) £26
 (g) 23 miles
 (h) Generally yes, but there are exceptions such as Sally and Sunniva
2. (a) (i) 11 years (ii) £4 (b) Ben, Chris (c) Kristian, Chris
 (d) Matthew (e) Chris (f) Matthew (g) Tim
 (h) Rana
 (i) (This question requires pupils to construct an argument using data given in the scatter graph.)
 He could compare himself with children of a similar age like Tim and Chris: £4.
3. (a) Stewart (b) Frederick (c) Alison (d) Robin
 (e) Stewart and Tony (f) Gita (g) Alison, Tony, Stewart
4. (a) Pete (b) Jan (c) Heidi (d) Esther (e) Jan (28)
 (f) Liz and Jai (10)

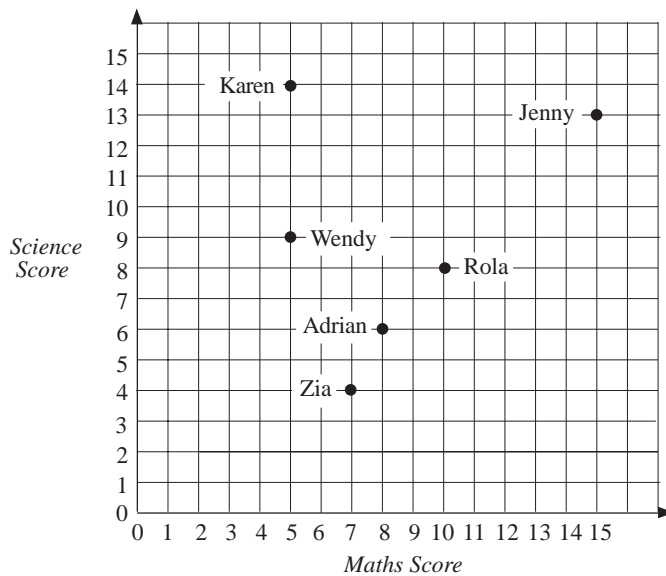

5. (a) Highest: Julie (17 points)
 (b) Second: Jane, Nishi and Veronica (9 points each)

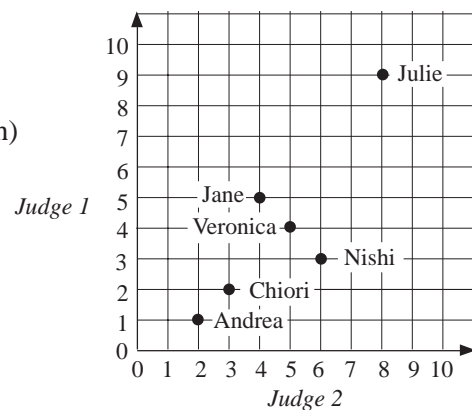

3.1

Answers

6. (a)

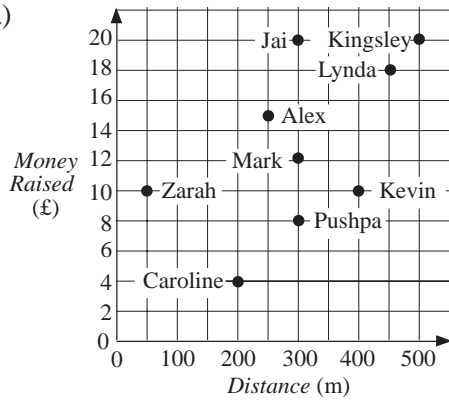

(b) "more"

3.2 Plotting Points

1. A (1, 1), B (4, 8), C (10, 4)

2. (a) (16, 3) (b) (13, 13) (c) (20, 6) (d) (5, 10) (e) (2, 17)
 (f) (15, 17) (g) (10, 18) (h) (5, 4) and (5, 5)

3. (a) and (b)

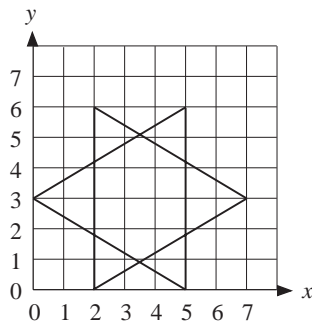

(c) Shape is a star

4. Join these points in order:

(a) (1, 3), (1, 8), (2, 9), (7, 9), (8, 8), (8, 3), (7, 2), (2, 2), (1, 3)

(b) Then join these points to form one dot (4, 5), (4, 6), (5, 6), (4, 5)

Shade the square in the centre.

5.

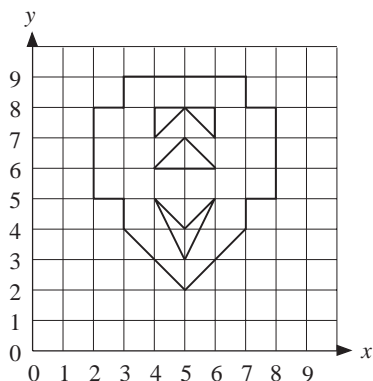

3.2

Answers

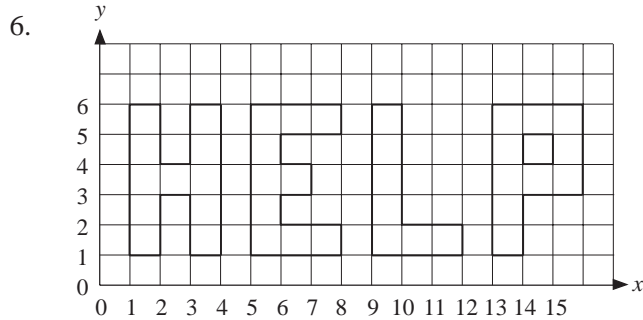

7. (a) For this question you will need a grid like this.

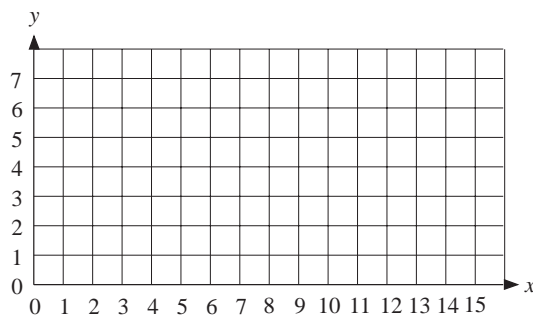

Join each set of points in order, to create the initials of someone's name.

(a) J: (1, 7), (6, 7), (6, 6), (4, 6), (4, 1), (1, 1), (1, 3), (2, 3), (2, 2), (3, 2)
(3, 6), (1, 6), (1, 7)

Dot: (6, 2), (7, 2), (7, 1), (6, 1), (6, 2)

C: (8, 7), (13, 7), (13, 5), (12, 5), (12, 6), (9, 6), (9, 2), (12, 2), (12, 3)
(13, 3), (13, 1), (8, 1), (8, 7)

Dot: (14, 2), (15, 2), (15, 1), (14, 1), (14, 2)

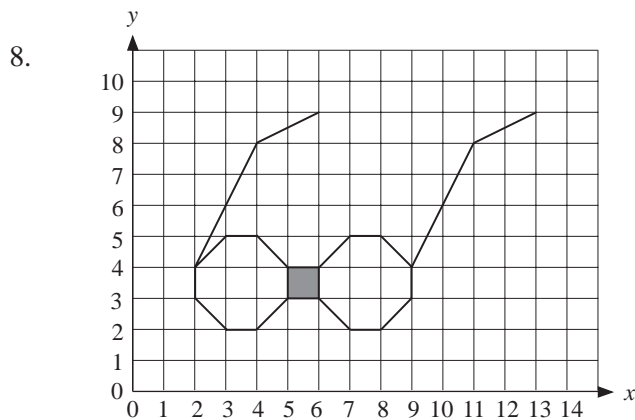

(d) Additional points: (5,4), (4,5), (3,5),
(2,4), (2,3), (3,2), (4,2), (5,3),
and (9,4), (11,8), (13,9)
or (9,4), (7,8), (5,9)

3.3 Negative Numbers

1. (a) 2°C (b) -9°C (c) 0°C (d) 1°C (e) -7°C
(f) -2°C (g) -4°C (h) -4°C (i) -12°C (j) 8°C

Answers

2. (a) 1 (b) -5 (c) -2 (d) -4 (e) -9
 (f) -13 (g) -15 (h) 11 (i) -2 (j) 12
3. (a) -10, -7, -5, -2, 3, 6, 8 (b) -3, -2, -1, 0, 1, 3, 8
 (c) -90, -50, -20, -7, 5, 60, 100
4. (a) $4 > 2$ (b) $-6 < -2$ (c) $-3 < 4$ (d) $2 > -4$
 (e) $-6 > -7$ (f) $-6 < -5$ (g) $0 < 1$ (h) $-1 < 0$
5. (a) False (b) True (c) True (d) True (e) False
 (f) False (g) True (h) True (i) False (j) True
6. (Note that the term *integer* is used in question 6.)
 (a) 6 (b) -4 (c) -4, -5, -6 (d) -5, -4, -3, -2, -1
 (e) 0, 1

3.4 Coordinates

1. (a) (i) (2, 3) (ii) (4, -4) (iii) (-5, -3)
 (iv) (-5, 4) (v) (-3, -1)
 (b) Tennis court; camp site
 (c) He would have to pass through the sea

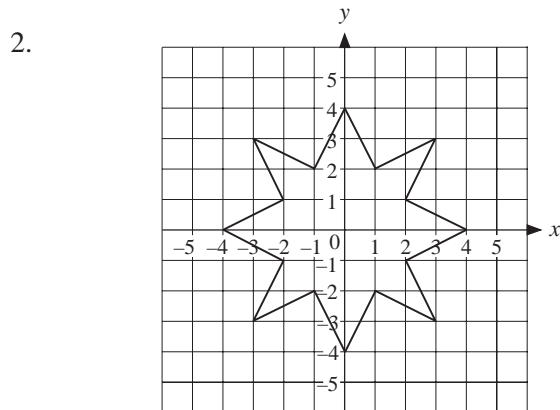

3. (a) (-6, -2), (-6, -4), (-4, -4), (-4, -2)
 (b) Left foot on white square.
 (i) Left on white, right on black
 (ii) Both on white,
 (iii) Left on white, right on black
 (iv) Left on playground, right on black,
 (v) Left on black, right on white

Answers

4.

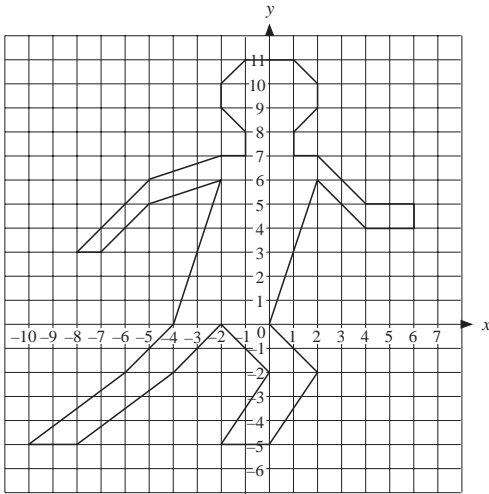

5.

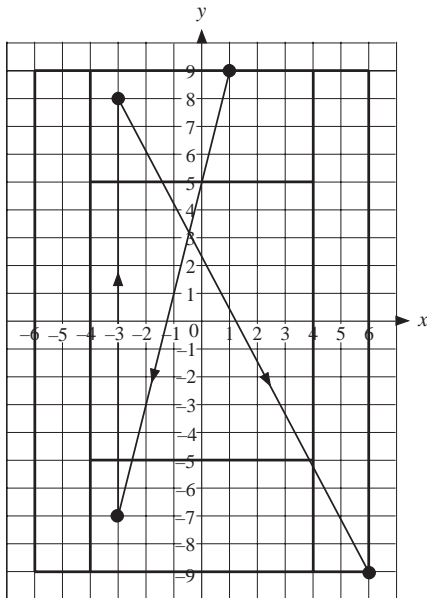

6.

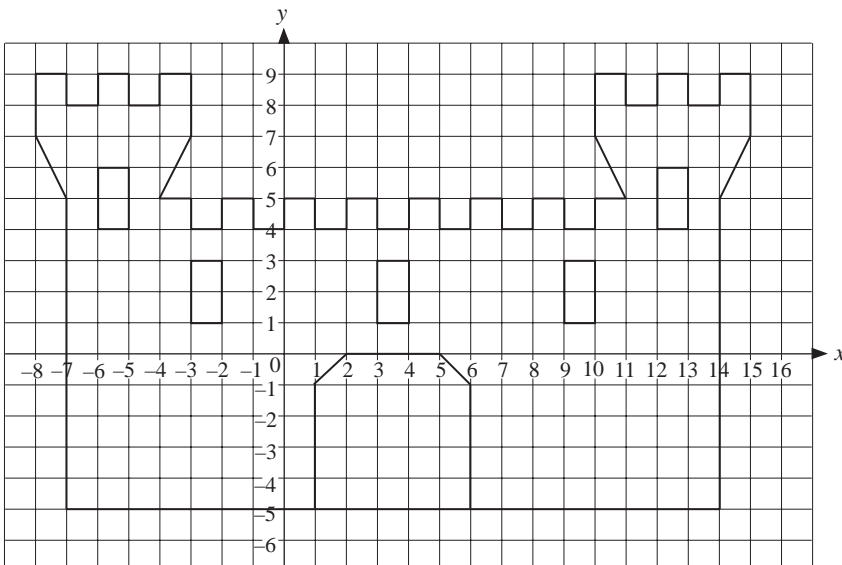

Answers

3.5 Plotting Polygons

1. (a) (2, 3) (b) (5, -6) (c) (-1, 1) (d) (2, -4)
2. (a) (-3, -2) (b) (2, 5) (c) (6, 2) (d) (2, -4) (e) (-4, -5)
3. (a) (5, -5) (b) 5, 0)
4. (a) (6, 2) (b) (6, -4) (c) (-1, 6) (d) (3, -5)
5. (a), (b) (c) Yes it is possible

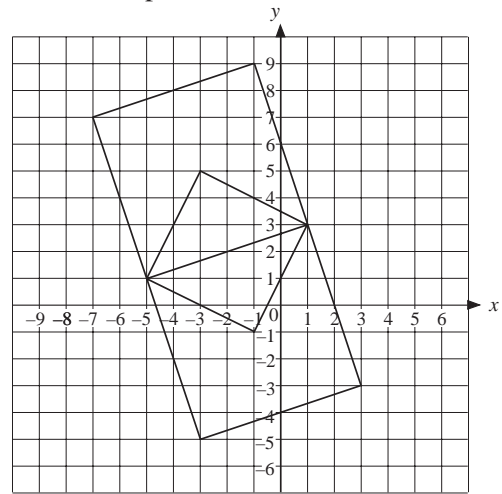
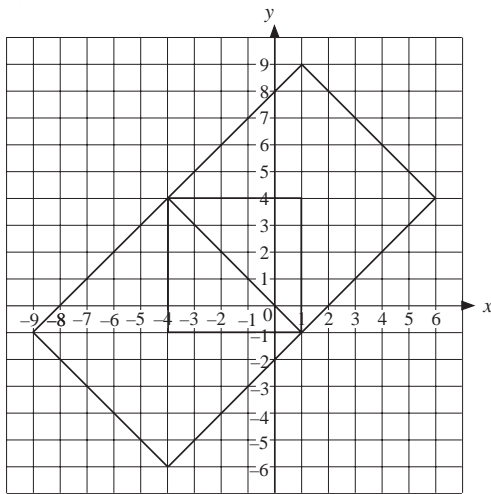

6. (-1, 2)
7. (2, -2), (4, 0)

Note: Pupils may need to be reminded of the meaning of a line of symmetry for the remaining questions.

8. (0, 1) and (-1, -1)

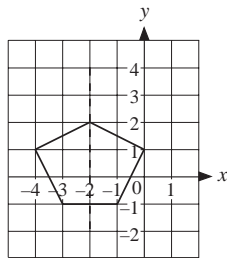

9. (4, -3), (6, -1), (6, 1)
10. (c) (-4, 3), (-2, -5), (6, 0), (5, -3)

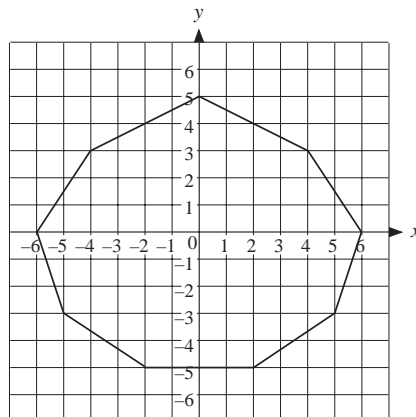

Answers

3.6 Conversion Graphs

1. (a) (i) 30 DK (ii) 70 DK (iii) 45 DK
 (b) (i) £8 (ii) £6 (iii) £2.50
2. (a) (i) 66 lb (ii) 22lb (iii) 99lb
 (b) (i) 50 kg (ii) 9 kg (iii) 38 lb

3. (a), (b)

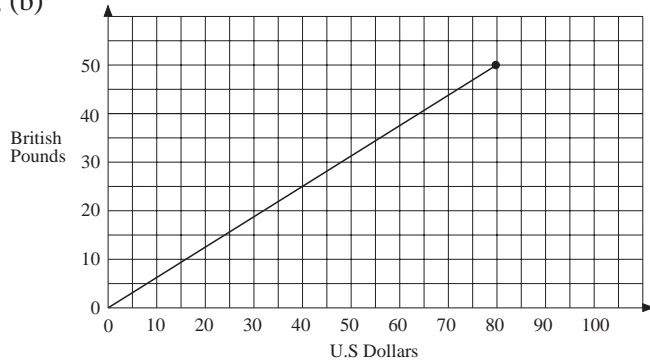

- (c) (i) \$32 (ii) \$56 (iii) \$24
 (d) (i) £31 (ii) £28 (iii) £16

4. (a)

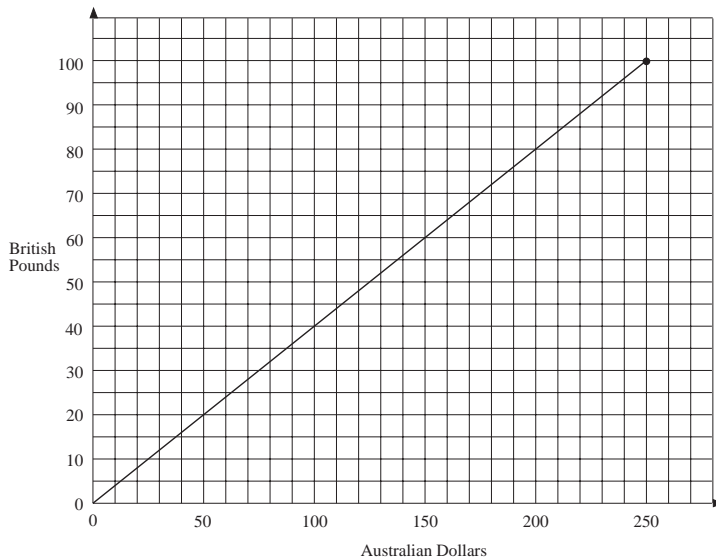

- (b) (i) £80 (ii) £20
 (c) (i) 188 Aus \$ (ii) 200 Aus \$ (iii) 113 Aus \$

5. (a) See over page

- (b) (i) 71°C (ii) 16°C (iii) 21°C (iv) 35°C
 (c) (i) 140°F (ii) 68°F (iii) 86°F (iv) 113°F
 (d) See where the line crosses the vertical axis.
 (e) $-40^{\circ}\text{C} = -40^{\circ}\text{F}$

Answers

5. (a)

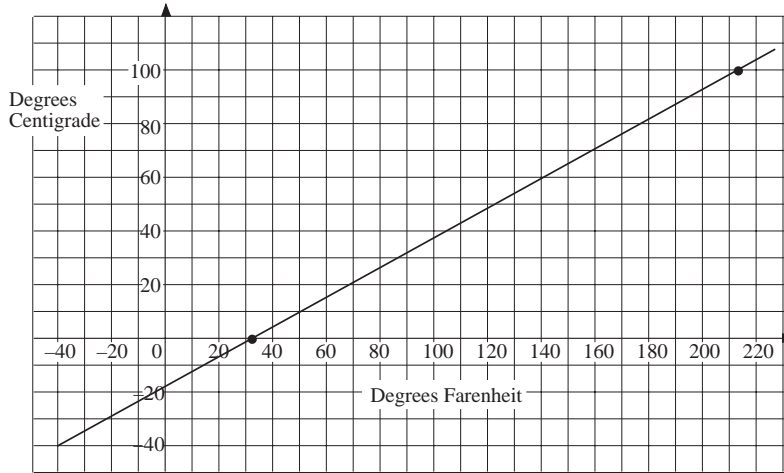

6. (a) 120 minutes (b) 25 minutes (c) 1400 grams (d) 65 minutes

7. (a)

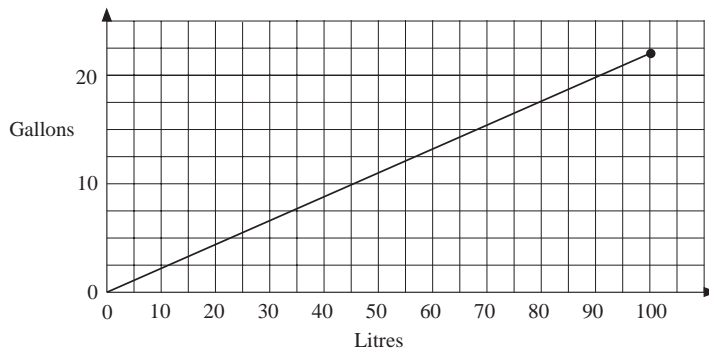

(b) 91 litres (c) 9 gallons (d) 36 litres (e) 9 gallons
 (f) 68 litres (g) 36 cans (h) Old toilet uses about 1 litre more than the new toilet.

8.

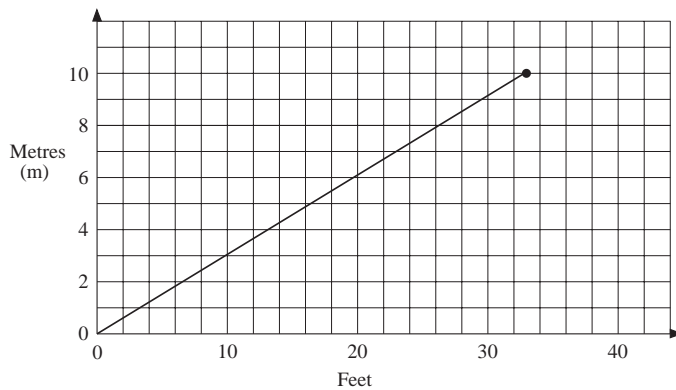

(a) Mohammed by about 1 foot (b) 6.5 m
 (c) Yes, 8 m is about 26.5 feet (d) 30 feet (e) 6.5 m or 21 feet.

Practice Book *UNIT 4 Arithmetic: Addition and
Subtraction of Decimals*

Answers

4.1 Addition and Subtraction

1. (a) 8 (b) 11 (c) 16 (d) 15 (e) 13 (f) 14
(g) 36 (h) 27 (i) 31 (j) 43 (k) 25 (l) 45
(m) 56 (n) 88 (o) 89
2. (a) True (b) False (c) True (d) True
(e) True (f) False (g) False (h) True
3. (a) 3 (b) 2 (c) 3 (d) 2 (e) 12 (f) 13 (g) 13 (h) 22
(i) 3 (j) 9 (k) 9 (l) 8 (m) 36 (n) 45 (o) 18
4. (a) 7 (b) 4 (c) 1 (d) 9 (e) 12 (f) 21 (g) 9
(h) 75 (i) 12 (j) 10
5. (a) $5 - (8 - 7) = 4$ (b) $6 - (3 + 2) = 1$
(c) $5 + 7 - (2 - 1) = 11$ (d) $14 - (7 - 3) - 2 = 8$
6. (a) 33 (b) 40 (c) 137 (d) 166
7. (a) 3 (b) 25 (c) 46 (d) 27
8. (a) 60 (b) 4
9. (a) 29 (b) 6
10. (a) 30 (b) 6
11. 47
12. 88
13. (a) 58 (b) 124 (c) 318
14. 225
15. £142
16. 398 miles
17. (a) 37 (b) 139 (c) 127 (d) 49 (e) 53 (f) 100 (g) 121
(h) 16 (i) 63 (j) 28 (k) 77 (l) 88 (m) 43 (n) 98

4.1

Answers

18 (a) 0.9 (b) 0.9 (c) 0.53 (d) 4.9 (e) 4.88 (f) 8.1 (g) 10.3
(h) 14.11 (i) 17.62 (j) 8.81 (k) 1.561 (l) 11.02 (m) 21.34 (n) 19.718

19. (a) 0.5 (b) 0.3 (c) 1.2 (d) 1.1 (e) 3.4 (f) 1.6 (g) 1.9
(h) 1.8 (i) 10.94 (j) 16.92 (k) 11.74 (l) 8.28 (m) 0.66 (n) 0.39

4.2 Dealing with Money

1. (a) (i) 75p (ii) 57p (iii) £1.40
(b) A can of drink and a packet of crisps.

2. 14p

3. £2.65

4. £16.99

5. £5.14

6. £7.20

7. (a) £17.16 (b) £2.84

8. (a) £1.96 (b) £3.13 (c) 41p

9. 12.46 kg

Note that questions 10 and 11 contain mixed units. Students will need to be able to convert from metres to centimetres or vice versa.

10. (a) 151 cm or 1.51 m (b) 49 cm or 0.49 m

11. 16 cm or 0.16 m

12. £11.13

Practice Book *UNIT 5 Angles*

Answers

5.1 Angles and Turns

1. (a) (i) W (ii) S (iii) NE (iv) E (v) SE
 (b) (i) 90° (ii) 45° (iii) 90° (iv) 225° (v) 315°
 (c) (i) 270° (ii) 315° (iii) 270° (iv) 135° (v) 45°
2. (a) 360° (b) 720° (c) 270° (d) 450° (e) 630° (f) 810°
3. (a) 90° (b) 45° (c) 180° (d) 315° (e) 135° (f) 45°
 (g) 315° (h) 90° (i) 135°
4. (a) 135° (b) 315° (c) 315° (d) 270°
5. (a) SW (b) NW (c) NW (d) NE (e) E (f) SW (g) S
6. (a) Radio Mast (b) Old Fort (c) 90° clockwise or 270° anticlockwise
 (d) (i) 315° (ii) 45° (iii) 135°
 (e) (i) Old Fort (ii) Church Tower (iii) Ship (iv) Radio Mast
7. (a) Church (b) Big Rock (c) Windmill (d) Windmill (e) Lighthouse
 (f) N (g) NW (h) No, the tower is not exactly in a direction SE of the windmill.
8. (a) Great Yarmouth (b) Aylsham (c) Beccles (d) Aylsham
 (e) Holt (f) Beccles
9. (a) (i) 20 s (ii) 10 s (iii) 5 s
 (b) (i) 270° (ii) 135° (iii) 225°

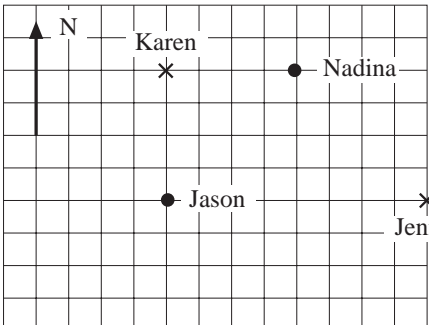
10. (a) 

- (d) Wendy is S of Nadina.
 (e) Anywhere on straight line joining Karen's position to Jason's.

Answers

5.2 Measuring Angles

1. (a) 50° (b) 60° (c) 80° (d) 145°
 (e) 95° (f) 45° (g) 105° (h) 38°
2. (a) 235° (b) 290° (c) 231° (d) 338°
3. (a) Manchester United 160° , Arsenal 40° ,
 Newcastle 50° , Chelsea 75° ,
 Other 35°
 (b) Largest sector (largest angle) (c) Chelsea
5. (a) $\hat{ADC} = 118^\circ$; $\hat{BAE} = \hat{BCD} = 84^\circ$; $\hat{AED} = \hat{CDE} = 127^\circ$
 (b) $\hat{DAF} = \hat{CDE} = 127^\circ$; $\hat{ADC} = \hat{BCD} = \hat{DEF} = \hat{AFE} = 117^\circ$
 (c) All angles = 135°
 (d) $\hat{ABC} = 127^\circ$; $\hat{DAG} = \hat{BCD} = 117^\circ$; $\hat{AGF} = \hat{CDE} = \hat{GFE} = \hat{DEF} = 135^\circ$
6. (b) $AB = 8.7 \text{ cm}$, $AB = 9.2 \text{ cm}$, $AC = 11.9 \text{ cm}$

7.

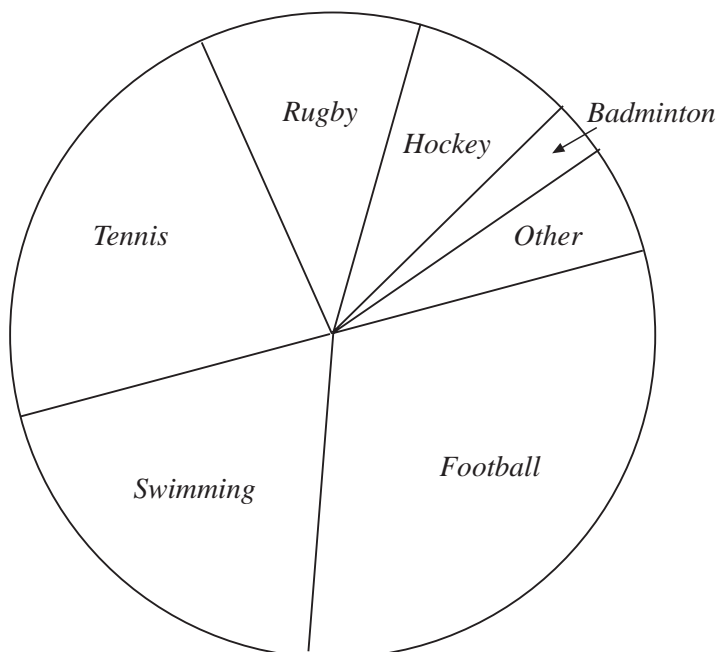

Answers

5.3 Classifying Angles

- Reflex
 - Acute
 - Obtuse
 - Reflex
 - Acute
 - Obtuse
- A : acute; B : obtuse; C : acute; D : reflex
 - A : acute; B : obtuse; C : obtuse; D : acute; E : acute; F : reflex

- For example: 

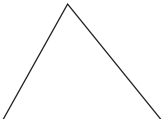
- For example: 

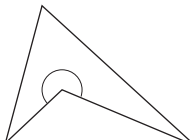
- For example: 

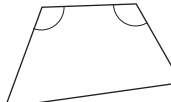
- For example: 

5.4 Angles on a Line and Angles at a Point

- 110°
 - 95°
 - 40°
 - 13°
 - 32°
 - 46°
- 82°
 - 144°
 - 75°
 - 150°
 - 241°
 - 80°
- 125°
- $a = 110^\circ$, $b = 100^\circ$
 - Increases to 105°
- 72°
 - 40°
- 109°
- $a = 152^\circ$, $b = 28^\circ$, $c = 152^\circ$
Opposite angles are equal.
- 36° and 144°
- $a = 27^\circ$, $b = 152^\circ$
- 60°
 - 36°
 - 12 sides

Answers

5.5 Constructing Triangles

- $30^\circ + 61^\circ + 89^\circ = 180^\circ$
 - $34^\circ + 102^\circ + 44^\circ = 180^\circ$
 - $30^\circ + 50^\circ + 100^\circ = 180^\circ$
 - $120^\circ + 30^\circ + 30^\circ = 180^\circ$
- Comparison of pupils' work
- The lengths of the two shorter sides do not add up to or exceed the length of the longest side.

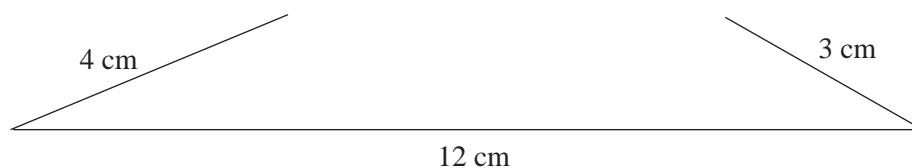

- Triangles (a), (b) and (d) can be drawn.
 - $59^\circ, 35^\circ, 86^\circ$
 - $32^\circ, 95^\circ, 53^\circ$
 - $60^\circ, 60^\circ, 60^\circ$
- $AB = 6.2$ cm, $BC = 5.1$ cm
 - $\angle ABC = 90^\circ$
- 60°
 - 130°
 - 40°
 - 40°

The sum of the interior angles of a triangle is 180° .

5.6 Finding Angles in Triangles

- 50°
 - 25°
 - 63°
 - 37°
 - 125°
 - 48°
- $a = b = 50^\circ$
 - $a = 85^\circ, b = 10^\circ$
 - $a = b = c = 60^\circ$
 - $a = b = 29^\circ$
- Isosceles
 - Scalene
 - Isosceles
 - Equilateral
- $a = 55^\circ, b = 125^\circ$
 - $a = 48^\circ, b = 132^\circ$
 - $a = 34^\circ, b = 146^\circ$
 - $a = 42^\circ, b = 138^\circ$
- Exterior angle = sum of two interior opposite angles.
 - 102°
 - 142°
 - 137°
 - 133°
- $a = 119^\circ, b = 126^\circ, c = 115^\circ$
 Yes, $a + b + c = 360^\circ$.

5.6

Answers

7. (a) $115^\circ + 115^\circ + 130^\circ = 360^\circ$ (b) $150^\circ + 160^\circ + 50^\circ = 360^\circ$
 (c) $90^\circ + 142^\circ + 128^\circ = 360^\circ$ (d) $122^\circ + 118^\circ + 120^\circ = 360^\circ$

Exterior angles add up to 360° .

8. (a) $a = 69^\circ$ (b) $a = 41^\circ$ (c) $a = b = 90^\circ$
 (d) $a = 50^\circ$, $b = 65^\circ$, $c = 65^\circ$, $d = 115^\circ$ (e) $a = b = c = 120^\circ$
 (f) $a = b = 70^\circ$, $c = 40^\circ$, $d = 110^\circ$

9.

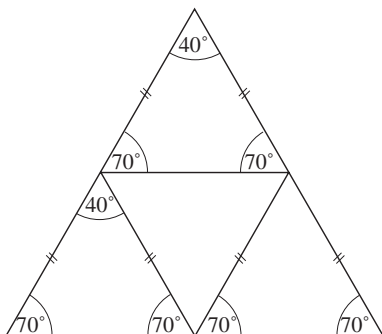

10. (a) interior angles are each 85° (b) each 80° ; each 75°
 (c) Other angles decrease another 5° to 70° .
11. 70° , 55° , 55° or 70° , 70° , 40°

Practice Book *UNIT 6 Arithmetic:*
Multiplication of Decimals

Answers

6.1 Multiplication of Whole Numbers

- (a) 6 (b) 35 (c) 18 (d) 21 (e) 20 (f) 18 (g) 40
(h) 36 (i) 36 (j) 56 (k) 72 (l) 63 (m) 42 (n) 81
(o) 48
- (a) True (b) False (c) False (d) True
- (a) £20 (b) 6 months
- 18 bottles
- £12
- 42 tiles
- 72 packets
- 24 cars
- 25 cars
- 63 windows

6.2 Long Multiplication

- (a) 126 (b) 280 (c) 132 (d) 387 (e) 744 (f) 480 (g) 1848 (h) 912
(i) 1116 (j) 2666 (k) 7224 (l) 35 958 (m) 35 328 (n) 161 504 (o) 35 568
- (a) 1554 (b) 5022 (c) 1302 (d) 1161 (e) 2378
(f) 1748 (g) 2109 (h) 1421 (i) 924
- (a) 180 (b) 672 (c) 3738 (d) 2565 (e) 5642 (f) 47 936

Answers

6.3 Multiplying with Decimals

- (a) 2.4 (b) 3.5 (c) 7.8 (d) 10.8 (e) 9.0 (f) 63.2
(g) 6.72 (h) 40.32 (i) 17.64 (j) 16.56 (k) 7.44
(l) 109.5 (m) 206.8 (n) 440.2 (o) 392.2
- (a) 60 (b) 7 (c) 1 220 (d) 1 120 (e) 32 (f) 6 200
(g) 1470 (h) 184.1 (i) 36 500 (j) 7 200 000
- (a) 3.952 (b) 36.075 (c) 21.1698
(d) 37.3584 (e) 123.971 (f) 15.087

6.4 Problems Involving Multiplication

- £252
- 192 bars
- 416 seats
- 768 bottles
- £1120
- 216 slabs
- £12.90
- £15.24
- £18.98
- £12.80
- £39.92
- £7.81 to the nearest penny
- £2.54 to the nearest penny
- $365 \times 260 = 94\,900$ (ordinary year)
 $366 \times 260 = 95\,160$ (leap year)
 $5 \times 52 \times 260 = 67\,600$ (5 days a week, 52 weeks per year)
Other variations are possible



Practice Book *UNIT 7 Number Patterns and Sequences*

Answers

7.1 Multiples

1. (a) 24 (b) 60 (c) 72 (d) 600
2. Multiples of 11;
 - (a) The 3rd multiple of 11 is 33 (b) The 9th multiple of 11 is 99
 - (c) The 200th multiple of 11 is 2200 (d) The 6th multiple of 11 is 66
 - (e) The 30th multiple of 11 is 330
3. (a) 8, 16, 24, 32, 40, 48, 56, 64
 (b) 6, 12, 18, 24, 30, 36, 42, 48
 (c) 24 (d) 48, 72
4. (a) 12, 24, 36, 48, 60, 72 (b) 120 (c) 1200
 (d) 6000 (e) $n = 4$ (f) $n = 8$
5. (a) Multiples of 9 (b) 108
6. (a) Because $12 = 2 \times 6$ and $12 = 3 \times 4$ (b) Yes: 1, 2, 3, and 12
7. 1, 4, 6, 8, 12 and 24
8. 2
9. (a) 13 (b) 247
10. 17
11. 19
12. 7

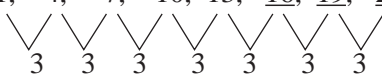
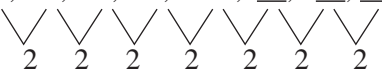
7.2 Finding the Next Term

1. (a) 1, 4, 7, 10, 13, 16, 19, 22, ...

- (b) 3, 5, 7, 9, 11, 13, 15, 17, ...

- (c) 5, 8, 11, 14, 17, 20, 23, 26, ...

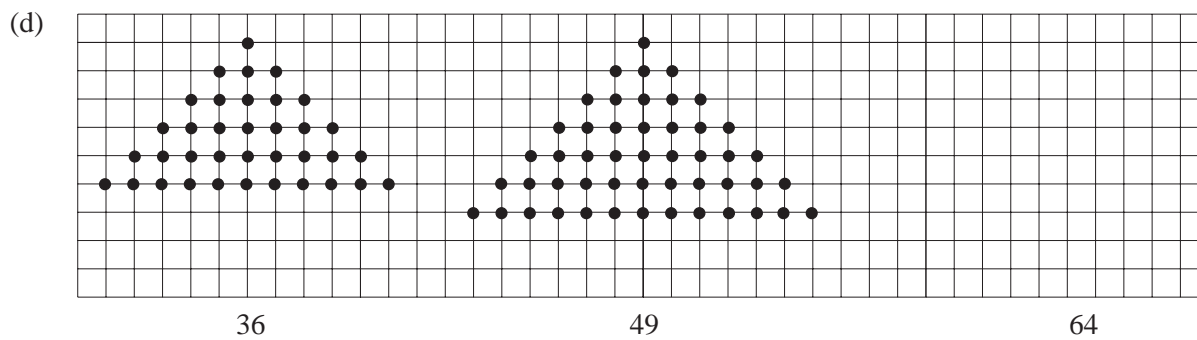
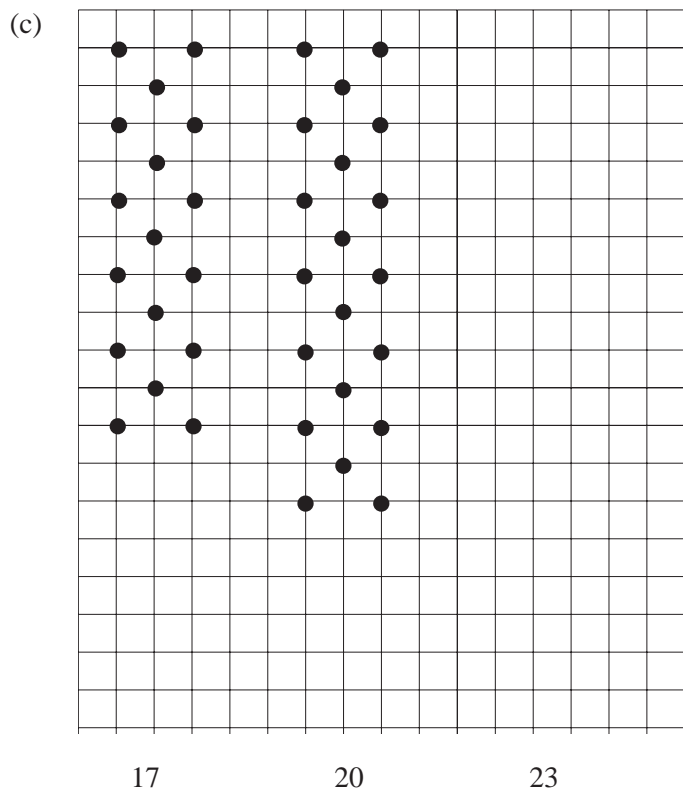
7.2

Answers



5. (a) 1 (b) 5 (c) 7 (d) 10 (e) 15
6. (a) 1, 4, 9, 16, 25, 36, 49, 64, ...
 (b) 2, 5, 10, 17, 26, 37, 50, 65, ...
 (c) 0, 3, 7, 12, 18, 25, 33, 42, ...
 (d) 6, 12, 20, 30, 42, 56, 72, 90, ...
 (e) 0.5, 2.0, 4.5, 8.0, 12.5, 18.0, 24.5, 32.0, ...

7.2

Answers

7. (a) 2, 4, 8, 16, 32, ...
 (b) 100, 81, 64, 49, 36, ...
 (c) 6, 9, 14, 21, 30, ...
 (d) 0, 1.5, 4, 7.5, 12, ...
 (e) 1, 7, 17, 31, 49, ...

In question 8 pupils should consider whether the numerators and denominators form a sequence.

8. (a) $\frac{5}{6}$, $\frac{6}{7}$ (b) $\frac{5}{15}$, $\frac{4}{16}$ (c) $\frac{11}{10}$, $\frac{13}{11}$ (d) $\frac{6}{25}$, $\frac{7}{36}$ (e) $\frac{24}{26}$, $\frac{35}{37}$

7.3 Generating Number Sequences

1. (a) 9 (b) 3 (c) 23 (d) 21 (e) 30 (f) 15
 2. (a) 5 (b) 6 (c) 12 (d) 5 (e) 2 (f) 9
 3. (a) 2, 3, 4, 5, 6, ... (b) 2, 4, 6, 8, 10, ... (c) 3, 4, 5, 6, 7, ...

The machine in (b) gives even numbers.

4. (a) 2, 4, 6, 8, 10 (b) 4, 6, 8, 10, 12
 5. (a) Add 10 (b) Multiply by 10 (c) Multiply by 7 (d) Add 1.5
 6. (a) 3, 6, 9, 12, 15 (b) 4, 7, 10, 13, 16 (c) 7, 10, 13, 16, 19
 (d) 2, 5, 8, 11, 14 (e) 1, 4, 7, 10, 13
 7. (a) 9, 18, 27, 36, 45 (b) 12, 24, 36, 48, 60 (c) 3, 5, 7, 9, 11
 (d) 5, 8, 11, 14, 17 (e) 3, 8, 13, 18, 23 (f) 6, 13, 20, 27, 34
 8. (a) 21 (b) 30 (c) 21 (d) 34
 9. (a) 8, 9, 10, 11, 12, 13
 (b) (i) 6, 7, 8, 9, 10; $n + 5$ (ii) 0, 1, 2, 3, 4; $n - 1$
 (iii) 3, 4, 5, 6, 7; $n + 2$

10. (a) 4, 8, 12, 16, 20, ...

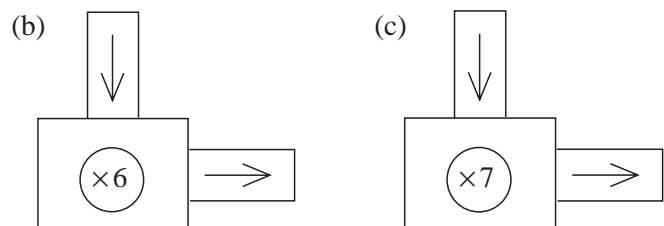

7.3

Answers

11. (a) 3, 5, 7, 9, 11, ... ; $2n + 1$
 (b) (i) 1, 3, 5, 7, 9, ... ; $2n - 1$
 (ii) 7, 11, 15, 19, 23, ... ; $4n + 3$
 (iii) 3, 8, 13, 18, 23, ... ; $5n - 2$
 (iv) 3, 4, 5, 6, 7, ... ; $n + 3 - 1 = n + 2$
 (c) $n + 3 - 1 = n + 2$

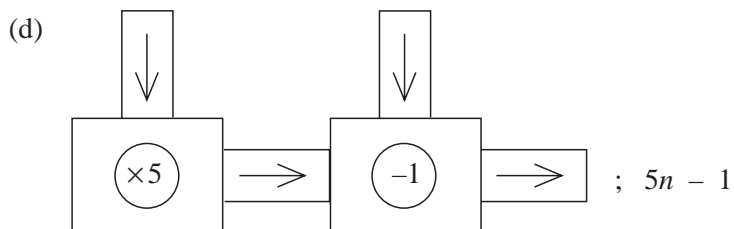
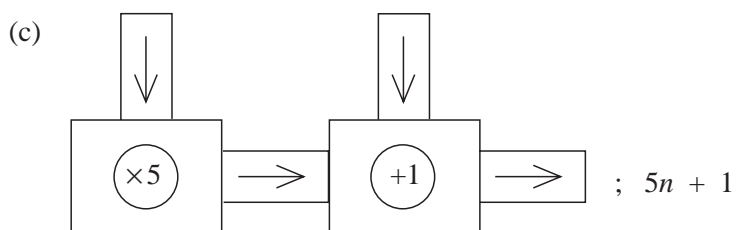
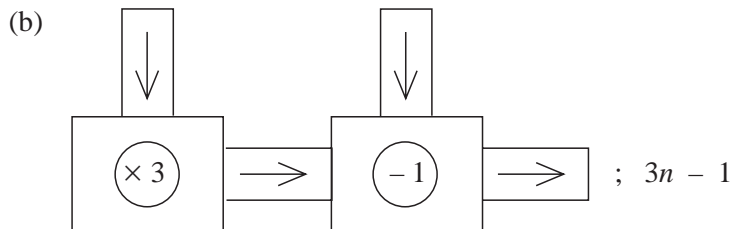
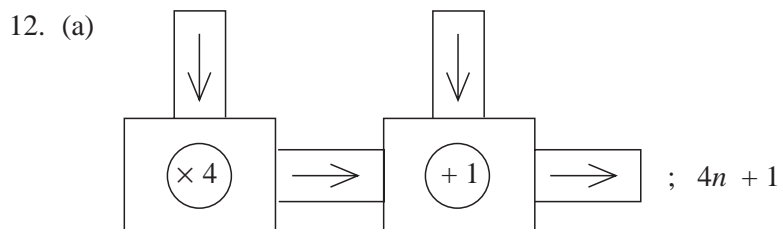
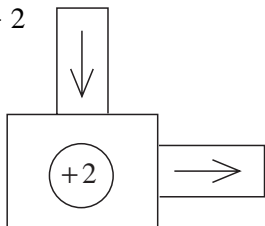

7.3

Answers

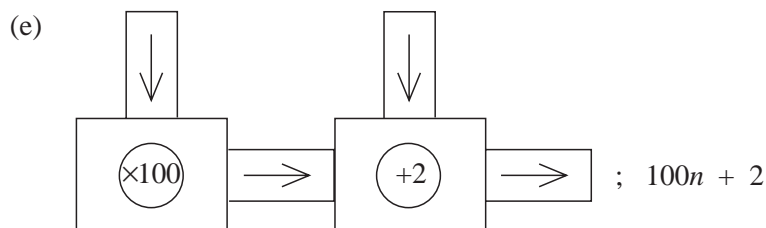

7.4 Formulae for General Terms

- 3
 - $2 = 3 \times 1 - 1$
 $5 = 3 \times 2 - 1$
 $8 = 3 \times 3 - 1$, etc.
- 2
- $6 = 2 \times 1 + 4$
 $8 = 2 \times 2 + 4$, etc.
- (a) 2; $2n + 1$ (b) 6; $6n - 1$ (c) 3; $3n + 1$
(d) 3; $3n - 1$ (e) 4; $4n + 2$
- (a) $4n$ (b) $5n$
- (a) $7n$ (b) Add 1 to each term (c) $7n + 1$
- (a) 11, 22, 33, 44, 55, 66, ... (b) $11n$ (c) $11n - 1$
- (a) $3n$ (b) $7n - 2$ (c) $8n + 13$ (d) $3n + 5$ (e) $3n - 2$ (f) $3n + 100$
- (a) Numerator is always 1; denominator is multiple of 2, i.e. $2n$ (b) $\frac{1}{2n + 1}$
- (a) $\frac{n}{n + 1}$ (b) $\frac{n}{n + 3}$ (c) $\frac{n}{n + 9}$ (d) $\frac{2n}{n + 7}$ (e) $\frac{3n}{n + 4}$
- (a) $n^2 - 1$ (b) $n^2 + 9$ (c) $2n^2$ (d) n^3

Practice Book *UNIT 8 Division of Decimals***Answers**

8.1 Mental Division of Whole Numbers

- (a) 4 (b) 2 (c) 3 (d) 5 (e) 2 (f) 5 (g) 4 (h) 5
(i) 8 (j) 6 (k) 4 (l) 4 (m) 7 (n) 7 (o) 9
- (a) False (b) False (c) True (d) True
- (a) 35 (b) 26 (c) 44 (d) 11 (e) 1 (f) 15
(g) 8 (h) 13 (i) 9 (j) 8 (k) 31 (l) 39
- (a) 125 (b) 13 (c) 17 (d) 32 (e) 56
(f) 13 (g) 5 (h) 7 (i) 16

8.2 Division Methods for Whole Numbers and Decimals

- (a) 1.2 (b) 420 (c) 60 000 (d) 371.4 (e) 572.8 (f) 60
(g) 7 (h) 750 (i) 7.5 (j) 37.14 (k) 84.12 (l) 64.213
- (a) 23 (b) 505 (c) 2204 (d) 421 (e) 1234 (f) 7410
(g) 184 (h) 562 (i) 56 (j) 234 (k) 238 (l) 256
- (a) 1.27 (b) 7.21 (c) 2.56 (d) 17.5 (e) 131.2 (f) 12.31
(g) 25.9 (h) 10.32 (i) 119.14
- (a) 5.25 (b) 40.5 (c) 40.5 (d) 65.75 (e) 10.5 (f) 30.125

8.3 Division Problems

- 9 bars
- 31 cars
- 48 passengers
- £ 5
- £ 125.23
- £ 9.25
- 6 sweets
- £ 5

8.3**Answers**

9. £9

10. 5.62 m

11. 162 g

12. £1.37 with 2p left over

13. 4 minibuses

14. 8 bars

15. 5 times

16. (a) 6 lumps (b) 30 g

17. (a) 5 tapes (b) 75p

18. 19 books

Practice Book *UNIT 9 Areas and Perimeters*Answers

9.1 Area

2. about 38 squares
3. (a) 11 squares (b) 10 squares (c) 8 squares (d) 24 squares

9.2 Area and Perimeter of a Square

1. (a) Area: 4 cm^2 , Perimeter: 8 cm (b) Area: 25 cm^2 , Perimeter: 20 cm
(c) Area: 25 cm^2 , Perimeter: 20 cm (d) Area: 49 cm^2 , Perimeter: 28 cm
2. (a) 100 cm^2 (b) 144 cm^2 (c) 64 cm^2
(d) 81 cm^2 (e) 225 cm^2 (f) 400 cm^2
3. (a) 52 cm (b) 32 cm (c) 64 cm (d) 76 cm (e) 36 cm (f) 72 cm
4. (a) 32 mm (b) 103 mm (c) 2.8 cm (d) 21.6 cm (e) 1.52 m
(f) 0.84 m (g) 162 cm (h) 170 cm (i) 82 cm (j) 7 cm
5. (a) 400 mm^2 (b) 4 cm^2
6. 10 cm
7. 6 cm
8. 121 cm^2
9. 48 cm
10. (a) 4 cm (b) 8 cm

9.3 The Area and Perimeter of a Rectangle

1. 8 cm^2 (b) 18 cm^2 (c) 30 cm^2 (d) 6 cm^2
2. 12 cm (b) 18 cm (c) 22 cm (d) 14 cm
3. (a) 24 cm^2 (b) 8 cm^2 (c) 36 cm^2
(d) 11 mm^2 (e) 42 m^2 (f) 27 mm^2
4. (a) 22 cm (b) 12 cm (c) 26 cm (d) 24 mm (e) 26 cm (f) 24 mm

9.3

Answers

| 5. | <i>Area</i> | <i>Perimeter</i> |
|-----|-----------------------|------------------|
| (a) | 24.8 cm ² | 20.4 cm |
| (b) | 13.5 cm ² | 15 cm |
| (c) | 22.68 mm ² | 19.2 mm |
| (d) | 2.1 m ² | 5.8 m |
| (e) | 21.96 cm ² | 19.4 cm |
| (f) | 59.2 mm ² | 30.8 mm |

6. (a) Area: 0.3 m² or 3000 cm²
 (b) Perimeter: 2.6 m or 260 cm

7. 15 cm² or 1500 mm²

8. Perimeter = 4.6 mm or 0.46 cm
 Area = 120 mm² or 1.2 cm²

9. 28 cm

10. 4 cm and 8 cm

9.4 Area of Compound Shapes

1. (a) 16 cm² (b) 27 cm²
2. (a) 24 cm² (b) 16 cm² (c) 1900 mm²
 (d) 15 cm² (e) 20 cm² (f) 33 cm²
3. (a) 22 cm (b) 20 cm (c) 190 mm
 (d) 24 cm (e) 22 cm (f) 28 cm

| 4. | <i>Area</i> | <i>Perimeter</i> |
|-----|--------------------|------------------|
| (a) | 21 cm ² | 22 cm |
| (b) | 22 mm ² | 30 mm |
| (c) | 24 cm ² | 24 cm |
| (d) | 54 cm ² | 38 cm |

5. (a) 12 cm² (b) 24 cm² (c) 26.97 cm² (d) 60 cm²

Answers

9.4

| 6. | <i>Area</i> | <i>Perimeter</i> |
|-----|-----------------------|------------------|
| (a) | 36.07 cm ² | 28 cm |
| (b) | 78.94 cm ² | 43.6 cm |
| (c) | 14.96 cm ² | 35.6 cm |
| (d) | 29.48 cm ² | 29.6 cm |

7. 20 m²

8. 2.4 m²

9. (a) 20.5 m² (b) £10.25

10. 234 cm²

9.5 The Area of a Triangle

1. (a) 24 cm² (b) 17.5 cm² (c) 48 cm² (d) 600 mm²
 (e) 12 cm² (f) 24 cm² (g) 17.55 cm² (h) 21.84 mm²

2. Both triangles have the same base and height; they each fill half the rectangle.

3. (a) 24 cm² (b) 48 cm²

4. 24 cm²

5. (a) 27.5 cm² (b) 38.5 cm² (c) 35 cm² (d) 52.5 cm²

6. 24 cm²

7. (a) 26.24 cm² (b) 20.8 cm²

8. about 15.3 cm²

9. about 20.3 cm²

10. 6.8 cm²

11. 60 cm²

Practice Book *UNIT 10 Arithmetic: Fractions*

Answers

10.1 Fractions

1. (a) $\frac{8}{9}$ (b) $\frac{3}{8}$ (c) $\frac{1}{6}$ (d) $\frac{5}{6}$ (e) $\frac{1}{4}$
 (f) $\frac{7}{8}$ (g) $\frac{2}{5}$ (h) $\frac{3}{7}$ (i) $\frac{3}{16}$

2. Possible answers:

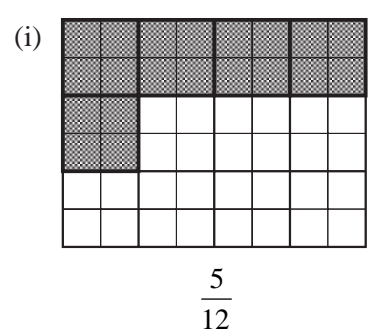
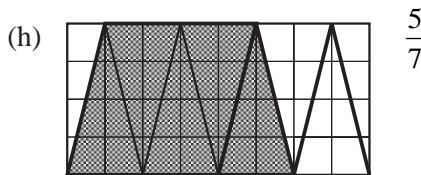
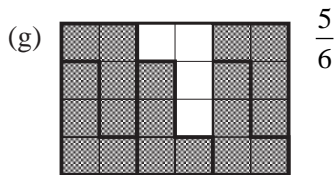
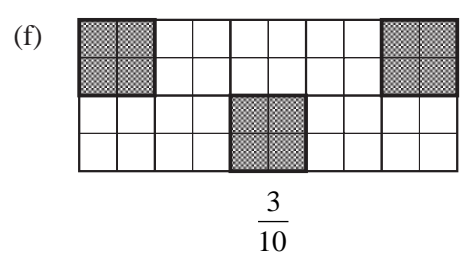
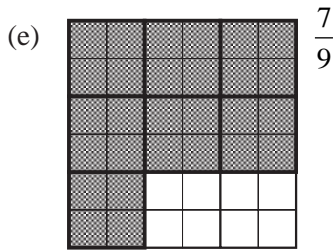
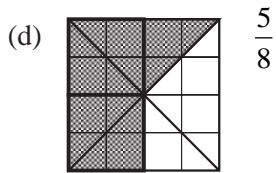
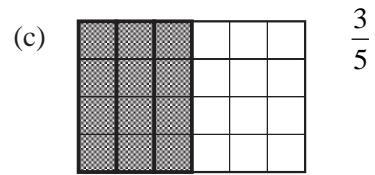
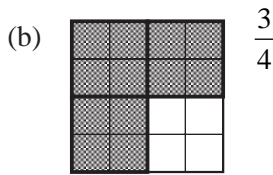
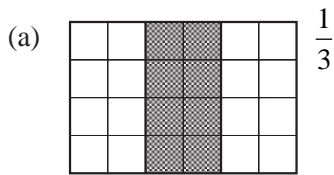

3. (a) and (b): possible answer:

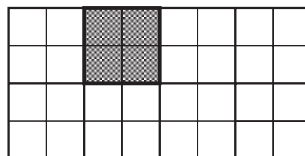

(c) $\frac{7}{8}$

4. Possible answers:

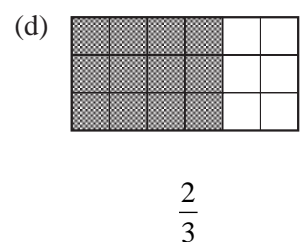
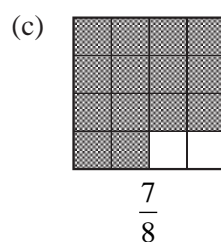
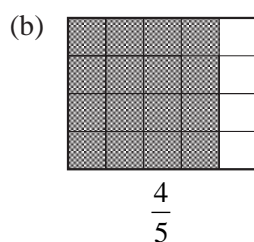
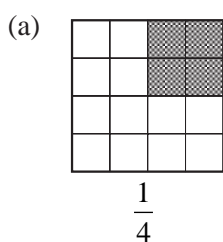

10.1

Answers

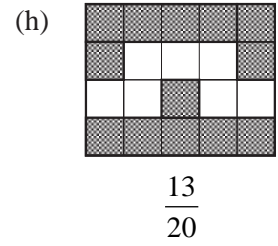
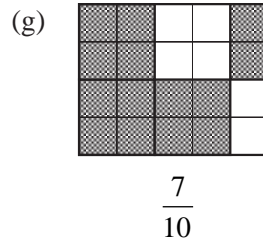
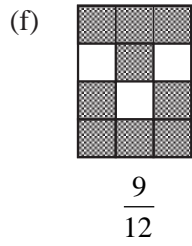
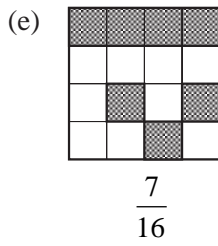

5. Possible answers:

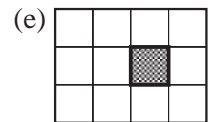
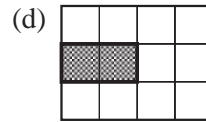
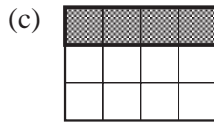
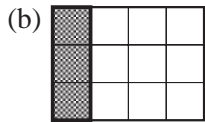
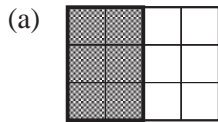

6. (b) and (c): possible answers:

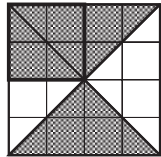
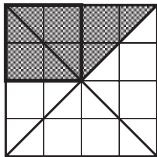

(d) $\frac{5}{8}$ shaded

(e) $\frac{3}{8}$ unshaded

7. $\frac{4}{7}$

8. $\frac{8}{12} = \frac{2}{3}$

9. (a) $\frac{17}{20}$ (b) $\frac{3}{20}$

10. (a) $\frac{7}{10}$ (b) $\frac{3}{10}$

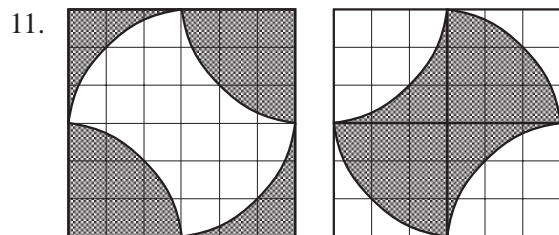

etc.

10.2 Equivalent Fractions

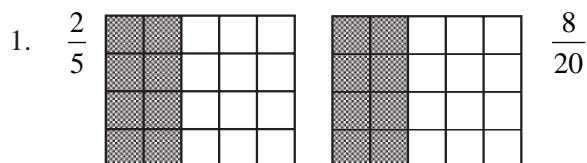

10.2

Answers

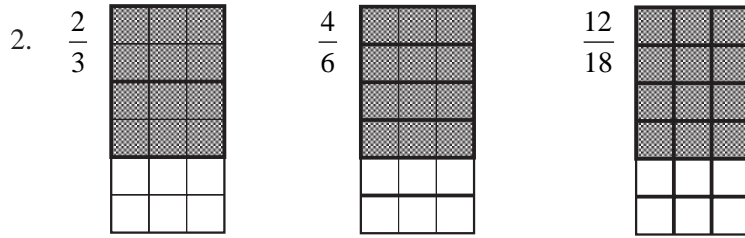

3. $\frac{3}{5} = \frac{6}{10} = \frac{12}{20}$

4. (a) $\frac{1}{2} = \frac{2}{4} = \frac{3}{6} = \frac{4}{8} = \frac{5}{10} = \frac{6}{12} = \frac{7}{14} = \frac{8}{16}$ (b) $\frac{1}{3} = \frac{2}{6} = \frac{3}{9} = \frac{4}{12} = \frac{5}{15}$

(c) $\frac{1}{4} = \frac{2}{8} = \frac{3}{12} = \frac{4}{16}$ (d) $\frac{1}{5} = \frac{2}{10} = \frac{3}{15}$ (e) $\frac{1}{6} = \frac{2}{12}$

(f) $\frac{1}{7} = \frac{2}{14}$ (g) $\frac{1}{8} = \frac{2}{16}$

5. (a) $\frac{3}{4} = \frac{6}{8}$ (b) $\frac{2}{5} = \frac{4}{10}$ (c) $\frac{5}{7} = \frac{10}{14}$ (d) $\frac{3}{4} = \frac{9}{12}$ (e) $\frac{2}{5} = \frac{6}{15}$ (f) $\frac{2}{3} = \frac{6}{9}$
 (g) $\frac{3}{8} = \frac{6}{16}$ (h) $\frac{2}{7} = \frac{4}{14}$ (i) $\frac{2}{3} = \frac{8}{12}$ (j) $\frac{3}{4} = \frac{15}{20}$ (k) $\frac{3}{5} = \frac{12}{20}$ (l) $\frac{5}{7} = \frac{15}{21}$

6. (a) $\frac{1}{2} > \frac{1}{3}$ (b) $\frac{1}{4} > \frac{1}{5}$ (c) $\frac{1}{6} > \frac{1}{7}$ (d) $\frac{1}{10} < \frac{1}{9}$ (e) $\frac{1}{2} < \frac{2}{3}$ (f) $\frac{3}{4} > \frac{2}{3}$
 (g) $\frac{2}{5} < \frac{1}{2}$ (h) $\frac{7}{10} < \frac{7}{8}$ (i) $\frac{5}{7} > \frac{3}{5}$ (j) $\frac{5}{6} > \frac{5}{7}$ (k) $\frac{2}{3} < \frac{5}{7}$ (l) $\frac{4}{5} < \frac{5}{6}$

7. (a) $\frac{15}{30} = \frac{1}{2}$ (b) $\frac{6}{9} = \frac{2}{3}$ (c) $\frac{9}{12} = \frac{3}{4}$ (d) $\frac{3}{12} = \frac{1}{4}$ (e) $\frac{8}{18} = \frac{4}{9}$
 (f) $\frac{16}{40} = \frac{2}{5}$ (g) $\frac{30}{50} = \frac{3}{5}$ (h) $\frac{14}{21} = \frac{2}{3}$ (i) $\frac{16}{24} = \frac{2}{3}$ (j) $\frac{17}{51} = \frac{1}{3}$
 (k) $\frac{144}{200} = \frac{18}{25}$ (l) $\frac{132}{216} = \frac{11}{18}$

8. (a) $\frac{1}{10}, \frac{1}{9}, \frac{1}{7}, \frac{1}{4}, \frac{1}{3}$ (b) $\frac{2}{9}, \frac{4}{7}, \frac{3}{5}, \frac{2}{3}$ (c) $\frac{2}{7}, \frac{4}{9}, \frac{3}{5}, \frac{5}{6}$
 (d) $\frac{2}{7}, \frac{2}{5}, \frac{3}{7}, \frac{3}{5}, \frac{5}{7}$ (e) $\frac{1}{9}, \frac{3}{7}, \frac{5}{9}, \frac{5}{7}, \frac{7}{9}$

10.2

Answers

9. (a) $\frac{1}{3}$ (b) $\frac{3}{4}$ (c) $\frac{4}{5}$ (d) $\frac{9}{13}$ (e) $\frac{3}{4}$
 (f) $\frac{5}{8}$ (g) $\frac{1}{4}$ (h) $\frac{2}{5}$ (i) $\frac{22}{25}$

10. (a) False: $\frac{3}{5} > \frac{3}{7}$ (b) False: $\frac{3}{8} = \frac{33}{88}$ (c) True (d) True (e) False: $\frac{3}{8} < \frac{1}{2}$
 (f) False: $\frac{1}{6} > \frac{1}{7}$ (g) True (h) True (i) False: $\frac{44}{99} = \frac{4}{9}$

10.3 Fractions of Quantities

1. (a) 6 (b) 2 (c) 3 (d) 4 (e) 6 (f) 10
 (g) 2 (h) 8 (i) 5 (j) 8 (k) 8 (l) 4
2. (a) 18 (b) 16 (c) 6 (d) 4 (e) 25 (f) 16
 (g) 9 (h) 35 (i) 24 (j) 20 (k) 27 (l) 49
3. 18 marks
4. 191 girls
5. 12 pupils
6. (a) 153 pupils (b) 357 pupils
7. 5 houses
8. 225 foreign stamps
9. Ben: £18: Chris: £27
10. 33 pupils

10.4

Answers

10.4 Mixed Numbers and Vulgar (Improper) Fractions

1. (a) $1\frac{1}{2}$, $\frac{3}{2}$ (b) $1\frac{3}{4}$, $\frac{7}{4}$ (c) $1\frac{1}{3}$, $\frac{4}{3}$ (d) $2\frac{1}{5}$, $\frac{11}{5}$
 (e) $2\frac{5}{8}$, $\frac{21}{8}$ (f) $3\frac{1}{4}$, $\frac{13}{4}$ (g) $1\frac{4}{9}$, $\frac{13}{9}$

2. (a) $1\frac{1}{5} = \frac{6}{5}$: for example, 

(b) $2\frac{1}{4} = \frac{9}{4}$: for example, 

(c) $2\frac{2}{3} = \frac{8}{3}$: for example, 

3. (a) $\frac{7}{2} = 3\frac{1}{2}$: for example, 

(b) $\frac{8}{3} = 2\frac{2}{3}$: for example, 

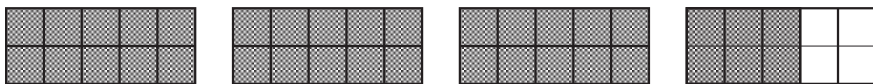
(c) $\frac{18}{5} = 3\frac{3}{5}$: for example, 

4. (a) $4\frac{1}{2}$ (b) $1\frac{1}{3}$ (c) $1\frac{2}{3}$ (d) $2\frac{2}{5}$ (e) $3\frac{3}{5}$
 (f) $1\frac{2}{7}$ (g) $1\frac{2}{9}$ (h) $2\frac{1}{4}$ (i) $1\frac{3}{5}$ (j) $2\frac{4}{9}$
 (k) $1\frac{1}{5}$ (l) $2\frac{4}{5}$ (m) $1\frac{6}{7}$ (n) $2\frac{5}{7}$ (o) $2\frac{2}{9}$
5. (a) $\frac{8}{5}$ (b) $\frac{9}{2}$ (c) $\frac{9}{4}$ (d) $\frac{13}{2}$ (e) $\frac{22}{3}$
 (f) $\frac{17}{3}$ (g) $\frac{59}{7}$ (h) $\frac{22}{5}$ (i) $\frac{36}{5}$ (j) $\frac{32}{9}$
 (k) $\frac{31}{7}$ (l) $\frac{19}{5}$ (m) $\frac{55}{9}$ (n) $\frac{23}{3}$ (o) $\frac{39}{8}$

10.4

Answers

6. $3\frac{1}{4}$, $\frac{18}{5}$, $5\frac{1}{3}$, $\frac{17}{3}$, $6\frac{1}{2}$

7. (a) $2\frac{3}{5} = \frac{13}{5}$ (b) $3\frac{4}{7} < \frac{26}{7}$ (c) $3\frac{7}{8} < 4$ (d) $6\frac{1}{2} < \frac{22}{3}$

(e) $4\frac{1}{4} < \frac{19}{4}$ (f) $\frac{3}{2} > \frac{2}{3}$ (g) $\frac{2}{5} < \frac{1}{2}$ (h) $\frac{7}{10} < \frac{7}{8}$

(i) $\frac{5}{7} > \frac{3}{5}$ (j) $\frac{5}{6} > \frac{5}{7}$ (k) $\frac{2}{3} < \frac{5}{6}$ (l) $\frac{4}{5} < \frac{5}{6}$

8. $3\frac{5}{8} = \frac{3 \times 8 + 5}{8} = \frac{29}{8} = \frac{29 \times 2}{8 \times 2} = \frac{58}{16}$

9. 1250 sheets

10. $\frac{44}{12} = \frac{11}{3} = 3\frac{2}{3}$ years

Practice Book *UNIT 11*

Data Collection and Presentation

Answers

11.1 Types of Data

- David Darby - Transport to School ; Frederick Franks - Age
 - Age ; Height (c) Name ; Primary School ; Transport to School ; Glasses
- (iii) ; (iv) (b) (ii) ; (v) ; (vi) ; (viii) ; (ix) (c) (i) ; (vii) ; (x)
- Must be whole number (b) Can be any number
 - Colour ; Trailer / Caravan (d) 33 mph (e) 2 (f) Red
 - 36 mph (h) L
- (i) Name ; Favourite Food ; TV Show ; Pop Group
 - Time (dependent on the accuracy)
 - Age (when given to the nearest year or month, etc.)

11.2 Collecting Data

1. (a)

| | <i>Frequency</i> |
|-------|------------------|
| | 5 |
| | 9 |
| | 7 |
| | 3 |
| | 6 |
| TOTAL | 30 |

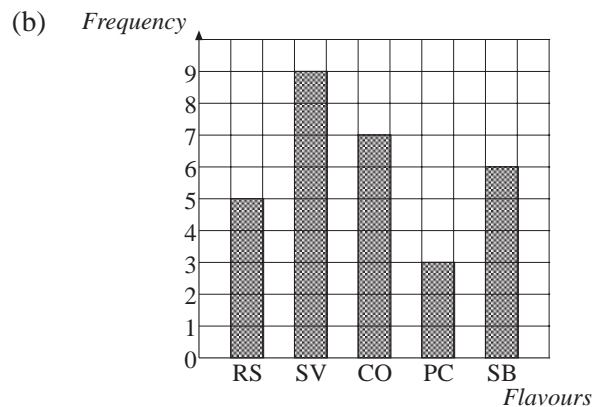



(c)

Ready Salted 

Salt and Vinegar 

Cheese and Onion 

Prawn Cocktail 

Smokey Bacon 

 represents 1 person

11.2

Answers

(d)

| <i>Flavour</i> | <i>Frequency</i> | <i>Calculation</i> | <i>Angle</i> |
|------------------|------------------|-----------------------------------|--------------|
| Ready Salted | 5 | $\frac{5}{30} \times 360^\circ =$ | 60° |
| Salt and Vingar | 9 | $\frac{9}{30} \times 360^\circ =$ | 108° |
| Cheese and Onion | 7 | $\frac{7}{30} \times 360^\circ =$ | 84° |
| Prawn Cocktail | 3 | $\frac{3}{30} \times 360^\circ =$ | 36° |
| Smokey Bacon | 6 | $\frac{6}{30} \times 360^\circ =$ | 72° |
| TOTAL | | | 360° |

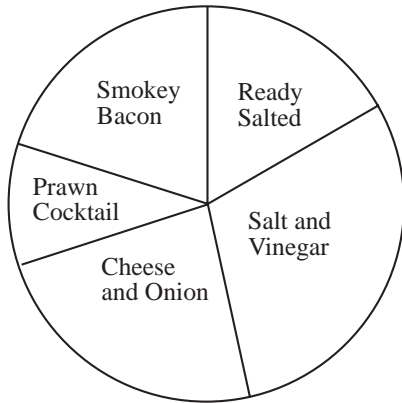

(e) Salt and Vinegar

6. (a) 12 years

(c)

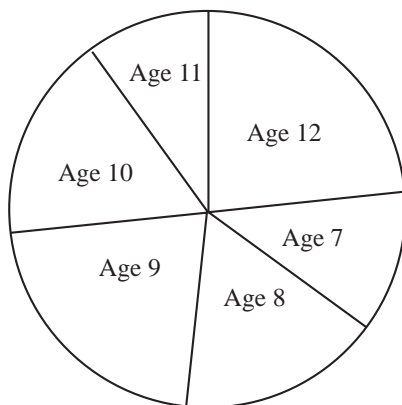

(b)

| <i>Age</i> | <i>Calculation</i> | <i>Angle</i> |
|------------|------------------------------------|--------------|
| 7 | $\frac{7}{60} \times 360^\circ =$ | 42° |
| 8 | $\frac{10}{60} \times 360^\circ =$ | 60° |
| 9 | $\frac{13}{60} \times 360^\circ =$ | 78° |
| 10 | $\frac{10}{60} \times 360^\circ =$ | 60° |
| 11 | $\frac{6}{60} \times 360^\circ =$ | 36° |
| 12 | $\frac{14}{60} \times 360^\circ =$ | 84° |
| Total | | 360° |

11.2

Answers

7. (a) 4 (b) 6 (c) More popular with girls
 (d) 5 (e) Rabbits (f) Rabbits

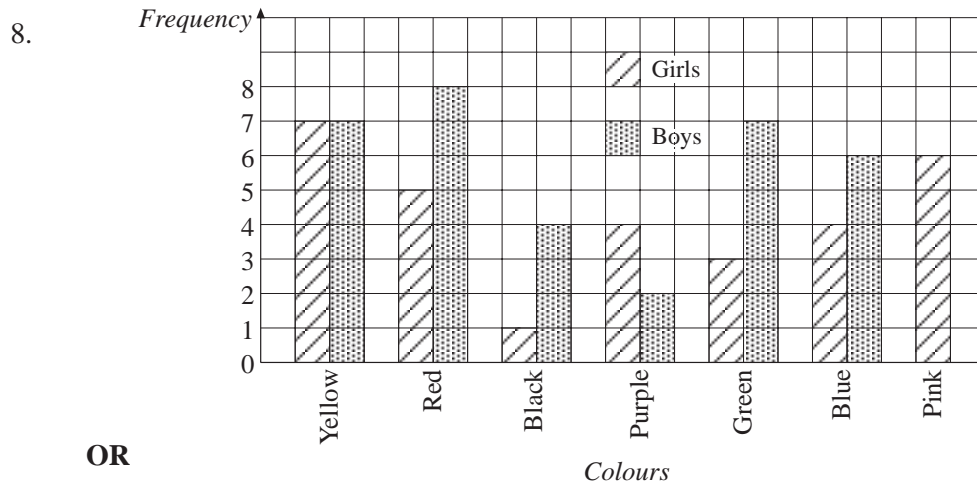
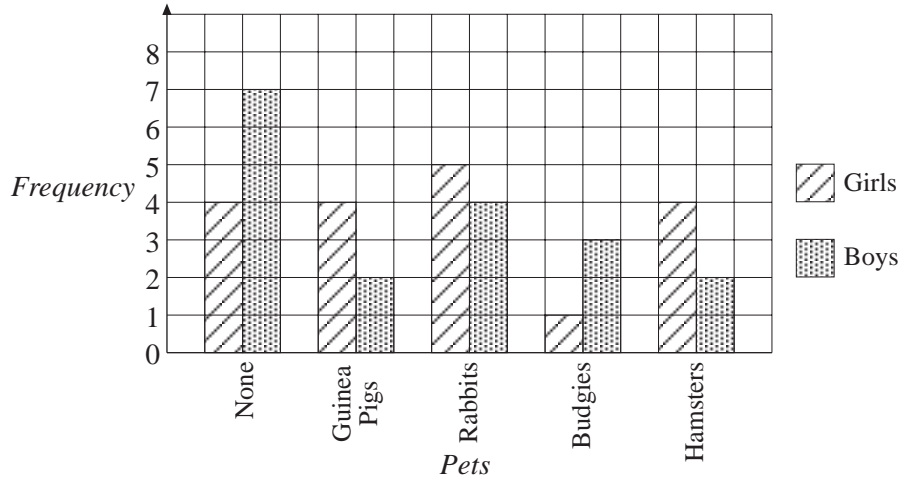

OR

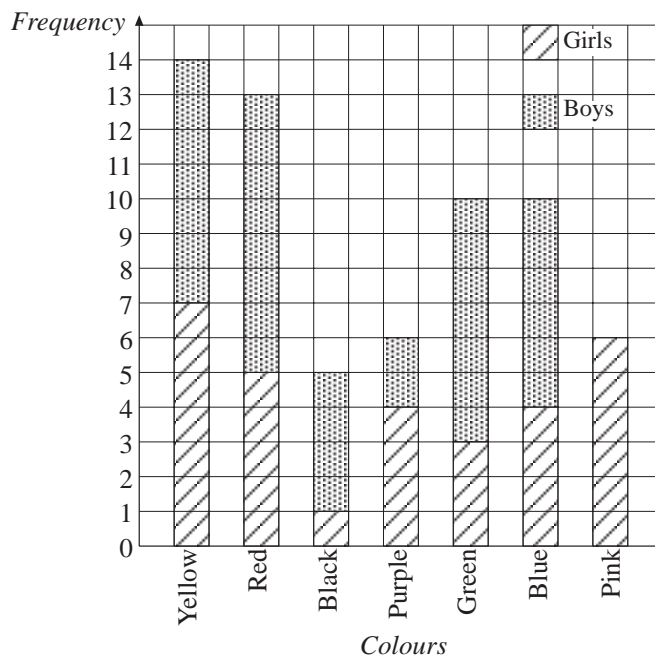

11.2

Answers

9. (a)

| <i>Score</i> | <i>Tally</i> | <i>Frequency</i> |
|--------------|--------------|------------------|
| 1 | | 12 |
| 2 | | 9 |
| 3 | | 10 |
| 4 | | 12 |
| 5 | | 8 |
| 6 | | 9 |

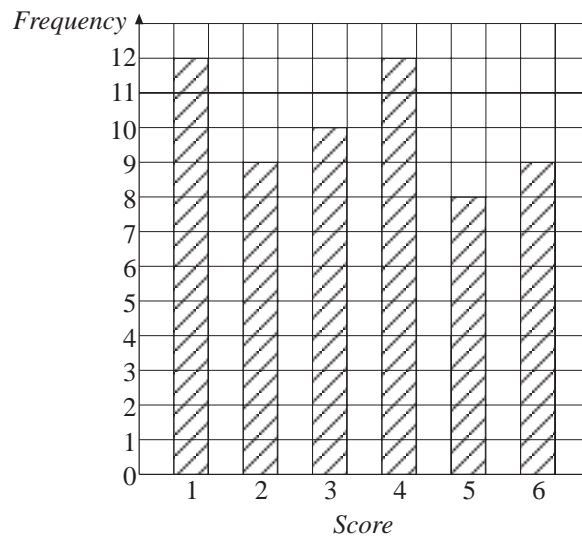

We would expect 10 of each score. All frequencies are reasonably close to 10, so we conclude that the dice probably is fair; rolling the dice many more times and recording the results would give a more accurate indication.

Practice Book *UNIT 12 Arithmetic: Revision*

Answers

12.1 Arithmetic with Whole Numbers and Decimals

- | | | | | | |
|----|-------------|------------|-----------|------------|------------|
| 1. | (a) 156 | (b) 1236 | (c) 8.87 | (d) 16.1 | (e) 1312 |
| | (f) 1391 | (g) 157 | (h) 193 | (i) 8.32 | (j) 14.61 |
| | (k) 11.80 | (l) 15.01 | (m) 19.6 | (n) 11.5 | (o) 9.15 |
| 2. | (a) 370 | (b) 47.1 | (c) 86.2 | (d) 5700 | (e) 871 |
| | (f) 8200 | (g) 11.7 | (h) 8.4 | (i) 1.892 | (j) 0.84 |
| | (k) 0.00872 | (l) 0.0421 | (m) 8201 | (n) 0.0523 | (o) 1.862 |
| 3. | (a) 328 | (b) 26.1 | (c) 10.4 | (d) 452.9 | (e) 19.0 |
| | (f) 96 | (g) 131.2 | (h) 22.47 | (i) 42.35 | (j) 1.444 |
| | (k) 4.56 | (l) 3.78 | (m) 0.126 | (n) 2.526 | (o) 0.1942 |
| 4. | (a) 1056 | (b) 714 | (c) 784 | (d) 882 | (e) 1147 |
| | (f) 1932 | (g) 33.6 | (h) 54.4 | (i) 117.6 | (j) 7.68 |
| | (k) 4.35 | (l) 49.68 | (m) 4.032 | (n) 72.42 | (o) 13.482 |
| 5. | (a) 6 | (b) 12 | (c) 123 | (d) 212 | (e) 123 |
| | (f) 231 | (g) 111 | (h) 123 | (i) 543 | (j) 324 |
| | (k) 312 | (l) 537 | (m) 84 | (n) 0.87 | (o) 4.51 |
| | (p) 14.4 | (q) 12 | (r) 2.14 | | |

12.2 Problems with Arithmetic

1. £11.05
2. £55.96
3. £112
4. 23 bars
5. £217; change = £ 2.83
6. £259
7. £10.88
8. 201 tickets
9. £1.78 per mile
10. 11 910 ml = 11.91 litres

Practice Book *UNIT 13 Searching for Pattern*

Answers

13.1 Pictorial Logic

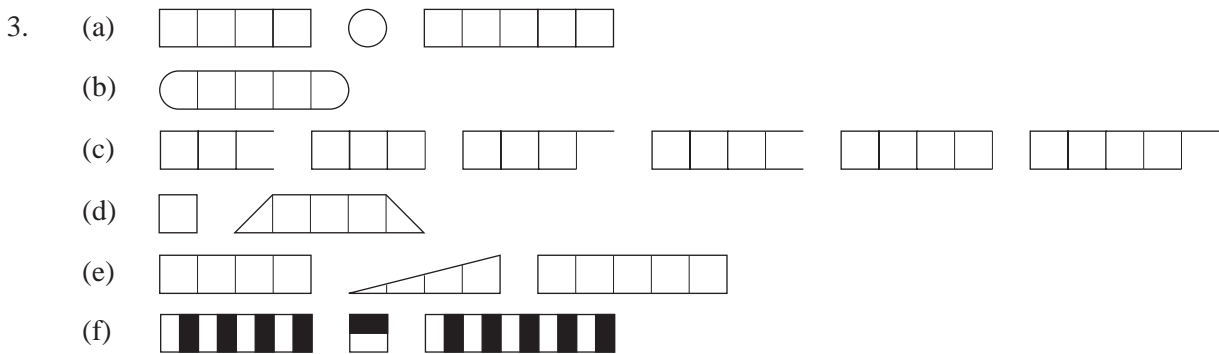
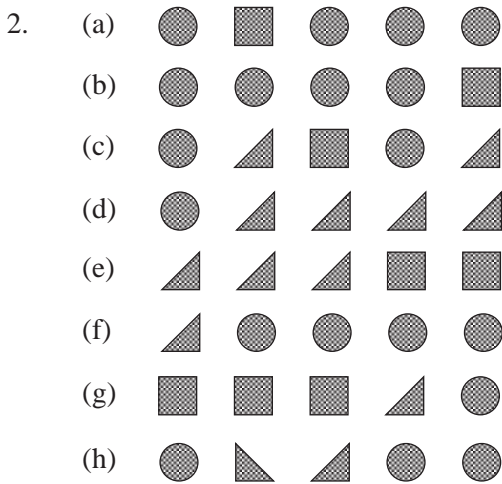
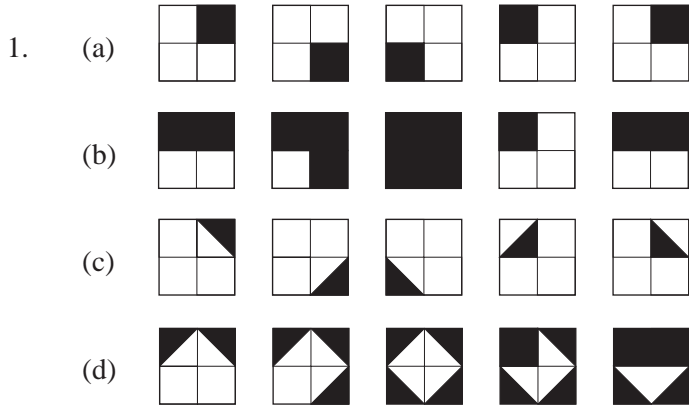

6. (a) circle (b) circle (c) circle
 (d) 2 squares (e) 3 squares (f) 10 squares

13.1

Answers

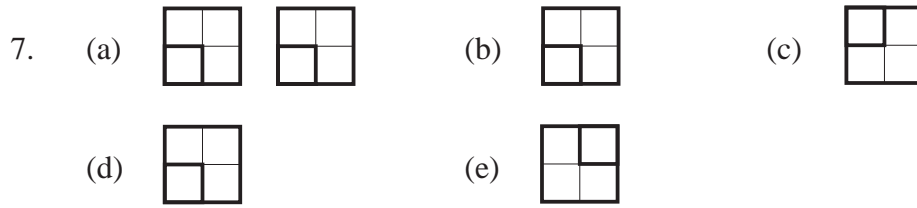

13.2 Extending Number Sequences

1. (a) 22, 25, 28, 31 (b) 41, 47, 53, 59 (c) 33, 41, 50, 60
 (d) 50, 64, 80, 98 (e) 3, -4, -12, -21 (f) 47, 51, 54, 56
 (g) 16, 22, 29, 37

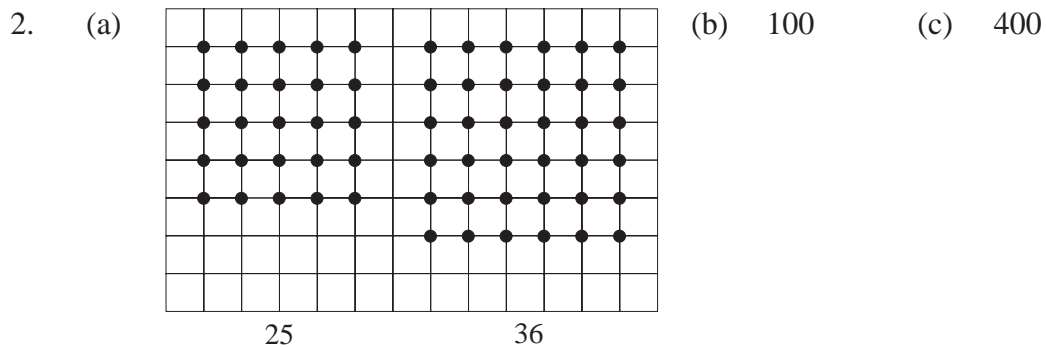

(d) Differences = 3, 5, 7, 9, 11 ; 13

3. (a) (i) 35, 48, 63
 (ii) 37, 50, 65
 (iii) 46, 59, 74
 (iv) 41, 54, 69

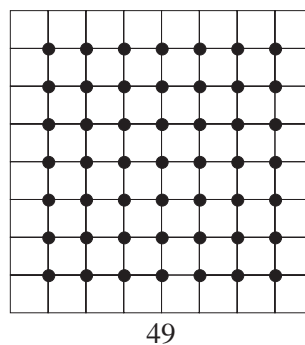

- (b) (i) Square number sequence minus 1 (ii) Square number sequence plus 1
 (iii) Square number sequence plus 10 (iv) Square number sequence plus 5

13.2

Answers

4. (a)

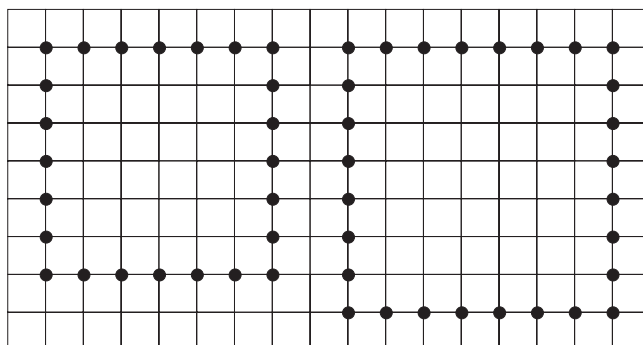

8, 12, 16, 20, 24, 28, 32, 36, 40, 44

(b)

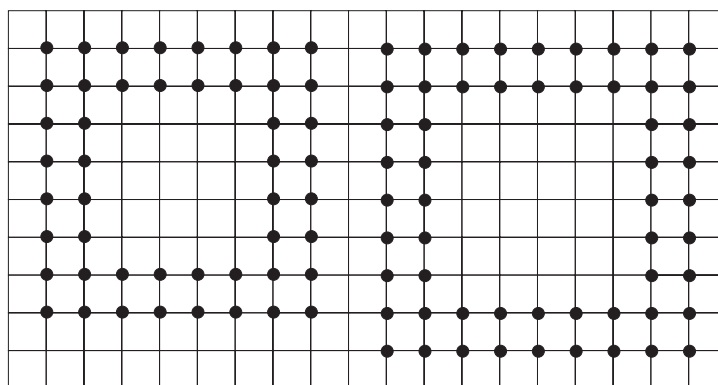

16, 24, 32, 40, 48, 56, 64, 72, 80, 88

(c)

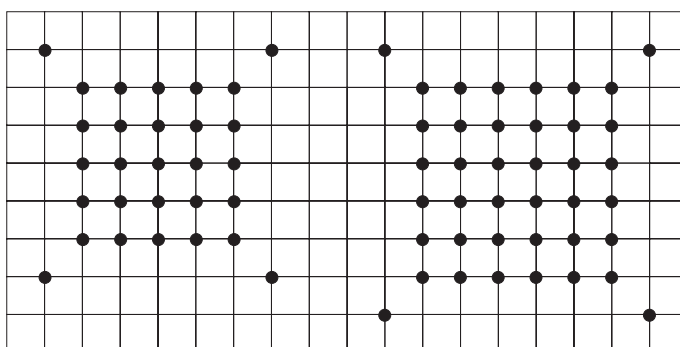

5, 8, 13, 20, 29, 40, 53, 68, 85, 104

5. (a)

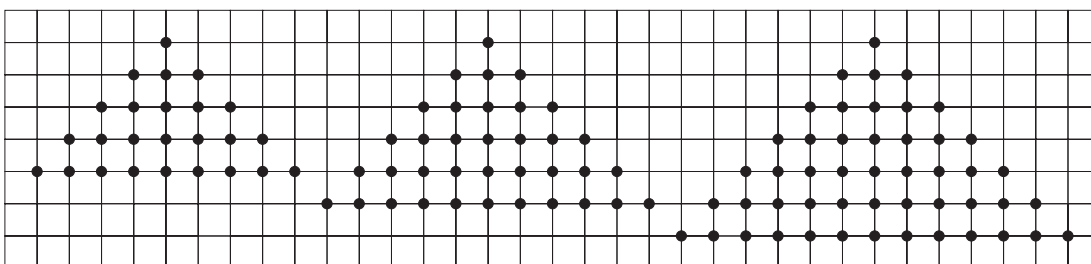

4, 9, 16, 25, 36, 49, 64, 81

13.2

Answers

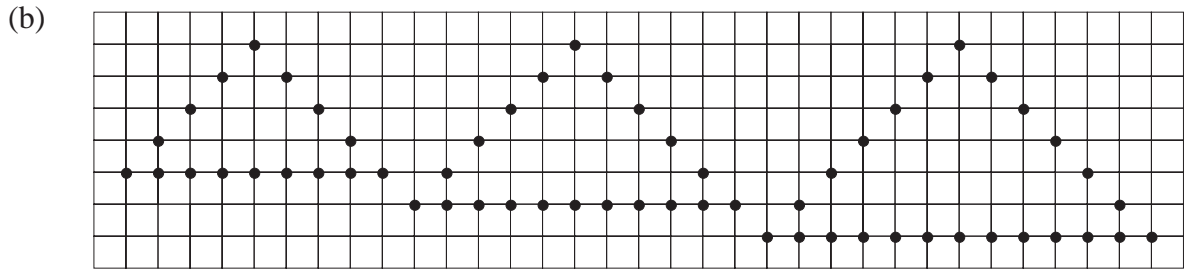

4, 8, 12, 16, 20, 24, 28, 32

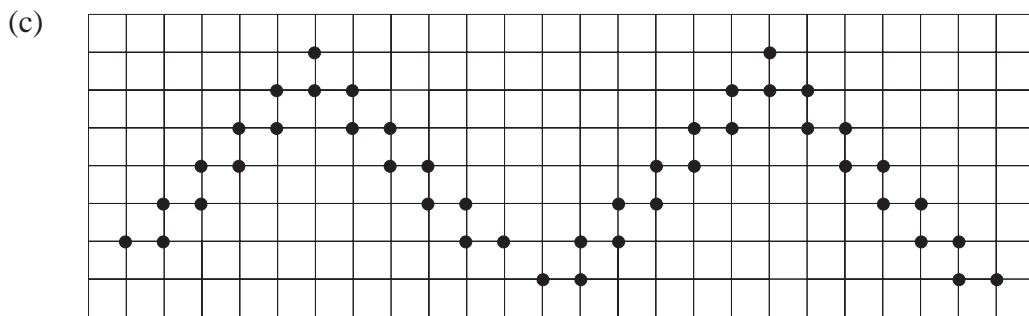

4, 8, 12, 16, 20, 24, 28, 32

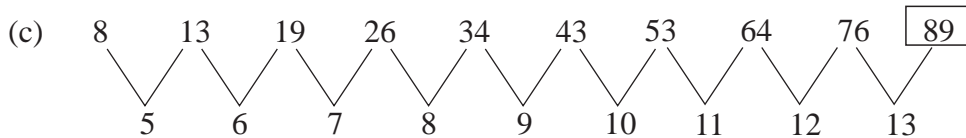
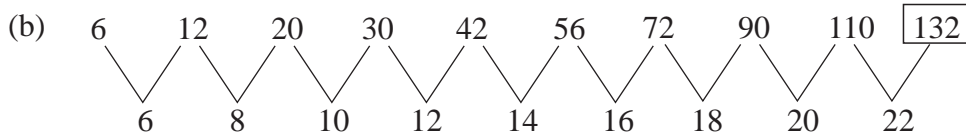
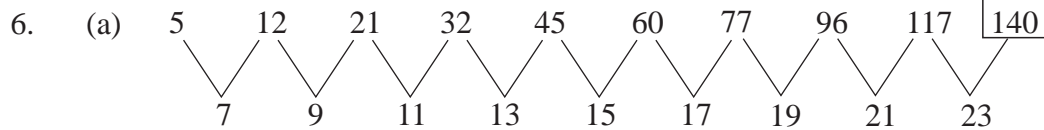

7. 55, 6765

8. (a) 16, 26, 42, 68, 110

(b) 18, 29, 47, 76, 123

(c) 31, 50, 81, 131, 212

(d) 48, 77, 125, 202, 327

9. (a) 1, 4, ..., ..., 60, 97

(b) 1, 6, 7, 13

(c) 2, 1, 3, 4

13.2

Answers

10. (a) (i) 6 (4th term) (ii) 11 (5th term) (iii) 20 (6th term)
 (b) 125, 230, 423 (c) 2, 4, 8 (d) 57, 105, 193

13.3 Patterns and Matchsticks

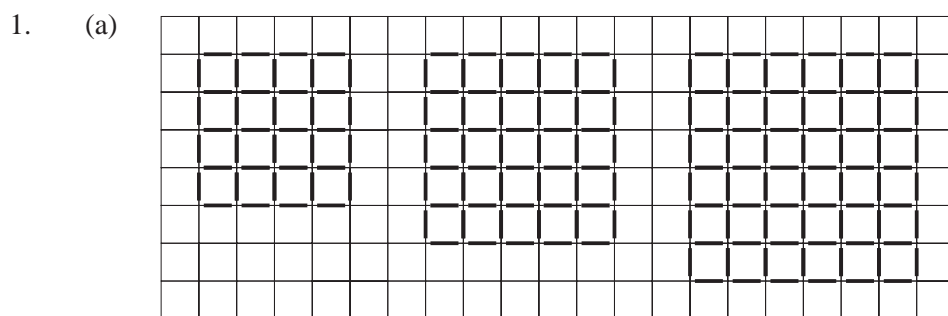

- (b) 4, 12, 24, 40, 60, 84 (c) 112, 144

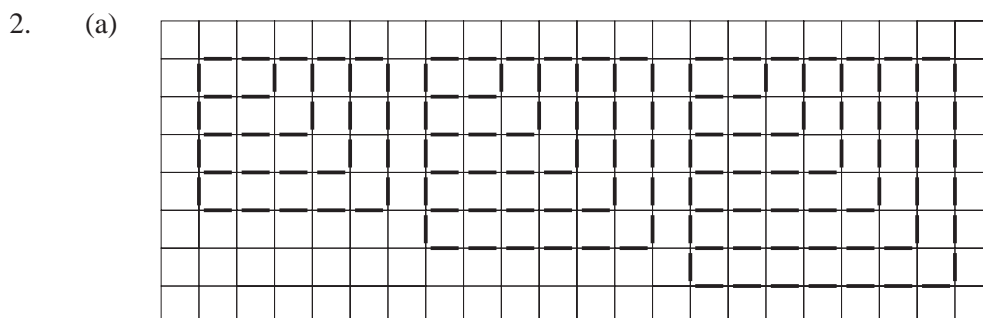

- (b) 141 (c) 8th shape

3. 95 matches

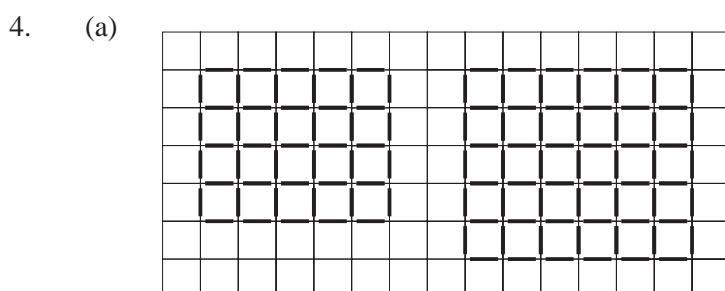

- (b) 141 (c) 8th shape

5. (a) 20, 24 (b) $4n$ (c) 22nd shape

6. $8n$

7. (a) 42 (b) $4n + 2$ (c) 12th rectangle

13.4

Answers

4.
$$\begin{array}{cccc} 1 & 2 & 3 & 4 \\ 3 & 5 & 7 & \\ 8 & 12 & & \\ 20 & & & \end{array}, \begin{array}{cccc} 1 & 2 & 3 & 4 \\ 3 & 5 & 7 & 9 \\ 8 & 12 & 16 & \\ 20 & 28 & & \\ 48 & & & \end{array}, \begin{array}{cccc} 1 & 2 & 3 & 4 \\ 3 & 5 & 7 & 9 \\ 8 & 12 & 16 & 20 \\ 20 & 28 & 36 & \\ 48 & 64 & & \\ 112 & & & \end{array}$$

5.
$$\begin{array}{cccc} 1 & 2 & 1 & 2 \\ 3 & 3 & 3 & 3 \\ 6 & 6 & 6 & \\ 12 & 12 & & \\ 24 & & & \end{array}, \begin{array}{cccc} 1 & 2 & 1 & 2 \\ 3 & 3 & 3 & 3 \\ 6 & 6 & 6 & 6 \\ 12 & 12 & 12 & \\ 24 & 24 & & \\ 48 & & & \end{array}, \begin{array}{cccc} 1 & 2 & 1 & 2 \\ 3 & 3 & 3 & 3 \\ 6 & 6 & 6 & 6 \\ 12 & 12 & 12 & 12 \\ 24 & 24 & 24 & \\ 48 & 48 & & \\ 96 & & & \end{array}$$

6.
$$\begin{array}{cccc} 1 & 3 & 5 & 7 \\ 4 & 8 & 12 & \\ 12 & 20 & & \\ 32 & & & \end{array}, \begin{array}{cccc} 1 & 3 & 5 & 7 \\ 4 & 8 & 12 & 16 \\ 12 & 20 & 28 & \\ 32 & 48 & & \\ 80 & & & \end{array}, \begin{array}{cccc} 1 & 3 & 5 & 7 \\ 4 & 8 & 12 & 16 \\ 12 & 20 & 28 & 36 \\ 32 & 48 & 64 & \\ 80 & 112 & & \\ 192 & & & \end{array}$$

7. (a)
$$\begin{array}{cccc} 2 & 10 & 20 & 20 & 10 & 2 \\ 2 & 12 & 30 & 40 & 30 & 12 & 2 \\ 2 & 14 & 42 & 70 & 70 & 42 & 14 & 2 \end{array}$$

(b) Apex of triangle contains *only* even numbers (1st and 2nd rows) from which remainder of triangle is built.

8. (a)
$$\begin{array}{cccc} 3 & 3 & 3 & 3 \\ 6 & 6 & 6 & \\ 12 & 12 & & \\ 24 & & & \end{array}$$

(d) 8th diagram

9.
$$\begin{array}{cccc} 1 & 2 & 3 & 4 \\ 2 & 6 & 12 & \\ 12 & 72 & & \\ 864 & & & \end{array}, \begin{array}{cccc} 1 & 2 & 3 & 4 \\ 2 & 6 & 12 & 20 \\ 12 & 72 & 240 & \\ 864 & 17 & 280 & \\ 14 & 929 & 920 & \end{array}$$

13.4

Answers

10. 1 2 3 4 5 6 , 1 2 3 4 5 6 7
 3 5 7 9 1 3 5 7 9 1 3
 8 2 6 0 8 2 6 0 4
 0 8 6 0 8 6 4
 8 4 8 4 0
 2 2 4
 6

Largest number: 9

Practice Book *UNIT 14 Time and Timetables*

Answers

14.1 Telling the Time

- | | | | | | | |
|----|-----|---------------------|-------|-----|----------------------|------|
| 1. | (a) | Eight o'clock; | 8:00 | (b) | Half past two ; | 2:30 |
| | (c) | Quarter past eight; | 8:15 | (d) | Quarter to three; | 2:45 |
| | (e) | Ten to eight | 7:50 | (f) | Twenty five to four; | 3:35 |
| | (g) | Five past eleven; | 11:05 | (h) | Five to nine; | 8:55 |
| | (i) | Twenty past seven | 7:20 | | | |

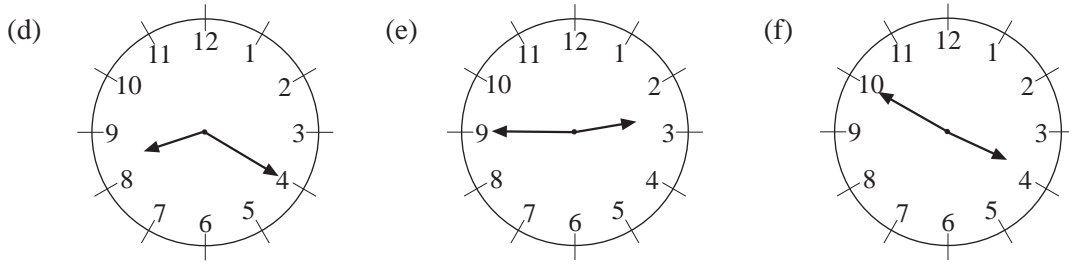
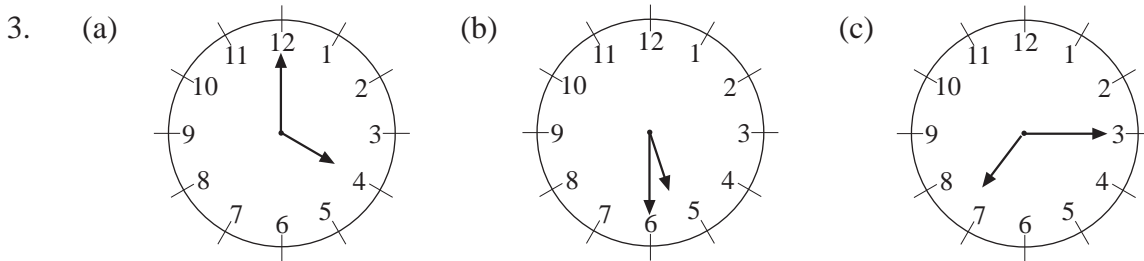
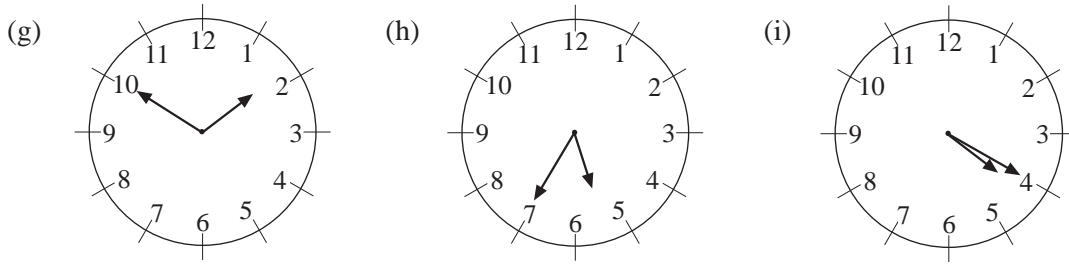
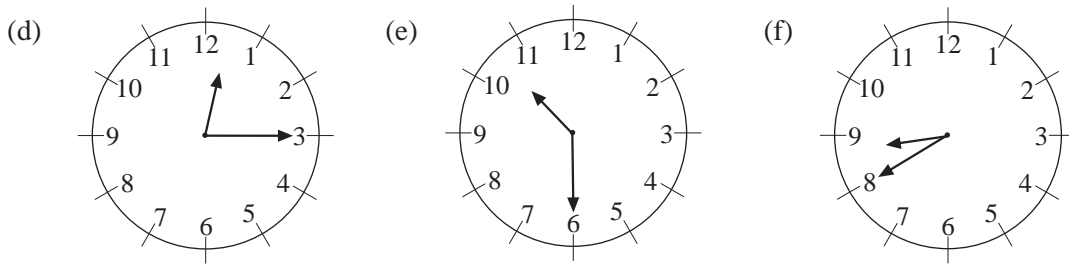
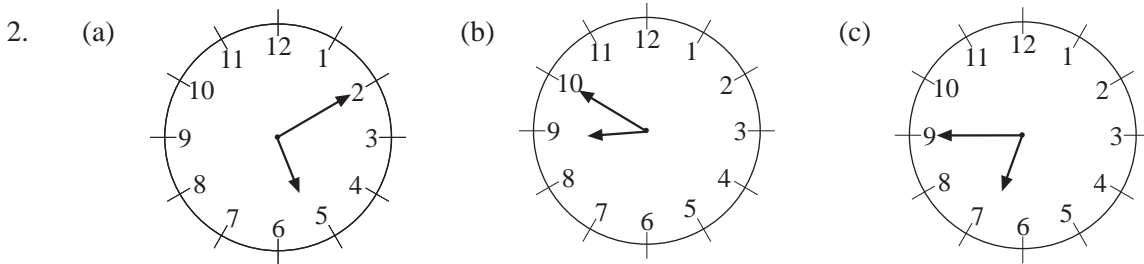

14.1

Answers

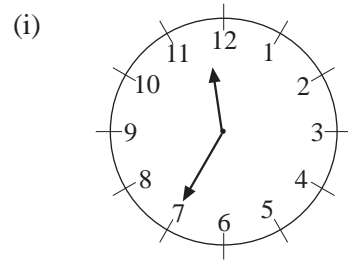
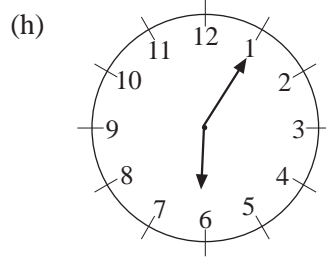
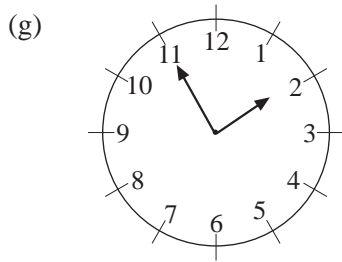

4. (a) Half past nine (b) Four o'clock (c) Twenty five past four
 (d) Quarter to nine (e) Twenty five to eight (f) Five past nine
5. (a) 8:00 (b) 6:45 (c) 5:10 (d) 6:30
 (e) 2:50 (f) 3:55 (g) 8:35 (h) 2:40

6. (a) (b) Eighteen minutes to eight

7. (a) 1 (b) 5 (c) 1 (d) 2
8. (a) Fourteen minutes to eight (b) Four minutes to eight or 7:56
9. Twenty five past four; 4:25

14.2 12- and 24-hour Clocks

1. (a) 0942 (b) 2328 (c) 1114 (d) 1913 (e) 2121
 (f) 1618 (g) 1005 (h) 0015 (i) 1215
2. (a) 0745 (b) 2350 (c) 2110
 (d) 0655 (e) 1715 (f) 1430
3. (a) 12:04 p.m. (b) 8:22 a.m. (c) 6:42 p.m.
 (d) 1:30 p.m. (e) 2:40 p.m. (f) 11:05 p.m.
 (g) 5:35 p.m. (h) 4:05 p.m. (i) 3:42 a.m.
4. (a) Half past two in the afternoon
 (b) Five to four in the afternoon
 (c) Quarter to eight in the morning
5. (a) a.m. (b) p.m. (c) p.m.
 (d) a.m. (e) p.m. (f) p.m.

14.2

Answers

6.

| | |
|---------------------|------|
| <i>Registration</i> | 0855 |
| <i>Lesson 1</i> | 0905 |
| <i>Lesson 2</i> | 1005 |
| <i>Lesson 3</i> | 1105 |
| <i>Lunch</i> | 1205 |
| <i>Lesson 4</i> | 1305 |
| <i>Lesson 5</i> | 1405 |
| <i>Day ends</i> | 1505 |

7. Twenty minutes past midnight

8. 1600 or 4:00 p.m.

14.3 Units of Time

1. 168 hours

2. (a) 720 hours (b) 672 hours, 696 hours (c) 8760 hours, 8784 hours

3. (a) 1440 minutes (b) 10 080 minutes

4. (a) 3600 seconds (b) 86 400 seconds

5. 1 April

6. 4 July

7. (a) Tuesday (b) 7 November

8. (a) 27 October; 3 November (b) 11 November

9. (a) Monday (b) Sunday

10. (a) Thursday (b) Monday

11. (e) 60 years before the current year.

14.4 Timetables

1. (a) 1006 (b) 1742 (c) Moûtiers (d) No

2. (a) 0826 (b) 0728 (c) 0736 (d) 1025 (e) 0620

14.4

Answers

-
3. (a) 0723 (b) 0923 (c) 0853 from Waterloo (d) 0619 from Waterloo
4. (a) 1702 (b) 2102 from Brussels (c) 1536 (d) 1639
5. (a) 1713 (b) 1515 (c) 1430 (d) 1303
6. (a) 1213 (b) 0937 (c) 1123 (d) 1007
7. (a) 1215 (b) 1509 (c) 1315 (d) opposite the Glen Orchy Hotel
8. (a) 30 August (b) 1100 (c) 1630 (d) No (e) 9 days
9. (a) Mondays and Fridays (b) Sunday (c) 1030
(d) Southampton (e) 1815
10. (a) JE309, Sunday (b) Saturday (c) 2 flights
(d) 0700 (e) 1855

14.5 Time Problems in Context

1. (a) 25 minutes (b) 47 minutes (c) 45 minutes
(d) 45 minutes (e) Yes (70 minutes)
2. (a) 122 minutes or 2 hour 2 minutes (b) 184 minutes or 3 hours 4 minutes
3. (a) Yes (1 hour 10 minutes) (b) 5 minutes (c) 33 minutes
(d) 46 minutes (e) 4 minutes
4. (a) 3 hours 45 minutes (b) 4 hours 15 minutes (c) 2 hours 38 minutes
(d) 1705 (e) 1135
5. (a) 8 hours 55 minutes (b) 8 hours 18 minutes (c) 9 hours 48 minutes
6. (a) 1:00 a.m. (b) 1:00 a.m. (c) 1:00 a.m. (d) 11:00 a.m.
7. (a) 1330 (b) 1915
8. 14 hours 10 minutes
9. £142.50
10. 12 hours

Practice Book *UNIT 15 Negative Numbers*

Answers

15.1 Addition and Subtraction

1. (a) 2 (b) 3 (c) 2
 (d) 3 (e) -1 (f) -5
 (g) -5 (h) 0 (i) -3
 (j) -4 (k) -5 (l) 0
2. (a) -2 (b) -2 (c) -2
 (d) -2 (e) -5 (f) -3
 (g) 7 (h) 11 (i) -4
 (j) -4 (k) -5 (l) 0
3. (a) $4 - 3 = 1$ and $4 + (-3) = 1$ (b) $(-2) + 5 = 3$ and $(-2) - (-5) = 3$
 (c) $(-7) + 5 = -2$ and $(-7) - (-5) = -2$ (d) $1 + 5 = 6$ and $1 - (-5) = 6$
 (e) $2 - 5 = -3$ and $2 + (-5) = -3$ (f) $-5 + 5 = 0$ and $(-5) - (-5) = 0$
 (g) $5 - 5 = 0$ and $5 + (-5) = 0$

4.

| | | | | | |
|----|----|----|----|----|---|
| + | -4 | -2 | 0 | 2 | 4 |
| -3 | -7 | -5 | -3 | -1 | 1 |
| -1 | -5 | -3 | -1 | 1 | 3 |
| 1 | -3 | -1 | 1 | 3 | 5 |
| 3 | -1 | 1 | 3 | 5 | 7 |

5.

| | | | | | |
|----|----|----|----|----|----|
| + | 0 | 1 | 2 | 3 | 4 |
| -5 | -5 | -4 | -3 | -2 | -1 |
| -4 | -4 | -3 | -2 | -1 | 0 |
| -3 | -3 | -2 | -1 | 0 | 1 |
| -2 | -2 | -1 | 0 | 1 | 2 |

15.1

Answers

6. (a) $4 + \underline{-3} = 1$ (b) $3 - \underline{9} = -6$ (c) $\underline{-6} + \underline{-1} = -7$
 (d) $\underline{-5} + 7 = 2$ (e) $\underline{-1} - 7 = -8$ (f) $4 - \underline{-3} = 7$
7. (a) 2, 0, -2, -4, -6 (b) 2, 5, 8, 11, 14
 (c) -1, -6, -11, -16, -21 (d) -9, -11, -13, -15, -17
 (e) -4, 0, 4, 8, 12 (f) -25, -30, -35, -40, -45
 (g) 6, 3, 0, -3, -6 (h) 0, 4, 8, 12, 16
8. 19 °C
9. 42 cm
10. $64 + 284 = 348$ years (There was no year 0, so $284 - (-64)$ *does* give the correct answer.)

15.2 Multiplication and Division

1. (a) -14 (b) -32 (c) 10
 (d) 18 (e) -21 (f) 40
 (g) 32 (h) -18 (i) 14
 (j) 20 (k) 0 (l) -40
2. (a) 5 (b) -3 (c) -6 (d) -2
 (e) 7 (f) -5 (g) -10 (h) 25
 (i) -40 (j) -2 (k) 10 (l) -6

3. (a)

| | | | | |
|----|----|----|-----|-----|
| × | 1 | 2 | 3 | 4 |
| -1 | -1 | -2 | -3 | -4 |
| -2 | -2 | -4 | -6 | -8 |
| -3 | -3 | -6 | -9 | -12 |
| -4 | -4 | -8 | -12 | -16 |

(b)

| | | | | | |
|----|----|---|----|----|----|
| × | 1 | 0 | -1 | -2 | -3 |
| -4 | -4 | 0 | 4 | 8 | 12 |
| -2 | -2 | 0 | 2 | 4 | 6 |
| 0 | 0 | 0 | 0 | 0 | 0 |
| 1 | 1 | 0 | -1 | -2 | -3 |

15.2

Answers

4. (a)

| | | | |
|----|----|----|----|
| × | 1 | -1 | 3 |
| 2 | 2 | -2 | 6 |
| -2 | -2 | 2 | -6 |
| -3 | -3 | 3 | -9 |

(b)

| | | | |
|----|----|----|-----|
| × | -2 | -3 | -4 |
| -5 | 10 | 15 | 20 |
| -2 | 4 | 6 | 8 |
| 3 | -6 | -9 | -12 |

5. (a) $(-4) \times 5 = -20$ (b) $(-80) \div (-20) = 4$ (c) $16 \times (-2) = -32$
 (d) $(-4) \times (-8) = 32$ (e) $(-4) \times (-3) = 12$ (f) $40 \div (-5) = -8$
 (g) $(-8) \times (-6) = 48$ (h) $(-32) \div (-8) = 4$ (i) $15 \times (-4) = -60$
 (j) $100 \div (-4) = -25$

6. (a) $-32, 64, -128$ Multiply each term by -2 to get the next term.
 (b) $32, -64, 128$ Multiply each term by -2 to get the next term.
 (c) $10\ 000, -100\ 000, 1\ 000\ 000$ Multiply each term by -10 to get the next term.
 (d) $81, -243, 729$ Multiply each term by -3 to get the next term.
 (e) $-625, 3125, -15\ 625$ Multiply each term by -5 to get the next term.

7.

| | | | | |
|---|---|----|----|----|
| × | 1 | 2 | 3 | 5 |
| 1 | 1 | 2 | 3 | 5 |
| 2 | 2 | 4 | 6 | 10 |
| 3 | 3 | 6 | 9 | 15 |
| 5 | 5 | 10 | 15 | 25 |

| | | | | |
|----|----|----|----|----|
| × | -1 | -2 | -3 | -5 |
| -1 | 1 | 2 | 3 | 5 |
| -2 | 2 | 4 | 6 | 10 |
| -3 | 3 | 6 | 9 | 15 |
| -5 | 5 | 10 | 15 | 25 |

and many other possibilities.

8. (a) 96 (b) -64 (c) 8
 (d) -56 (e) 64 (f) -12
9. (a) -6 (b) 15 (c) -14
 (d) -72 (e) 12 (f) -7

15.3

Answers

10. (a) -2 (b) 6 (c) 6
(d) -12 (e) -62 (f) 16
11. (a) 14 (b) -17 (c) 0 (d) -20

Practice Book *UNIT 16 Algebra: Linear Equations* Answers

16.1 Fundamental Algebraic Skills

1. (a) KCCR KC YR FMKC (b) OVER TO YOU
2. (a) SAZQ RUETUZS (b) HIGH FIVE

3. (a)

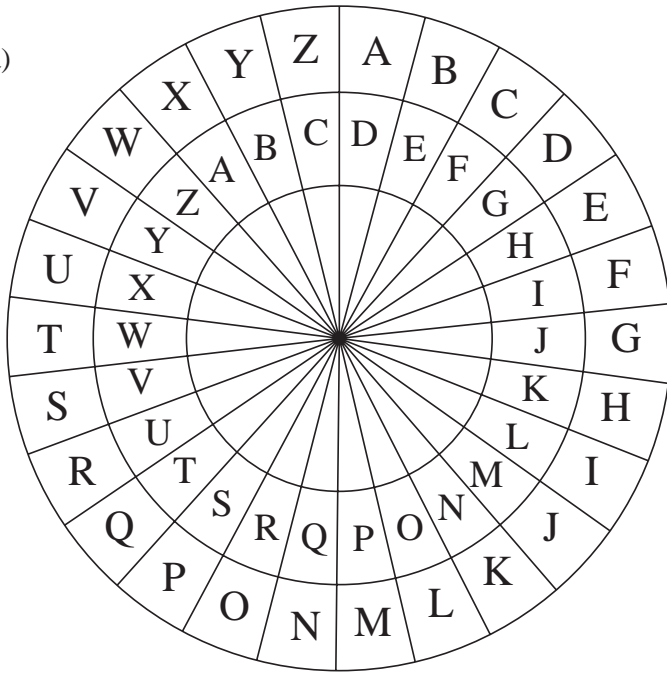

(b) DANGER AHEAD

4. (a) 8 (b) 4 (c) 10
 (d) 9 (e) 8 (f) 6
 (g) 18 (h) 20 (i) 24
 (j) 18 (k) 18 (l) 5
5. (a) 4 (b) -1 (c) -5
 (d) 3 (e) -12 (f) 2
 (g) 6 (h) 0 (i) 13
 (j) -2 (k) 20 (l) 3
6. (a) 24 (b) 8 (c) 18
 (d) 8 (e) 40 (f) 35
 (g) 14 (h) 48 (i) 6
 (j) 91 (k) -4 (l) -6
7. 60

16.1

Answers

8. 6
9. (a) $5a$ (b) $13b$ (c) $2c$ (d) $16d$
(e) $10e$ (f) f (g) 0 (h) $5p + 2h$ (cannot be simplified)
(i) $a + 4b$ (j) $4x + 2y$ (k) $2t + 5s$ (l) $3m + n + 9p + 11q$
10. (a) $a + b + c$ (b) $2a + b$ (c) $a + 2b + c$
(d) $6a$ (e) $5b$ (f) $4a + 4b$
11. $2x + 5$
12. $£2x + 50$
13. Either $50x + 100p$ or $£0.5x + 1$

16.2 Function Machines

1. (a) 10 (b) 30 (c) 3
(d) 7 (e) 7 (f) 500
2. (a) 5 (b) 14 (c) 15
(d) 8 (e) 3 (f) 27
3. (a) 6 (b) 4 (c) 20
(d) 20 (e) 9 (f) 6
4. (a) 2 (b) 17 (c) 7 (d) 6
(e) 48 (f) 69 (g) -2 (h) -5
5. (a) $25\frac{1}{2}$ or 25.5 (b) 7 (c) -3
6. 3
7. 28 years
8. $£13.50$
9. 52 passengers
10. 11 cm

Answers

16.3 Linear Equations

1. (a) $x = 6$ (b) $x = 6$ (c) $x = 8$
 (d) $x = 7$ (e) $x = 9$ (f) $x = 8$
 (g) $x = 24$ (h) $x = 45$ (i) $x = 9$
 (j) $x = -2$ (k) $x = -2$ (l) $x = 18$
 (m) $x = -14$ (n) $x = 0$ (o) $x = 2$

2. (a) $x = 5$ (b) $x = 6$ (c) $x = 5$
 (d) $x = 5$ (e) $x = 7$ (f) $x = 3$
 (g) $x = 7$ (h) $x = 9$ (i) $x = 4$
 (j) $x = -2$ (k) $x = -2$ (l) $x = -6$

3. (a) $x = 1\frac{1}{3}$ (or $\frac{4}{3}$) (b) $x = 1\frac{2}{5}$ (or $\frac{7}{5}$) (c) $x = 2\frac{1}{2}$ (or $\frac{5}{2}$)
 (d) $x = \frac{3}{8}$ (e) $x = 1\frac{1}{2}$ (or $\frac{3}{2}$) (f) $x = 4\frac{1}{4}$ (or $\frac{17}{4}$)

4. $x + 23 = 31$; $x = 8$ cm

5. (a) $2x + 36$ (b) $x = 6$ cm (c) $x = 4\frac{1}{2}$ cm or 4.5 cm

6. (a) $2x - 10 = 8$; Ben's age is 9
 (b) $2x - 10 = 10$; Ian's age is 10; $2x - 10 = 14$; Adam's age is 12
 $2x - 10 = 11$; Sergio's age is $10\frac{1}{2}$

7. $4x + 4 = 9.6$; $x = 1.4$ cm

8. (a) $x = 3$ (b) $x = 3$ (c) $x = 6$
 (d) $x = 3$ (e) $x = 9$ (f) $x = 6$
 (g) $x = 7$ (h) $x = 11$ (i) $x = -5$
 (j) $x = -3$ (k) $x = 10$ (l) $x = -1$

9. (a) $5x + 80 = 180$; $x = 20$ (b) The unknown angles are 60° and 40° .

10. $4x + 40 = 180$; $x = 35$; the unknown angles are 35° and 105° .

11. $3x + 10 = x + 11$; $x = \frac{1}{2}$ (or 0.5)

Practice Book *UNIT 17 Arithmetic: Decimals*

Fractions and Percentages

Answers

17.1 Conversion: Decimals into Fractions

1. (a) $\frac{7}{10}$ or 7 tenths (b) $\frac{7}{100}$ or 7 hundredths (c) 7 units
 (d) $\frac{7}{1000}$ or 7 thousandths (e) $\frac{7}{100}$ or 7 hundredths (f) $\frac{7}{1000}$ or 7 thousandths
2. (a) 0.106, 0.16, 0.601, 0.61, 0.616, 0.661
 (b) 0.28, 0.4, 0.47, 0.78, 0.82
 (c) 0.2, 0.23, 0.3, 0.301, 0.32
 (d) 0.17, 0.19, 0.79, 0.9, 0.91
3. (a) $\frac{1}{10}$ (b) $\frac{9}{10}$ (c) $\frac{3}{10}$ (d) $\frac{7}{100}$
 (e) $\frac{1}{4}$ (f) $\frac{1}{1000}$ (g) $\frac{1}{20}$ (h) $\frac{3}{1000}$
 (i) $\frac{17}{1000}$ (j) $\frac{71}{100}$ (k) $\frac{87}{100}$ (l) $\frac{210}{1000}$
4. (a) $\frac{2}{5}$ (b) $\frac{2}{25}$ (c) $\frac{27}{50}$ (d) $\frac{3}{500}$
 (e) $\frac{3}{250}$ (f) $\frac{81}{500}$ (g) $\frac{6}{125}$ (h) $\frac{21}{25}$
 (i) $\frac{41}{125}$ (j) $\frac{7}{500}$ (k) $\frac{1}{125}$ (l) $\frac{27}{250}$
5. (a) 3 (b) 7 (c) 9
 (d) 1 (e) 3 (f) 2
6. (a) $\frac{6}{5}$ or $1\frac{1}{5}$ (b) $\frac{151}{50}$ (c) $\frac{103}{25}$
 (d) $\frac{181}{50}$ (e) $\frac{501}{125}$ (f) $\frac{1003}{200}$
7. (a) 1.3 or $1\frac{3}{10}$ (b) 0.5 or $\frac{1}{2}$ (c) 1.33 or $1\frac{33}{100}$ (d) 7.9 or $7\frac{9}{10}$
 (e) 0.36 or $\frac{9}{25}$ (f) 1.91 or $1\frac{91}{100}$ (g) 7.86 or $7\frac{43}{50}$ (h) 0.418 or $\frac{209}{500}$

17.1

Answers

8. (a) 0.61 or $\frac{61}{100}$ (b) 00.11 or $\frac{11}{100}$ (c) 0.44 or $\frac{11}{25}$ (d) 0.34 or $\frac{17}{50}$

9. (a) $\frac{1}{10000}$ (b) $\frac{9}{10000}$ (c) $\frac{21}{100000}$ (d) $\frac{123491}{1000000}$

10. (a) $\frac{8}{100000} = \frac{1}{12500}$ (b) $\frac{2222}{100000} = \frac{1111}{50000}$ (c) $\frac{102}{100000} = \frac{51}{50000}$

(d) $\frac{4}{1000000} = \frac{1}{250000}$ (e) $\frac{224}{1000000} = \frac{7}{31250}$ (f) $\frac{2}{10000000} = \frac{1}{5000000}$

17.2 Conversion: Fractions into Decimals

1. (a) 0.3 (b) 0.07 (c) 0.009 (d) 0.13
 (e) 0.131 (f) 0.047 (g) 0.21 (h) 0.183
 (i) 0.19 (j) 0.019 (k) 0.11 (l) 0.81

2. (a) 1 (b) 7 (c) 2 (d) 1
 (e) 50 (f) 500 (g) 25 (h) 25

3. (a) 0.5 (b) 0.8 (c) 0.18 (d) 0.12
 (e) 0.15 (f) 0.006 (g) 0.004 (h) 0.35
 (i) 0.305 (j) 0.72 (k) 0.072 (l) 0.25

4. (a) 1.2 (b) 2.12 (c) 5.218
 (d) 20.08 (e) 2.008 (f) 41.8

5. (a) 3.5 (b) 1.05 (c) 1.65
 (d) 1.24 (e) 3.2 (f) 2.002

6. (a) $\frac{3}{5}$ or 0.6 (b) $\frac{3}{8}$ or 0.375 (c) $\frac{25}{4}$ or 6.25
 (d) $\frac{16}{5}$ or 3.2 (e) $\frac{13}{2}$ or 6.5 (f) $\frac{15}{4}$ or 3.75

7. (a) 0.875 (b) 0.875

8. (a) 8.2 (b) 8.2

9. 0.125

10. 0.8125

Answers

17.3 Introduction to Percentages

1. (a) 47% (b) 36% (c) 28%
 (d) 30% (e) 80% (f) 75%

2. (a) 53% (b) 64% (c) 72%
 (d) 70% (e) 20% (f) 25%

3. 24%

4. For example:

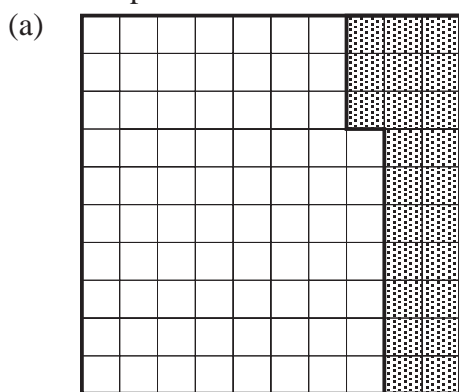

23% shaded

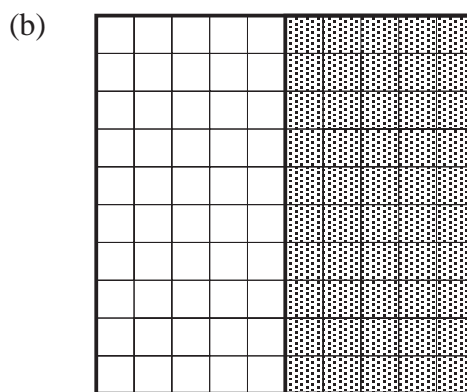

50% shaded

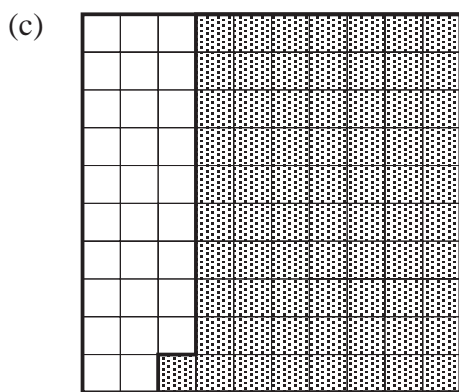

79% shaded

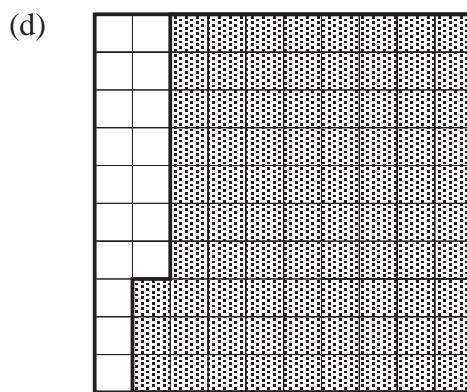

87% shaded

5. For example:

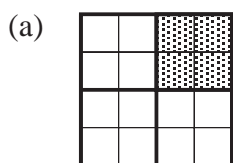

25% shaded

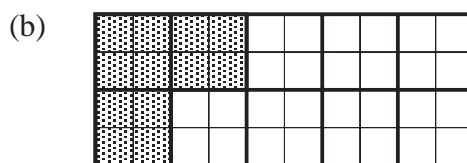

30% shaded

17.3

Answers

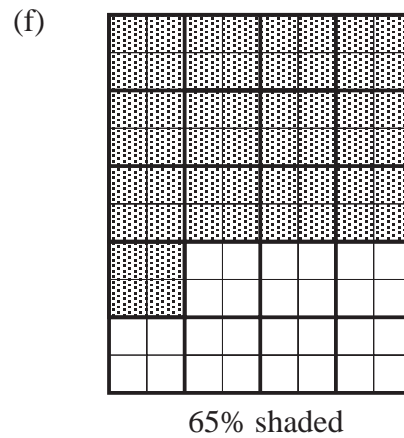
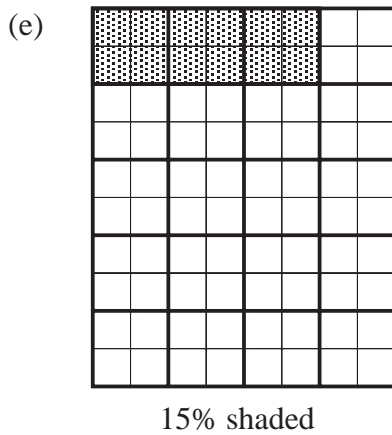
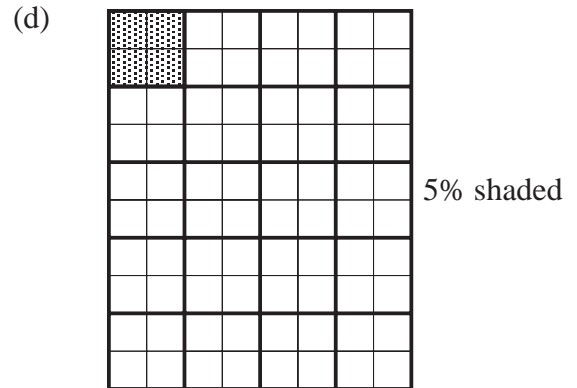
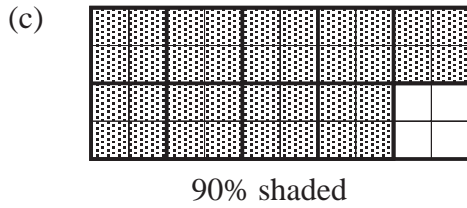

6. (a) 90% (b) 70% (c) 55% (d) 95%
 (e) 80% (f) 60% (g) 75%
7. 65%
8. 12%
9. (a) £100 (b) 150 kg (c) 30p (d) 10p (e) 1.5 kg
 (f) 30 m (g) £8 (h) 52p (i) £60 (j) 150 kg
10. (a) 40% (b) Adam: £15; Ben: £10 (c) Adam: £18; Ben: £12

17.4 Decimals, Fractions and Percentages

1. (a) 0.42 (b) 0.37 (c) 0.2 (d) 0.05 (e) 0.08
 (f) 0.1 (g) 0.22 (h) 0.03 (i) 0.15
2. (a) 14% (b) 72% (c) 55% (d) 40% (e) 3%
 (f) 90% (g) 18% (h) 4% (i) 70%

17.4

Answers

3. (a) $\frac{1}{2}$ (b) $\frac{3}{10}$ (c) $\frac{4}{5}$ (d) $\frac{7}{10}$ (e) $\frac{3}{20}$
 (f) $\frac{1}{4}$ (g) $\frac{16}{25}$ (h) $\frac{49}{50}$ (i) $\frac{14}{25}$

4. (a) 7% (b) 18% (c) 6%
 (d) 34% (e) 15% (f) 28%
 (g) 60% (h) 70% (i) 75%
 (j) 5% (k) 50% (l) 12%

5.

| <i>Fraction</i> | <i>Decimal</i> | <i>Percentage</i> |
|-----------------|----------------|-------------------|
| $\frac{1}{25}$ | 0.04 | 4% |
| $\frac{1}{10}$ | 0.1 | 10% |
| $\frac{1}{2}$ | 0.5 | 50% |
| $\frac{9}{20}$ | 0.45 | 45% |
| $\frac{7}{50}$ | 0.14 | 14% |
| $\frac{21}{25}$ | 0.84 | 84% |

6. (a) $\frac{124}{200}$ or $\frac{31}{50}$ (b) 62% (c) 38%

7. 10%

8. (a) 75% (b) 10% (c) 15%

9. (a) 24% (b) $\frac{24}{100}$ or $\frac{6}{25}$

10. (a) 35% (b) 25% (c) 75%

- (d) $\frac{4}{10}$ or $\frac{2}{5}$ (e) $\frac{1}{4}$ (f) $\frac{3}{4}$

Practice Book *UNIT 18 Quantitative Data*

Answers

18.1 Presentation

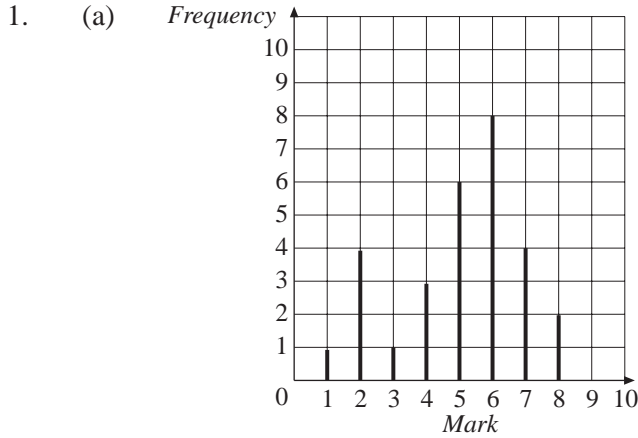

(b) 6

(c) 29

2. (a)

| Size | Tally | Frequency |
|------|-------|-----------|
| 1 | | 1 |
| 2 | | 1 |
| 3 | | 4 |
| 4 | | 5 |
| 5 | | 5 |
| 6 | | 11 |
| 7 | | 7 |
| 8 | | 9 |
| 9 | | 4 |
| 10 | | 1 |
| 11 | | 2 |

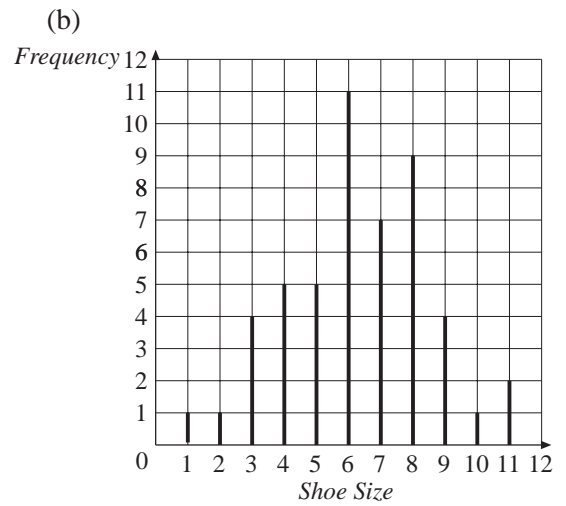

(c) Maintain larger stocks of shoes in sizes 6 – 8; small stock of sizes 1 and 2, 10 and 11.

3. (a) 2 children per family

(b) 28 children

5. (a)

| Score | Frequency |
|-------|-----------|
| 0 | 3 |
| 1 | 5 |
| 2 | 3 |
| 3 | 2 |
| 4 | 1 |
| 5 | 3 |
| 6 | 3 |
| 7 | 1 |
| 8 | 1 |
| 9 | 3 |
| 10 | 3 |

| Score | Frequency |
|-------|-----------|
| 0 | 0 |
| 1 | 0 |
| 2 | 0 |
| 3 | 2 |
| 4 | 5 |
| 5 | 7 |
| 6 | 8 |
| 7 | 5 |
| 8 | 2 |
| 9 | 0 |
| 10 | 0 |

Mr Graddon's Class

Mr Hall's Class

18.1

Answers

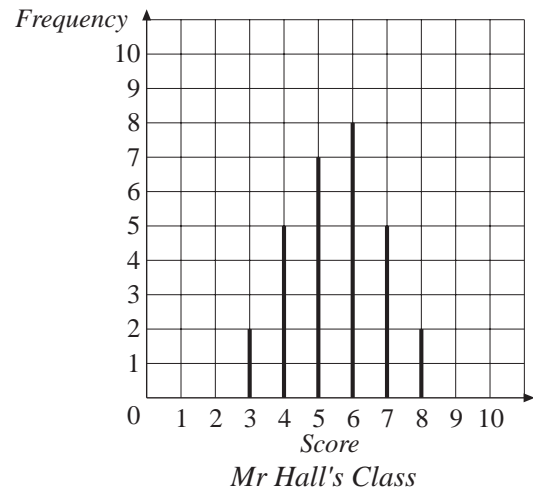
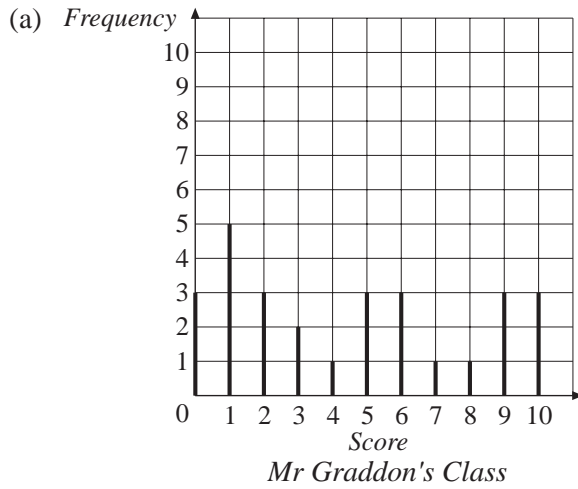

- (b) More pupils scored high marks (9 or 10).
- (c) Closer bunching round the middle mark, and none scoring low (0, 1 or 2).
- (d) Mr Hall's – though no high marks, none with low marks either.

6. (a)

| <i>No. of Tomatoes</i> | <i>No. of Days Frequency</i> |
|------------------------|------------------------------|
| 0 | 0 |
| 1 | 0 |
| 2 | 0 |
| 3 | 1 |
| 4 | 2 |
| 5 | 1 |
| 6 | 3 |
| 7 | 5 |
| 8 | 3 |
| 9 | 5 |
| 10 | 4 |
| 11 | 2 |
| 12 | 1 |
| 13 | 2 |
| 14 | 1 |

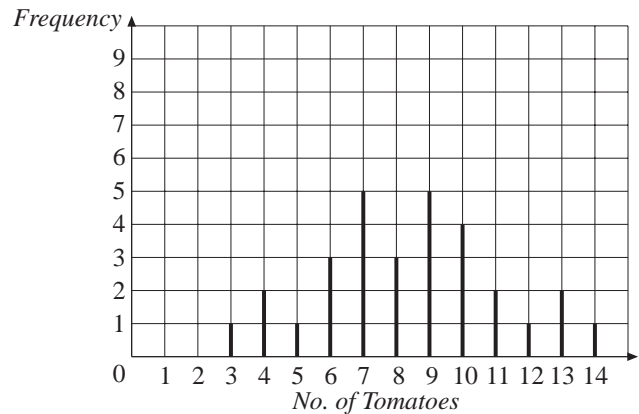

- (b) 14
- (c) 3
- (d) 7 and 9

7. (a)

| <i>No. of Pets</i> | <i>No. of Children (Frequency)</i> |
|--------------------|------------------------------------|
| 0 | 6 |
| 1 | 7 |
| 2 | 2 |
| 3 | 2 |
| 4 | 2 |
| 5 | 1 |

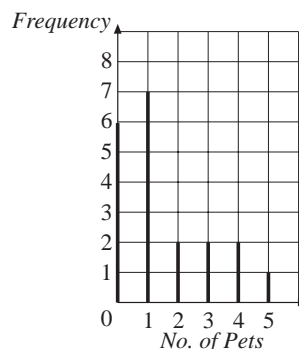

- (b) 30 pets
- (c) 14
- (d) Yes – only 6 do not own pets

18.1

Answers

8. (a)

| <i>No. of Trains Late</i> | <i>Frequency January</i> | <i>Frequency February</i> |
|---------------------------|--------------------------|---------------------------|
| 0 | 10 | 8 |
| 1 | 9 | 9 |
| 2 | 5 | 7 |
| 3 | 5 | 2 |
| 4 | 1 | 1 |
| 5 | 0 | 0 |
| 6 | 1 | 0 |
| 7 | 0 | 1 |

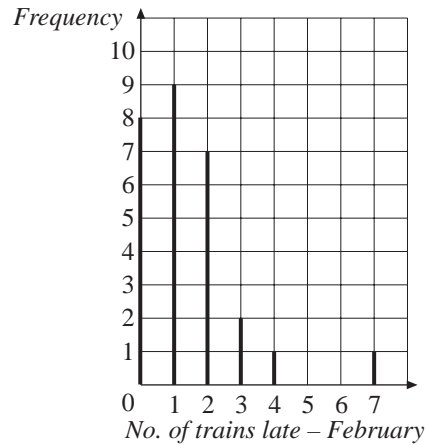
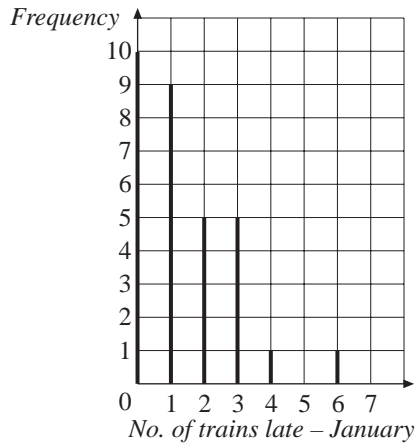

(b) Depends on criteria –

- (i) If 0 trains late – then January
- (ii) If 0 or 1 trains late – then January
- (iii) If 0, 1 or 2 trains late – then February

9. (a)

| <i>No. of Tickets</i> | <i>Frequency</i> |
|-----------------------|------------------|
| 0 | 3 |
| 1 | 2 |
| 2 | 0 |
| 3 | 3 |
| 4 | 3 |
| 5 | 3 |
| 6 | 2 |
| 7 | 2 |
| 8 | 1 |
| 9 | 0 |
| 10 | 0 |
| 11 | 0 |
| 12 | 1 |

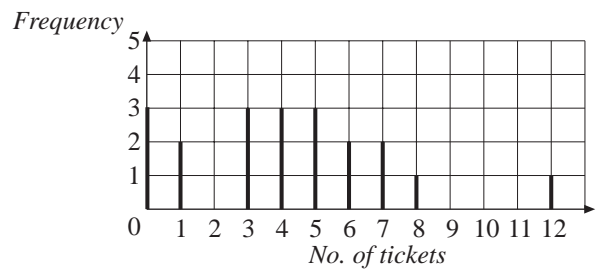

(b) Minimum of 12 tickets in case she has a 'good' day!

18.1

Answers

10. (a)

| <i>No. Generated</i> | <i>Frequency</i> |
|----------------------|------------------|
| 0 | 6 |
| 1 | 3 |
| 2 | 6 |
| 3 | 4 |
| 4 | 2 |
| 5 | 2 |
| 6 | 1 |
| 7 | 4 |
| 8 | 2 |
| 9 | 10 |

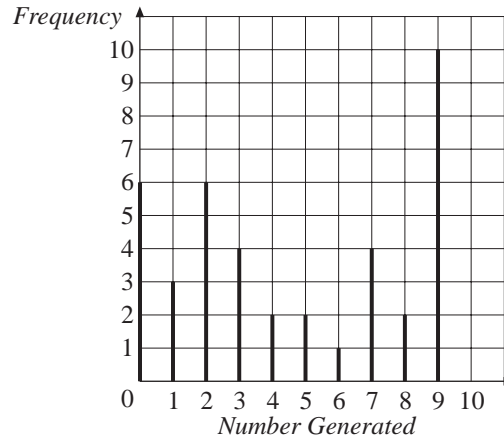

(b) Apparently not random (would expect 4 of each), but the sample is small.

18.2 Measures of Central Tendency

1. (a) Mean: 5.4; Median: 5 Mode: 4

(b) Mean: 6.4; Median: 7 Mode: 7

(c) Mean: 5; Median: 4.5 Mode: 3

(d) Mean: 6.3̇; Median: 7 Mode: 7

2. (a) Mean = 7.25; Median = 7.5 Mode = 8

(b) Mode

3. Mean = £5.88; Median = £4.50; Mode = £4

(a) Mean (b) Mode

4. (a) Mean (b) Median would have been integer (or integer + 0.5); Mode would have been integer.

(c) No – reason as above.

5. $6 \times 9 = 54$; $10 + 12 + 7 + 6 + 9 = 44$. 6th number = $54 - 44 = 10$

6. (a) Mean = 4.75; Median = 4.5; Mode = 5

(b) Mode – highest figure (c) Median – lowest figure

7. (a) Mean = 5.8; Median = 1; Mode = 0

(b) Mean – seeming to indicate greater number of late arrivals.

(c) Train operators – most common occurrence is train on time.

18.2

Answers

8. (a) Type A Mean: $3\frac{1}{7}$; Median: 4 Mode: 5
 Type B Mean: $4\frac{6}{7}$; Median: 3 Mode: 3
- (b) Type A best plant because mode = 5 (as opposed to Type B = 3)
- (c) Type B best plant because mean = $4\frac{6}{7}$ (as opposed to Type A = $3\frac{1}{7}$)
9. (a) 'Height' is continuous data, so no two heights will actually be exactly the same.
 (b) Mean = 151.13 cm (2 d.p.); Median = 157.5 cm
 (c) Mean dragged down by the low heights of 112 cm and 142 cm.
10. Mode = 1; Mean = 2.5 Median = 1.5
- Sum of numbers = 4×2.5 Median = $\frac{1+2}{2}$
 = 10 = 1.5
- Therefore set consists of 1, 1, 2, 6

18.3 Measures of Dispersion

1. (a) $12 - 3 = 9$ (b) $42 - 5 = 37$ (c) $6 - 0 = 6$ (d) $11 - 3 = 8$
2. $8 - 2 = 6$
3. $5 + 12 = 17$
4. $86 - 47 = 39$
5. $182 - 143 = 39$ cm
6. (a) $85 - 10 = 75$ p (b) $90 + 10 = 100$ p (c) $10 + 150 = 160$ p
 (d) 'Equal to' would mean value lay *within* 85p to 10p.
 'Greater than' would mean value lay *outside* 85p to 10p.
7. (a) Missing number = 2 or 10 (b) Missing number = 0 or 12
 (c) Missing number must be between 3 and 9 inclusive
8. 10 °C
9. -2 °C
10. -4 °C

Answers

18.4 Comparing Data

1. (a) Set A Mean: 5 Range: 10 (b) Set B more tightly bunched.
Set B Mean: 5 Range: 4
2. (a) Set A Mean: 6 Range: 4 (b) Set B has greater mean.
Set B Mean: 7 Range: 4
3. (a) Set A Mean: 5 Range: 8 (b) Greater range in set A.
Set B Mean: 6.5 Range: 6 Higher mean in set B.
4. (a) Set A Mean: 6 Range: 4 (b) Set B greatest range; set C the smallest.
Set B Mean: 5.2 Range: 12 Set C the greatest mean; set B the smallest.
Set C Mean: 8.7 Range: 2
5. (a) Roy: 1 Frank: 6
(b) Roy: 12 Frank: 7
(c) Roy: 168 Frank: 162
(d) Roy sold more, but Frank's consistency would be better for the business.
6. (a) AG Mean: $1\frac{7}{12} \approx 1.58$ Range: 4 (b) AG more inconsistent than AS.
AS Mean: $1\frac{8}{12} \approx 1.67$ Range: 3 (c) AS more likely to score on a weekly basis.
7. (a) Miss S Mean: 5 Range: 10 (b) Mr Berry's class more consistent in their spelling.
Mr B Mean: 5 Range: 6
8. (a) February Mean: 3.11 (2 d.p.) Median: 2.5 Mode: 0
July Mean: 2.32 (2 d.p.) Median: 2 Mode: 1
(b) February Range: 10; July Range: 9
(c) Although the mean number of buses late decreased, the mode increased. The difference in weather conditions could account for apparent improvements.

Answers

18.5 Trends

1. (a) *1st moving average* $= \frac{4 + 3 + 5}{3}$ (b) Moving averages the same.
 $= 4$

2nd moving average $= \frac{3 + 5 + 4}{3}$
 $= 4$

3rd moving average $= \frac{5 + 4 + 3}{3}$
 $= 4$

4th moving average $= \frac{4 + 3 + 5}{3}$
 $= 4$

2. (a) *1st moving average* $= \frac{6 + 2 + 7 + 1}{4}$
 $= 4$

2nd moving average $= \frac{2 + 7 + 1 + 8}{4}$
 $= 4.5$

3rd moving average $= \frac{7 + 1 + 8 + 4}{4}$
 $= 5$

4th moving average $= \frac{1 + 8 + 4 + 9}{4}$
 $= 5.5$

5th moving average $= \frac{8 + 4 + 9 + 3}{4}$
 $= 6$

6th moving average $= \frac{4 + 9 + 3 + 10}{4}$
 $= 6.5$

(b) Moving average increasing by 0.5 each time.

(c) 7th moving average = 7.0 8th moving average = 7.5

Therefore, 10th value $= (4 \times 7) - (10 + 3 + 9)$ 11th value $= (4 \times 7.5) - (6 + 10 + 3)$
 $= 28 - 22$ $= 30 - 19$
 $= 6$ $= 11$

18.5

Answers

3. (a) *1st moving average* $= \frac{16 + 7 + 20 + 5}{4}$
 $= 12$

2nd moving average $= \frac{7 + 20 + 5 + 14.2}{4}$
 $= 11.55$

3rd moving average $= \frac{20 + 5 + 14.2 + 7.2}{4}$
 $= 11.6$

4th moving average $= \frac{5 + 14.2 + 7.2 + 19.2}{4}$
 $= 11.4$

5th moving average $= \frac{14.2 + 7.2 + 19.2 + 4.2}{4}$
 $= 11.2$

(b) The mean difference $= \frac{-0.45 + 0.05 - 0.2 - 0.2}{4}$
 $= \frac{-0.8}{4}$
 $= -0.2$

6th moving average $= 11.2 - 0.2$
 $= 11$

7th moving average $= 11 - 0.2$
 $= 10.8$

9th value $= (11 \times 4) - (4.2 + 19.2 + 7.2)$
 $= 44 - 30.6$
 $= 13.4$

10th value $= (10.8 \times 4) - (13.4 + 4.2 + 19.2)$
 $= 43.2 - 36.8$
 $= 6.4$

4. (a) *1st moving average* $= \frac{4 + 6 + 5}{3}$
 $= 5$

2nd moving average $= \frac{6 + 5 + 5.5}{3}$
 $= 5.5$

18.5

Answers

$$\begin{aligned} 3\text{rd moving average} &= \frac{5 + 5.5 + 7.5}{3} \\ &= 6 \end{aligned}$$

$$\begin{aligned} 4\text{th moving average} &= \frac{5.5 + 7.5 + 6.5}{3} \\ &= 6.5 \end{aligned}$$

Moving average increasing by 0.5 each time.

$$5\text{th moving average} = 7.0 \quad 7\text{th value} = 7.0 \times 3 - 6.5 - 7.5 = 7$$

$$6\text{th moving average} = 7.5 \quad 8\text{th value} = 7.5 \times 3 - 7 - 6.5 = 9$$

$$\begin{aligned} 5. \quad (a) \quad \text{In reverse:} \quad 5\text{th moving average} &= \frac{4.6 + 4.2 + 6.6 + 6.2}{4} \\ &= 5.4 \end{aligned}$$

$$\begin{aligned} 4\text{th moving average} &= \frac{5.8 + 4.6 + 4.2 + 6.6}{4} \\ &= 5.3 \end{aligned}$$

$$\begin{aligned} 3\text{rd moving average} &= \frac{6.2 + 5.8 + 4.6 + 4.2}{4} \\ &= 5.2 \end{aligned}$$

$$\begin{aligned} 2\text{nd moving average} &= \frac{3.8 + 6.2 + 5.8 + 4.6}{4} \\ &= 5.1 \end{aligned}$$

$$\begin{aligned} (b) \quad 1\text{st moving average} &= \frac{x + 3.8 + 6.2 + 5.8}{4} \\ &= 5.0 \end{aligned}$$

$$x = 5 \times 4 - 15.8$$

$$= 4.2$$

$$\begin{aligned} 6. \quad (a) \quad 1\text{st moving average} &= \frac{3.6 + 9.7 + 3.2 + 4.1}{4} \\ &= 5.15 \end{aligned}$$

$$\begin{aligned} 2\text{nd moving average} &= \frac{9.7 + 3.2 + 4.1 + 3.6}{4} \\ &= 5.15 \end{aligned}$$

$$\begin{aligned} 3\text{rd moving average} &= \frac{3.2 + 4.1 + 3.6 + 9.8}{4} \\ &= 5.175 \end{aligned}$$

18.5

Answers

$$\begin{aligned} 4\text{th moving average} &= \frac{4.1 + 3.6 + 9.8 + 3.4}{4} \\ &= 5.225 \end{aligned}$$

$$\begin{aligned} 5\text{th moving average} &= \frac{3.6 + 9.8 + 3.4 + 4.4}{4} \\ &= 5.3 \end{aligned}$$

$$\begin{aligned} \text{Mean difference} &= \frac{0 + 0.025 + 0.05 + 0.075}{4} \\ &= 0.0375 \end{aligned}$$

$$6\text{th moving average} = 5.3375$$

$$7\text{th moving average} = 5.375$$

$$8\text{th moving average} = 5.4125$$

$$9\text{th moving average} = 5.45$$

$$\text{Spring 1998} = 5.3375 \times 4 - 4.4 - 3.4 - 9.8 = 3.75$$

$$\text{Summer 1998} = 5.375 \times 4 - 3.75 - 4.4 - 3.4 = 9.95$$

$$\text{Autumn 1998} = 5.4125 \times 4 - 9.95 - 3.75 - 4.4 = 3.55$$

$$\text{Winter 1998} = 5.45 \times 4 - 3.55 - 9.95 - 3.75 = 4.55$$

$$\begin{aligned} 7. \quad (a) \quad 1\text{st moving average} &= \frac{58 + 62 + 74 + 81}{4} \\ &= 68.75 \end{aligned}$$

$$\begin{aligned} 2\text{nd moving average} &= \frac{62 + 74 + 81 + 67}{4} \\ &= 71 \end{aligned}$$

$$\begin{aligned} 3\text{rd moving average} &= \frac{74 + 81 + 67 + 70}{4} \\ &= 73 \end{aligned}$$

$$\begin{aligned} 4\text{th moving average} &= \frac{81 + 67 + 70 + 81}{4} \\ &= 74.75 \end{aligned}$$

$$\begin{aligned} 5\text{th moving average} &= \frac{67 + 70 + 81 + 89}{4} \\ &= 76.75 \end{aligned}$$

18.5

Answers

$$\begin{aligned} \text{Mean difference} &= \frac{2.25 + 2 + 1.75 + 2}{4} \\ &= 2 \end{aligned}$$

$$6\text{th moving average} = 78.75$$

$$7\text{th moving average} = 80.75$$

$$9\text{th moving average} = 82.75$$

$$10\text{th moving average} = 84.75$$

$$\text{January 1999} = 78.75 \times 4 - 89 - 81 - 70 = 75$$

$$\text{April 1999} = 80.75 \times 4 - 75 - 89 - 81 = 78$$

$$\text{July 1999} = 82.75 \times 4 - 78 - 75 - 89 = 89$$

$$\text{October 1999} = 84.75 \times 4 - 89 - 78 - 75 = 97$$

$$\begin{aligned} 8. \quad (a) \quad 1\text{st moving average} &= \frac{24.1 + 26.3 + 28.4 + 20.4}{4} \\ &= 24.8 \end{aligned}$$

$$2\text{nd moving average} = 26.1$$

$$3\text{rd moving average} = 27.5$$

$$4\text{th moving average} = 29.2$$

$$5\text{th moving average} = 31.2$$

$$\begin{aligned} \text{Mean difference} &= \frac{1.4 + 1.7 + 1.3 + 2}{4} \\ &= 1.6 \end{aligned}$$

$$6\text{th moving average} = 32.8$$

$$7\text{th moving average} = 34.4$$

$$8\text{th moving average} = 36$$

$$9\text{th moving average} = 37.6$$

$$\text{Preceding averages} \quad 0\text{th} = 23.2$$

$$- 1\text{st} = 21.6$$

$$- 2\text{nd} = 20.0$$

$$- 3\text{rd} = 18.4$$

$$\begin{aligned} 1\text{st 1999} &= 32.8 \times 4 - 28.4 - 35.2 - 31.9 \\ &= 35.7 \end{aligned}$$

$$\begin{aligned} 2\text{nd 1999} &= 34.4 \times 4 - 35.7 - 28.4 - 35.2 \\ &= 38.3 \end{aligned}$$

$$\begin{aligned} 3\text{rd 1999} &= 36 \times 4 - 38.3 - 35.7 - 28.4 \\ &= 41.6 \end{aligned}$$

$$\begin{aligned} 4\text{th 1999} &= 37.6 \times 4 - 41.6 - 38.3 - 35.7 \\ &= 34.8 \end{aligned}$$

$$\begin{aligned} 4\text{th 1996} &= 23.2 \times 4 - 28.4 - 26.3 - 24.1 \\ &= 14 \end{aligned}$$

$$\begin{aligned} 3\text{rd 1996} &= 21.6 \times 4 - 26.3 - 24.1 - 14 \\ &= 22 \end{aligned}$$

$$\begin{aligned} 2\text{nd 1996} &= 20 \times 4 - 24.1 - 14 - 22 \\ &= 19.9 \end{aligned}$$

$$\begin{aligned} 1\text{st 1996} &= 18.4 \times 4 - 19.9 - 22 - 14 \\ &= 17.7 \end{aligned}$$

18.5

Answers

9. *1st moving average* = $\frac{18 + 22 + 9 + 7 + 15}{5}$ = 14.2
- 2nd moving average* = = 14.4
- 3rd moving average* = = 14.6
- 4th moving average* = = 14.6
- 5th moving average* = = 16.8
- 6th moving average* = = 15
- 7th moving average* = = 15.4
- 8th moving average* = = 15.4
- 9th moving average* = = 15.6
- 10th moving average* = = 16
- 11th moving average* = = 16
- Mean difference = $\frac{0.2 + 0.2 + 0 + 2.2 - 1.8 + 0.4 + 0 + 0.2 + 0.4 + 0}{11}$
- = $\frac{1.6}{11}$
- = 0.164
- 12th moving average* = = 16.164
- 13th moving average* = = 16.328
- 14th moving average* = = 16.492
- 15th moving average* = = 16.656
- 16th moving average* = = 16.819
- Week 4 Mon = $16.164 \times 5 - 16 - 10 - 10 - 23 \approx 22$ cans
- Tues = $16.328 \times 5 - 22 - 16 - 10 - 10 \approx 24$ cans
- Wed = $16.492 \times 5 - 24 - 22 - 16 - 10 \approx 10$ cans
- Thurs = $16.656 \times 5 - 10 - 24 - 22 - 16 \approx 11$ cans
- Fri = $16.819 \times 5 - 11 - 10 - 24 - 22 \approx 17$ cans
10. *1st moving average (4 pt)* = $\frac{5.3 + 4.4 + 5.4 + 7.3}{4}$ = 5.6
- 2nd* = = 5.925
- 3rd* = = 6.225
- 4th* = = 6.5
- 5th* = = 6.75

18.5

Answers

$$\begin{aligned}\text{Mean difference} &= \frac{0.325 + 0.3 + 0.275 + 0.25}{4} \\ &= 0.2875\end{aligned}$$

$$6\text{th moving average} = 7.0375$$

$$7\text{th moving average} = 7.325$$

$$8\text{th moving average} = 7.6125$$

$$9\text{th moving average} = 7.9$$

$$\text{Spring 1999} = 7.75$$

$$\text{Summer 1999} = 6.75$$

$$\text{Autumn 1999} = 7.65$$

$$\text{Winter 1999} = 9.45$$

Practice Book *UNIT 19 Scale Drawing*

Answers

19.1 Measuring Lengths

1. (a) km (b) m (c) cm (d) cm or mm (e) cm or mm
3. (a) F (b) F (c) T (d) F (e) T (f) F
4. Upper bound = 10.5 cm; Lower bound = 9.5 cm
5. 15.5 cm
6. (a) Upper bound = 1750 km; Lower bound = 1650 km
 (b) Upper bound = 1705 km; Lower bound = 1695 km
7. (a) Yes (b) No (c) Yes (d) No
8. (b) (i) 10 cm (ii) 3 cm (iii) 3 cm or 4 cm
 (iv) 7 cm (v) 8 cm (vi) 10 cm
9. (b) (i) 39° (ii) 154° (iii) 55° (iv) 270°
10. (a) 33°, 42°, 105°
 (b) Yes (33° + 42° + 105° = 180°)

19.2 Plans

1. (a) 8 m (b) 5.5 m (c) 3 m × 1.5 m (d) 2.5 m × 1.5 m
2. 4 m, 3 m, 1 m, 2 m, 3 m, 5 m
3. (a) 3 cm × 8 cm
 (b) 1.5 cm × 4 cm
 (c) 6 cm × 16 cm
 (d) 30 cm × 80 cm
 (e) 15 cm × 40 cm
4. 1.25 m × 1.8 m
5. (a) Plan opposite
 (b) 2.2 to 2.3 cm, which is between 1.1 m and 1.15 m.
6. 1 : 20
7. (a) 4.8 m × 6 m (b) 28.8 m² (c) 7.7 m (1 d.p.)

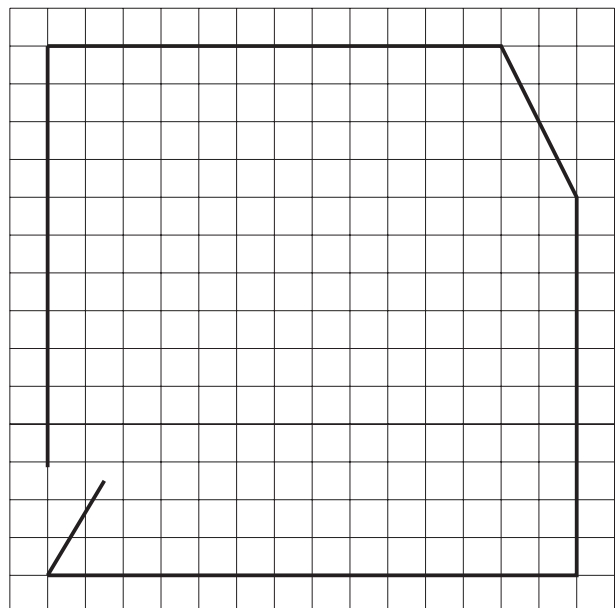

19.2

Answers

8. (a) 40 m (b) 84 m^2 (c) 14.4 m (1 d.p.)
9. (a) 3.6 m (b) $3 \times 1.8 = 5.4 \text{ m}^2$ (c) 20.52 m^2 (d) 5.04 m^2
10. (a) 4 m^2 (b) 2 m (c) 1 : 400

19.3 Maps

1. (a) 24 km (b) 24 km (c) 6.9 km (d) 32.1 km
2. about 4.4 km
3. (a) 2 km (b) 5 km (c) 1.6 km (d) 2.55 km
4. 2.4 km
5. 540 km
6. 5 cm
7. (a) 8 cm (b) 20 cm (c) about 5.4 km
8. (a) 33 cm (b) 16.5 cm (c) 55 cm (d) 150 cm
9. (a)

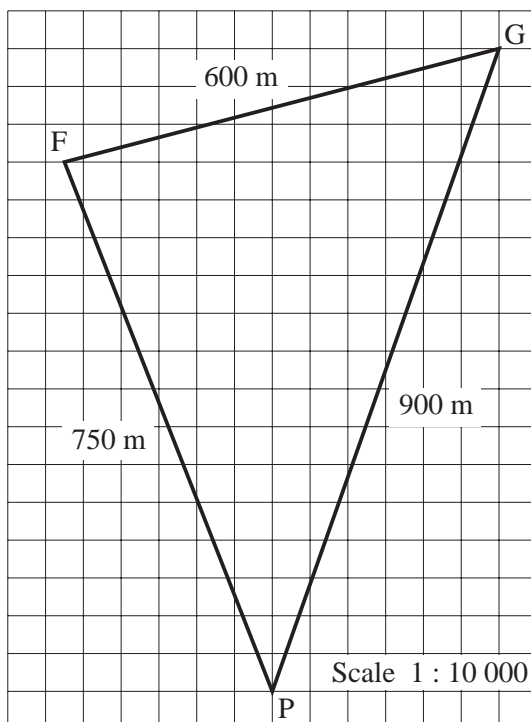

- (b) 510 m
(c) 55°

19.3

Answers

10. $32 \text{ cm} : 40 \text{ km} \rightarrow \text{scale } 1 : 125\,000$

Therefore, 14 cm on the map would represent a distance of 17.5 km.

11. $\text{Area} = 3 \text{ km} \times 2.1 \text{ km}$

$$= 6.3 \text{ km}^2$$

Practice Book *UNIT 20 Arithmetic: Fractions*

Answers

20.1 Revision: Whole Numbers and Decimals

1. (a) 239 (b) 200 (c) 1901 (d) 7.9 (e) 20.1 (f) 7.91
(g) 1.46 (h) 17.61 (i) 0.213 (j) 42.7 (k) 3.51 (l) 14.41
2. (a) 121 (b) 252 (c) 512 (d) 0.7 (e) 1.5 (f) 1.19
(g) 0.69 (h) 7.78 (i) 1.55 (j) 24.3 (k) 45.1 (l) 0.19
3. (a) 54 (b) 210 (c) 441 (d) 180 (e) 364 (f) 897
(g) 3.5 (h) 11.4 (i) 12.87 (j) 5.22 (k) 9.1 (l) 2.272
4. (a) 234 (b) 289 (c) 29 (d) 69 (e) 26 (f) 327
(g) 1.71 (h) 2.1 (i) 1.32
5. 35
6. £2.04
7. £124.80
8. 126 tickets
9. 1 m 60 cm or 160 cm or 1.6 m
10. (a) 7 footballs (b) £2.00

20.2 Addition and Subtraction of Fractions

1. (a) $\frac{4}{7}$ (b) $\frac{4}{8} = \frac{1}{2}$ (c) $\frac{8}{9}$ (d) $\frac{10}{10} = 1$ (e) $\frac{4}{5}$
(f) $\frac{6}{7}$ (g) $\frac{4}{4} = 1$ (h) $\frac{2}{8} = \frac{1}{4}$ (i) $\frac{2}{9}$ (j) $\frac{2}{10} = \frac{1}{5}$
(k) $\frac{5}{11}$ (l) $\frac{2}{15}$ (m) $\frac{3}{13}$ (n) $\frac{1}{7}$ (o) $\frac{4}{25}$
2. (a) $\frac{5}{10} + \frac{2}{10} = \frac{7}{10}$ (b) $\frac{12}{15} + \frac{10}{15} = \frac{22}{15}$ (c) $\frac{5}{30} + \frac{24}{30} = \frac{29}{30}$
(d) $\frac{12}{21} - \frac{7}{21} = \frac{5}{21}$ (e) $\frac{5}{6} - \frac{4}{6} = \frac{1}{6}$
3. (a) $\frac{5}{6}$ (b) $\frac{17}{12}$ (c) $\frac{9}{20}$ (d) $\frac{19}{15}$ (e) $\frac{7}{8}$

20.2

Answers

- (f) $\frac{3}{6} = \frac{1}{2}$ (g) $\frac{38}{35}$ (h) $\frac{17}{21}$ (i) $\frac{6}{10} = \frac{3}{5}$ (j) $\frac{32}{21}$
- (k) $\frac{4}{12} = \frac{1}{3}$ (l) $\frac{1}{8}$ (m) $\frac{5}{36}$ (n) $\frac{2}{21}$ (o) $\frac{1}{20}$
4. (a) $\frac{8}{12} = \frac{2}{3}$ (b) 8
5. (a) $\frac{27}{20}$ ha (b) $\frac{13}{20}$ ha
6. (a) $\frac{11}{15}$ (b) $\frac{4}{15}$ (c) $\frac{3}{10}$
7. (a) $\frac{1}{10}$ (b) $\frac{7}{30}$
8. (a) $2\frac{5}{6} = \frac{17}{6}$ (b) $4\frac{1}{4}$ or $\frac{17}{4}$ (c) $7\frac{9}{10}$ or $\frac{79}{10}$
- (d) $2\frac{53}{56}$ or $\frac{109}{56}$ (e) $\frac{5}{6}$ (f) $\frac{33}{20}$ or $1\frac{13}{20}$ (g) $\frac{7}{8}$
- (h) $\frac{164}{21}$ or $7\frac{17}{21}$ (i) $\frac{69}{40}$ or $1\frac{29}{40}$ (j) $\frac{97}{20}$ or $4\frac{17}{20}$ (k) $\frac{7}{4}$ or $1\frac{3}{4}$
- (l) $\frac{11}{4}$ or $2\frac{3}{4}$
9. £ $\frac{19}{60}$ million
10. $\frac{89}{40}$ or $2\frac{9}{40}$

20.3 Multiplying Fractions

1. (a) 3 (b) 4 (c) 14 (d) 6 (e) 21 (f) 24
 (g) 15 (h) 15 (i) 10 (j) 44 (k) 8 (l) 15
2. (a) $\frac{1}{6}$ (b) $\frac{1}{4}$ (c) $\frac{1}{12}$ (d) $\frac{1}{2}$ (e) $\frac{12}{35}$ (f) $\frac{9}{32}$
 (g) $\frac{8}{63}$ (h) $\frac{9}{28}$ (i) $\frac{25}{42}$ (j) $\frac{9}{70}$ (k) $\frac{3}{38}$ (l) $\frac{8}{33}$

20.3

Answers

3. (a) $\frac{9}{8}$ (b) 3 (c) $\frac{7}{10}$ (d) $\frac{5}{7}$ (e) $\frac{17}{20}$ (f) $\frac{22}{21}$
 (g) $\frac{27}{10}$ or $2\frac{7}{10}$ (h) $\frac{9}{4}$ or $2\frac{1}{4}$ (i) 2 (j) $\frac{25}{8}$ or $3\frac{1}{8}$
 (k) $\frac{91}{12}$ or $7\frac{7}{12}$ (l) $\frac{11}{4}$
4. (a) $\frac{3}{4}$ m² (b) $\frac{5}{2}$ m² or $2\frac{1}{2}$ m²
5. (a) $1\frac{1}{2}$ kg (b) $4\frac{1}{2}$ kg (c) $7\frac{1}{2}$ kg
6. (a) $\frac{1}{2}$ kg (b) $\frac{1}{4}$ kg
7. (a) £ $\frac{3}{20}$ million (b) £ $\frac{9}{20}$ million
8. (a) $\frac{15}{8}$ m² or $1\frac{7}{8}$ m² (b) $\frac{45}{16}$ m² or $2\frac{13}{16}$ m²
9. $\frac{63}{4}$ cm² or $15\frac{3}{4}$ cm²
10. (a) $\frac{7}{6}$ litres or $1\frac{1}{6}$ litres (b) $\frac{7}{3}$ litres or $2\frac{1}{3}$ litres (c) $\frac{23}{12}$ litres or $1\frac{11}{12}$ litres

20.4 Dividing Fractions

1. (a) $\frac{1}{6}$ (b) $\frac{3}{8}$ (c) $\frac{1}{16}$ (d) $\frac{3}{16}$ (e) $\frac{5}{24}$ (f) $\frac{4}{10} = \frac{2}{5}$
 (g) $\frac{2}{7}$ (h) $\frac{4}{45}$ (i) $\frac{1}{24}$ (j) $\frac{5}{24}$ (k) $\frac{3}{20}$ (l) $\frac{4}{35}$
2. (a) 12 (b) 27 (c) 24 (d) 8 (e) $\frac{15}{2}$ (f) $\frac{16}{3}$
 (g) 56 (h) 7 (i) 21 (j) 9 (k) 18 (l) 143
3. (a) $\frac{3}{2}$ (b) $\frac{3}{4}$ (c) $\frac{9}{8}$ or $1\frac{1}{8}$ (d) $\frac{6}{5}$ or $1\frac{1}{5}$ (e) 6

20.4

Answers

- (f) $\frac{3}{4}$ (g) $\frac{25}{14}$ (h) $\frac{9}{7}$ (i) $\frac{9}{16}$ (j) $\frac{27}{4}$
- (k) $\frac{3}{7}$ (l) $\frac{32}{25}$
4. (a) $\frac{6}{13}$ (b) $\frac{14}{5}$ (c) $\frac{91}{40}$ (d) $\frac{7}{3}$ (e) $\frac{33}{4}$ (f) $\frac{147}{25}$
5. $\frac{1}{4}$ kg
6. $\frac{1}{40}$ litres
7. $\frac{3}{8}$ kg
8. (a) 18 (b) 8
9. (a) 5 cakes (b) 11 cakes (c) 13 cakes
10. (a) 40 miles (b) 60 miles (c) 72 miles

Practice Book *UNIT 21 Probability of One Event* **Answers**

21.1 Introduction to Probability

1. (a) Certain
 (b) Depends on the day of the week and whether the student normally travels to school by bus.
 (c) Depends on the football team and who they are playing.
 (d) Depends on the weather, the time of year and the general punctuality of the student.

2. (a) E (b) A (c) B (d) D



- (b) Depends on the student; it could be 0 for a student who does not have a packed lunch, or close to 0 for a student who brings a packed lunch regularly, but it could be much higher for a student who brings a packed lunch only occasionally.

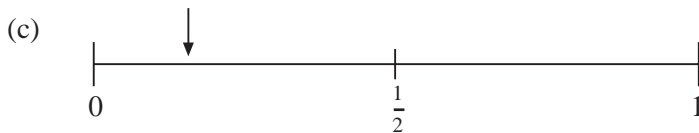

- (d) Depends on the location of the school and the time of year.
 (e) $1 - (\text{answer to (d)})$.

5. (a) A (b) D (c) A and C (d) B, C and D

6. (a) Depends on the time of year this unit is taught.
 (b) $1 - (\text{answer to (a)})$ (or very close to it, for example, if a student is repeating a year).

7. Depends on the student and the level of difficulty of the homework.

8. Depends on the student but should show a decreasing likelihood from A through to E, for example:

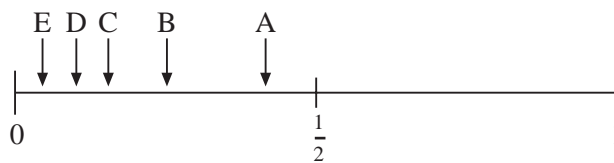

21.2 Calculating the Probability of a Single Event

1. (a) $\frac{1}{2}$ (b) $\frac{1}{6}$ (c) $\frac{1}{3}$ (d) $\frac{2}{3}$ (e) $\frac{1}{3}$ (f) $\frac{1}{2}$
2. (a) $\frac{3}{10}$ (b) $\frac{7}{10}$
3. $\frac{1}{2}$

21.2

Answers

4. (a) $\frac{1}{4}$ (b) $\frac{1}{2}$ (c) $\frac{1}{4}$
5. (a) $\frac{1}{8}$ (b) $\frac{1}{8}$ (c) $\frac{1}{4}$ (d) $\frac{1}{2}$ (e) $\frac{5}{8}$
6. (a) $\frac{1}{2}$ (b) $\frac{3}{8}$ (c) $\frac{1}{8}$ (d) $\frac{1}{2}$ (e) $\frac{5}{8}$
7. (a) $\frac{2}{5}$ (b) $\frac{3}{5}$
8. (a) $\frac{1}{3}$ (b) $\frac{1}{2}$ (c) $\frac{1}{6}$ (d) $\frac{1}{2}$ (e) $\frac{5}{6}$
9. (a) $\frac{3}{16}$ (b) $\frac{3}{32}$ (c) $\frac{7}{32}$
(d) $\frac{1}{16}$ (e) $\frac{25}{32}$ (f) $\frac{7}{8}$
10. 4

21.3 Relative Frequency

3. (d) Should get closer to $\frac{1}{6}$ if the dice is fair.
5. $\frac{2}{5}$
7. (a) $\frac{7}{50}$ (b) $\frac{3}{50}$ (c) $\frac{14}{25}$ (d) $\frac{2}{5}$
8. 10
9. (a) $\frac{3}{10}$
(b) The estimate was based on only a small number of games. It also reflects the teams already played and, in the next match, they may play a stronger or weaker team than those they have played so far.
10. Approximately 0.65 or $\frac{2}{3}$.

21.4 Complementary Events

1. $\frac{2}{5}$
2. $\frac{7}{8}$
3. $\frac{19}{20}$

21.4

Answers

4. 0.9
5. 0.25
6. $\frac{12}{13}$
7. (a) $\frac{1}{3}$ (b) $\frac{2}{3}$
8. (a) $\frac{1}{2}$ (b) $\frac{1}{2}$
9. (a) $\frac{2}{5}$ (b) $\frac{3}{5}$
10. (a) $\frac{33}{100}$ (b) $\frac{67}{100}$

21.5 Estimating the Number of Outcomes

1. (a) 100 (b) 300 (c) 300 (d) 200
2. (a) 40 (b) 80 (c) 80 (d) 120
3. 6
4. 5
5. (a) 2 (b) 8 (c) 40
6. (a) 18 (b) 60
7. (a) 1000 (b) 6 (c) 1
8. (a) 14 (b) 49 (c) 700
9. 13
10. (a) 2, assuming he goes to school 5 days a week.
 (b) Because the expected number of times missed is a long term average; sometimes he might miss the bus 3 times, as here, and other times he might miss it once, twice or not at all.

21.6 Addition Law for Mutually Exclusive Events

1. (a) $\frac{3}{10}$ (b) $\frac{1}{4}$ (c) $\frac{9}{20}$ (d) $\frac{11}{20}$ (e) $\frac{3}{4}$ (f) $\frac{7}{10}$
2. (a) $\frac{1}{5}$ (b) $\frac{2}{5}$ (c) $\frac{2}{5}$ (d) $\frac{4}{5}$ (e) $\frac{3}{5}$ (f) $\frac{3}{5}$
3. (a) $\frac{1}{10}$ (b) $\frac{9}{20}$ (c) $\frac{11}{20}$ (d) $\frac{3}{4}$

21.6

Answers

-
4. (a) $\frac{1}{3}$ (b) $\frac{5}{6}$ (c) $\frac{5}{6}$
5. (a) $\frac{5}{8}$ (b) $\frac{3}{16}$ (c) $\frac{5}{16}$ (d) $\frac{9}{16}$
6. (a) $\frac{3}{8}$ (b) $\frac{1}{4}$ (c) $\frac{3}{8}$ (d) $\frac{3}{8}$
7. (a) $\frac{1}{2}$ (b) $\frac{1}{4}$ (c) $\frac{1}{2}$
8. (a) $\frac{5}{12}$ (b) $\frac{3}{4}$
9. (a) $\frac{3}{10}$ (b) $\frac{7}{15}$ (c) $\frac{8}{15}$ (d) $\frac{7}{10}$
10. (a) $\frac{1}{4}$ (b) $\frac{3}{4}$

21.7 General Addition Law

1. (a) $\frac{6}{11}$ (b) $\frac{3}{11}$ (c) $\frac{2}{11}$ (d) $\frac{7}{11}$
2. (a) $\frac{1}{2}$ (b) $\frac{2}{5}$ (c) $\frac{1}{5}$ (d) $\frac{7}{10}$
3. $\frac{2}{3}$
4. $\frac{1}{2}$
5. $\frac{23}{100}$
6. $\frac{19}{24}$
7. $\frac{1}{2}$
8. $\frac{7}{30}$
9. 0.35
10. 1 occurs twice; 2 occurs twice; 3 occurs once; 4 occurs once.

Practice Book *UNIT 22 Volume*

Answers

22.1 Concept of Volume: the Unit Cube

1. (a) 10 cm^3 (b) 12 cm^3 (c) 12 cm^3 (d) 36 cm^3
2. (a) 3 cm^3 (b) 5 cm^3 (c) 5 cm^3
3. (a) 8 (b) 48 cm^3
4. (a) 20 (b) 80 cm^3
5. (a) 16 (b) 64 cm^3
6. 125 cm^3
7. (a) 27 cm^3 (b) 18 cm^3
8. (a) 60 cm^3 (b) 24 cubes
9. (a) $2; \frac{1}{2} \text{ cm}^3$ (b) $8; \frac{1}{8} \text{ cm}^3$
10. (a) $5\frac{1}{2} \text{ cm}^3$ (b) 7 cm^3

22.2 Volume of a Cube

1. (a) 27 cm^3 (b) 64 cm^3 (c) 15.625 cm^3 (d) 3.375 cm^3
2. (a) $27\,000 \text{ cm}^3$ (b) 0.027 m^3
3. (a) $512\,000 \text{ cm}^3$ (b) 8000 cm^3 (c) 64
4. (a) $\frac{1}{8} \text{ m}^3$ (b) 0.125 m^3 (c) $125\,000 \text{ cm}^3$
5. (a) 1000 cm^3 (b) 0.001 m^3
6. (a) $27\,000 \text{ cm}^3$ (b) 125 cm^3 (c) $26\,875 \text{ cm}^3$
7. $6 \times 4 \times 4 \times 4 = 384 \text{ cm}^3$
8. (a) $6 \times 6^3 = 1296 \text{ cm}^3$ (b) 2160 cm^3
9. (a) 7 cm (b) 49 cm^2 (c) 294 cm^2
10. 729 cm^3

Answers

22.3 Volume of a Cuboid

- (a) 40 cm^3 (b) 63 cm^3 (c) 20 m^3 (d) 96 m^3
- (a) 15 m^3 (b) $15\,000\,000 \text{ cm}^3$
- (a) $30\,000 \text{ cm}^3$ (b) 250 cm^3 (c) 120
- (a) 240 cm^3 (b) 240 cm^3
- (a) $\frac{1}{40} \text{ m}^3$ (b) 0.025 (c) $25\,000 \text{ cm}^3$
- (a) 36 cm^3 ; 24 cm^3 (b) 60 cm^3
- 228 cm^3
- 168 cm^3
- (a) 10 cm (b) 12 cm (c) 2.5 cm
- 39 cm^3

22.4 Capacity

- (a) 2000 cm^3 (b) 5000 cm^3 (c) 500 cm^3
(d) 200 cm^3 (e) 1500 cm^3 (f) 2700 cm^3
- (a) 3 litres (b) 7 litres (c) 10 litres
(d) 0.75 litres (e) 0.25 litres (f) 4.9 litres
- (a) 18 m^3 (b) 18 000 litres
- 5 m^3
- A
- 80 glasses
- (a) B (b) 3720 litres
- (a) 4500 litres (b) 1875 litres (c) 0.8 m
- (a) 15 cans (b) 0.5 litres
- (a) $135\,000 \text{ cm}^3$ or 135 litres (b) $123\,750 \text{ cm}^3$ or 123.75 litres
(c) $11\,250 \text{ cm}^3$ (d) 11.25 litres

Answers

22.5 Density

- (a) 100 grams (b) 2000 grams (c) 500 grams
- (a) 0.015 kg/cm^3 (b) 15 grams/cm^3
- (a) 0.004 grams/cm^3 (b) 120 grams
- (a) 1680 kg (b) 840 kg
- (a) 1.25 grams/cm^3 (b) 0.00125 kg/cm^3
- (a) 0.8 grams/cm^3 (b) 360 grams
- (a) 396 000 grams or 39.6 kg (b) 1250 cm^3
- (a) 1.2 grams/cm^3 (b) 42 kg
- (a) 80 000 kg (b) sea water (c) 1.03 grams/cm^3 (d) 1030 grams
- 25 cm^3

22.6 Volume of a Triangular Prism

- (a) 30 cm^3 (b) 72 cm^3 (c) 24 cm^3 (d) 36 cm^3
- 70 cm^3
- (a) 90 cm^3 (b) 180 cm^3
- A: 80 cm^3 B : 120 cm^3 C : 40 cm^3
- 225 cm^3
- (a) 21 cm^2 (b) 126 cm^3
- Length = 6 cm
- 7 cm
- (a) 30 cm^3 (b) 240 cm^3 (c) 8 (d) Yes
(e) Volume $\times 27$ (f) Volume is increased by cube of line scale factor.
- 120 cm^3

Practice Book *UNIT 1 Mathematical Diagrams*

Answers

1.1 Mileage Charts

1. (a) 72 miles (b) 38 miles (c) 44 miles
 (d) 36 miles (e) 71 miles

2. $44 + 39 + 36 = 119$ miles

3. $84 + 44 + 67 + 100 = 295$ miles

4. (a) 220 km (b) 270 km (c) 215 km
 (d) 146 km (e) 199 km

5. $293 + 293 = 586$ km

6. $293 + 220 + 146 + 140 = 799$ km

7.

| | | | | | | |
|----|------------|------------|------------|------------|------------|------------|
| | JUNCTION 1 | | | | | |
| 1 | | JUNCTION 2 | | | | |
| 5 | 4 | | JUNCTION 3 | | | |
| 9 | 8 | 4 | | JUNCTION 4 | | |
| 13 | 12 | 8 | 4 | | JUNCTION 5 | |
| 23 | 22 | 18 | 14 | 10 | | JUNCTION 6 |
| 25 | 24 | 20 | 16 | 12 | 2 | JUNCTION 7 |

8.

| | | | | | |
|----|------------|----------|-----------|-----------|----------|
| | CARMARTHEN | | | | |
| 23 | | LAMPETER | | | |
| 15 | 23 | | LLANDEILO | | |
| 26 | 20 | 11 | | LLANOVERY | |
| 22 | 16 | 7 | 4 | | LLANWRDA |

9.

| | | | | | |
|----|--------|----------|----------|--------|----------|
| | ALSTON | | | | |
| 19 | | BRAMPTON | | | |
| 27 | 8 | | CARLISLE | | |
| 36 | 17 | 9 | | GRETNA | |
| 36 | 17 | 9 | 4 | | LONGTOWN |
| 20 | 27 | 19 | 28 | 28 | PENRITH |

1.1

Answers

10. (a) London → York = 21 + 47 + 120 + 45 = 233 miles
 Stevenage → York = 47 + 120 + 45 = 212 miles
 Peterborough → York = 120 + 45 = 165 miles
 (b) 233 + 233 = 466 miles

| | | | | |
|--|--------|-----------|--------------|-----------|
| | LONDON | | | |
| | 21 | STEVENAGE | | |
| | 68 | 47 | PETERBOROUGH | |
| | 188 | 167 | 120 | DONCASTER |
| | 233 | 212 | 165 | 45 |
| | | | | YORK |

1.2 Using Flow Charts to Plan Practical Tasks

There are many possible variations to the answers given here.

1.

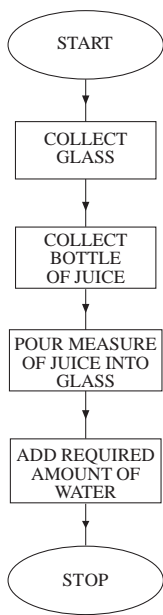

2.

(a)

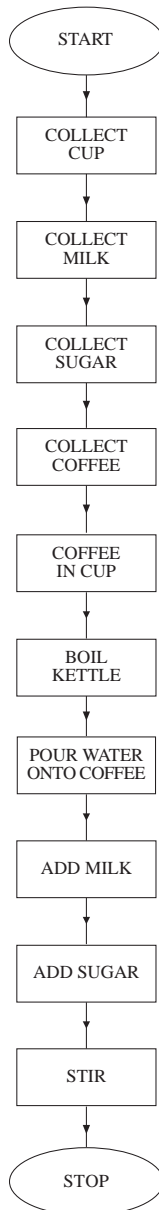

(b)

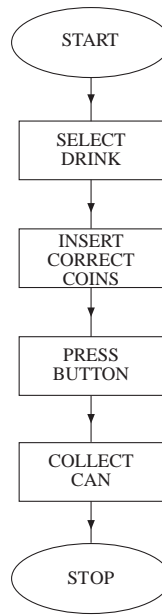

(d)

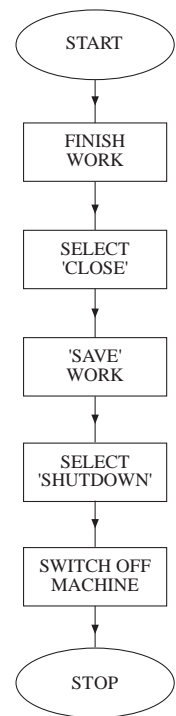

(c)

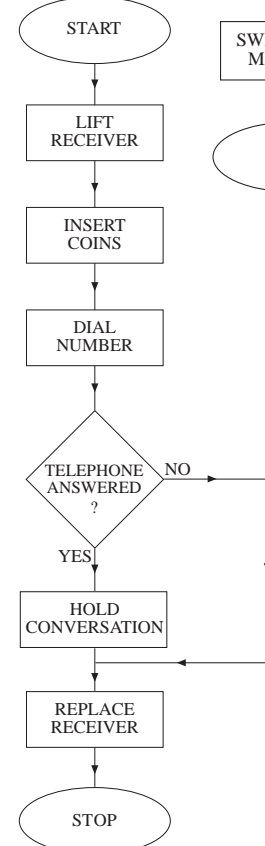

1.2

Answers

3.

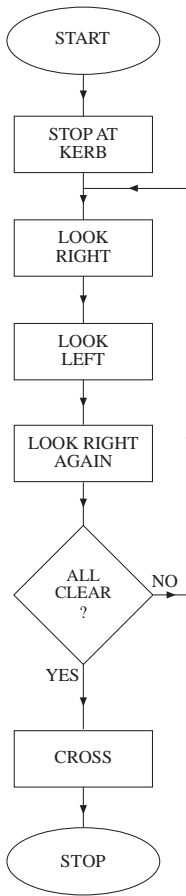

4.

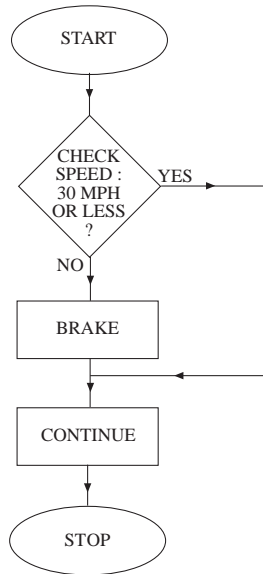

5.

(a)

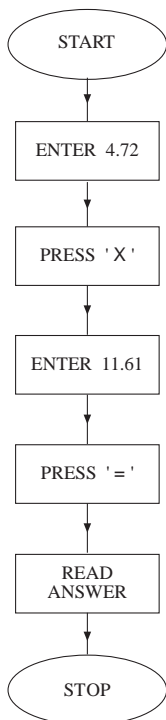

(b)

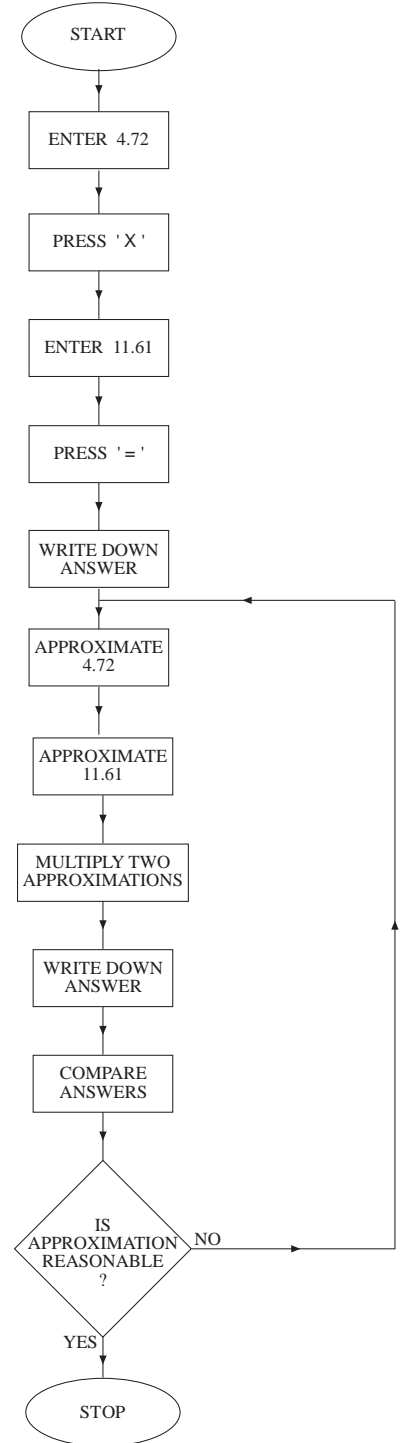

1.2

Answers

6. (a)

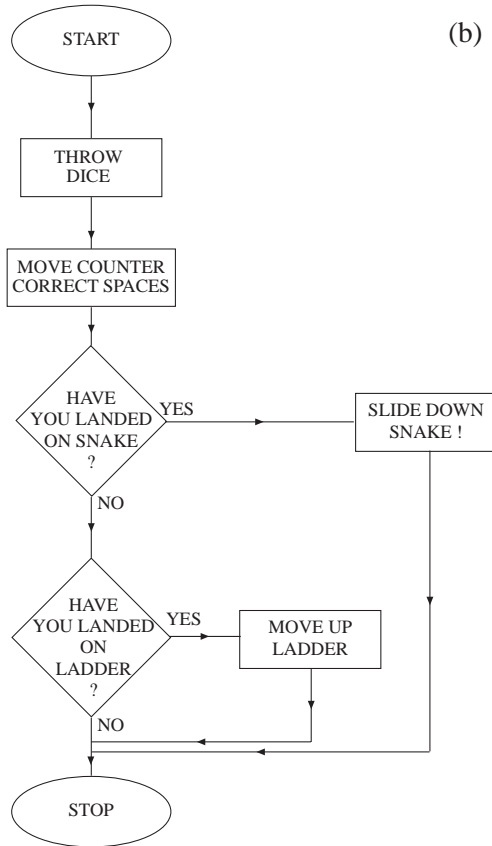

(b) Just before 'STOP' insert:

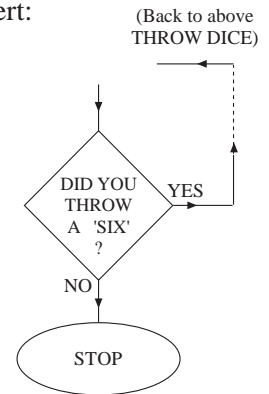

1.3 Using a Flow Chart for Classification

1. (a) A (b) E (c) C (d) B
 (e) A (f) C (g) D
2. (a) C (b) A (c) E (d) D
 (e) F (f) E

3.

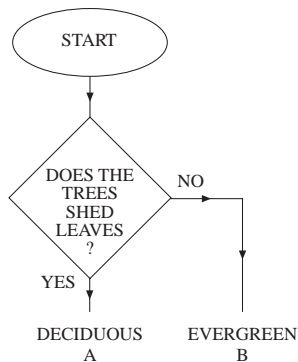

1.3

Answers

4.

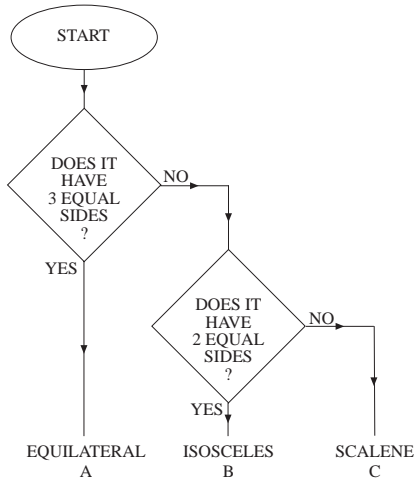

5.

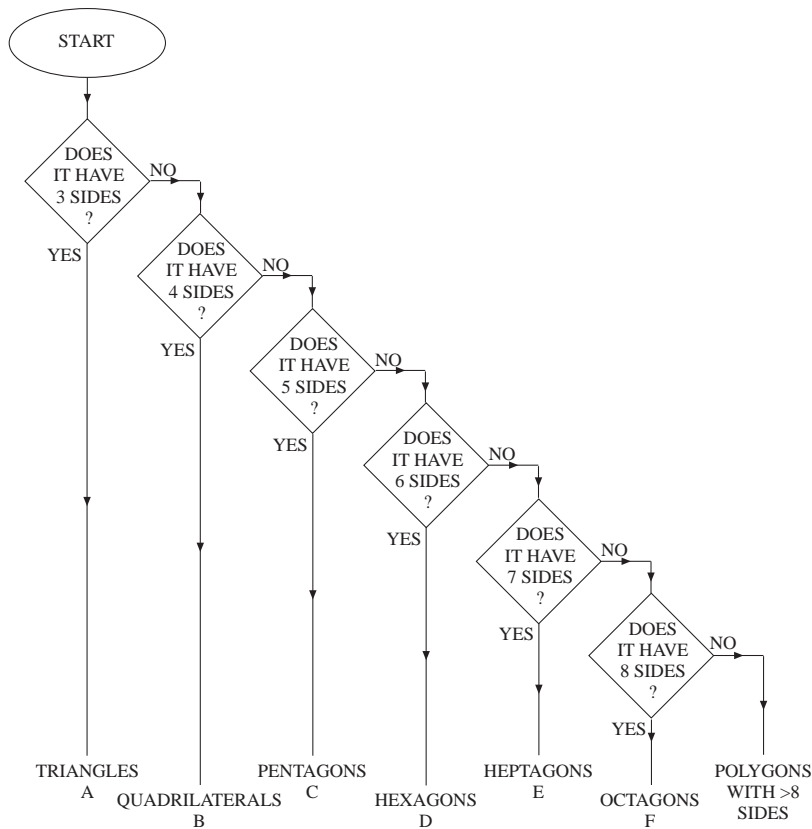

6. (a)
- | | | | | | |
|--------|---|-----------|---|----------|---|
| Monkey | D | Bird | C | Giraffe | B |
| Horse | B | Centipede | F | Elephant | B |
| Zebra | A | Pig | B | Kangaroo | B |
| Fish | E | Dolphin | E | Cat | B |

(b) For example:

- | | | | |
|---|----------|---|-------|
| A | Chipmunk | D | Ape |
| B | Lion | E | Shark |
| C | Man | | |

1.3

Answers

7. 1 comes out at E
 2 " " A
 3 " " C
 4 " " B
 5 " " E
 6 " " B
 7 " " E
 8 " " B
 9 " " D
 10 " " B

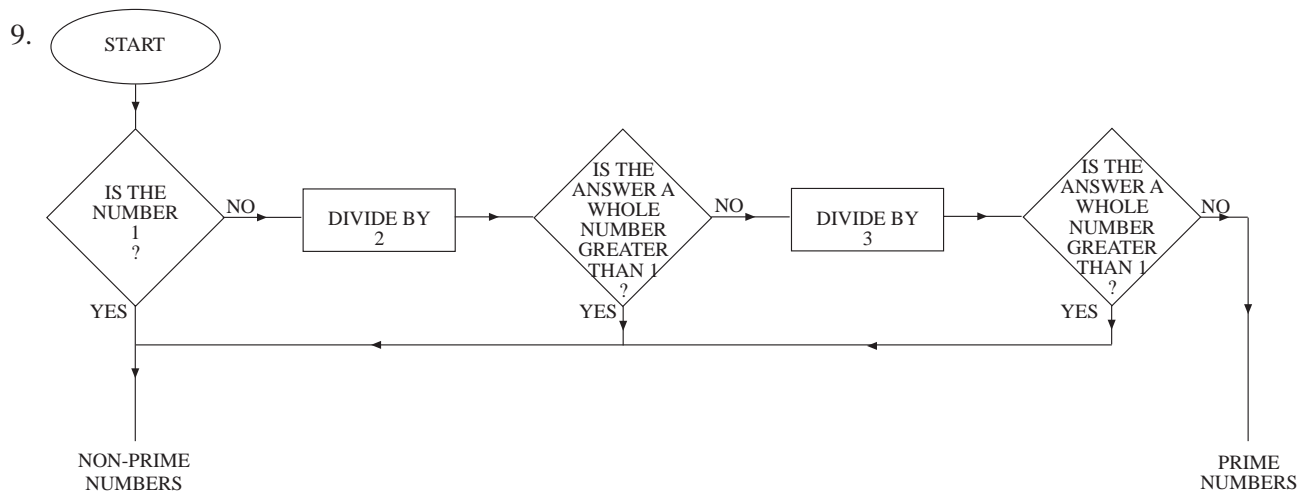
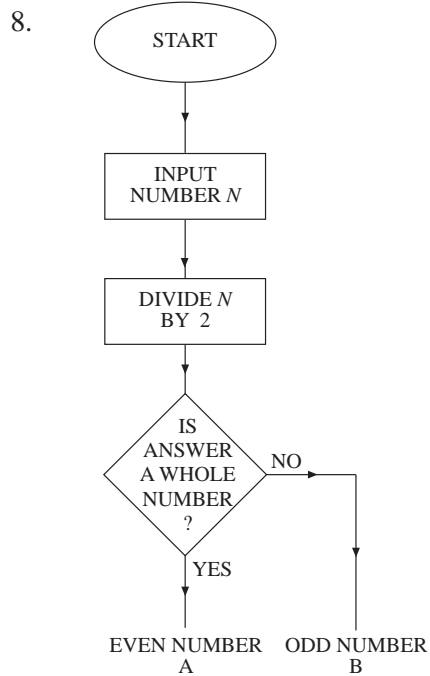

1.4

Answers

1.4 Networks

1. (a) Manchester → Buxton → Nottingham 25 + 46 = 71 miles
 (b) Sheffield → Nottingham → Birmingham 38 + 49 = 87 miles
2. S A B T = 4 hours
3. (a) Bodmin → Okehampton → Exeter 41 + 22 = 63 miles
 (b) Plymouth → Okehampton → Barnstaple → Minehead 31 + 30 + 38 = 99 miles
4. (a) Douglas → St John's → Kirkmichael → Sulby 6 + 6 + 6 = 18 miles
 (b) *Either* Ramsey → Laxey → Douglas → Ballasalla → Port Erin
 or Ramsey → Sulby → Kirkmichael → St John's → Ballasalla → Port Erin
 Distance = 29 miles
 (c) Peel → St John's → Douglas → Laxey 3 + 6 + 8 = 17 miles
5. Carlisle → York → Lincoln 117 + 80 = 197 miles

1.5 Critical Path Analysis

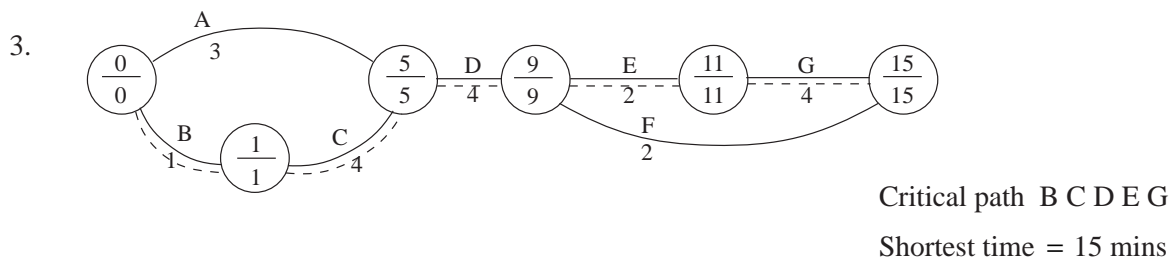
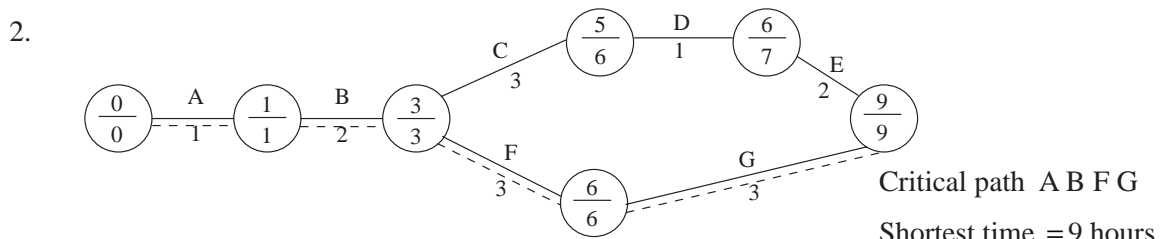
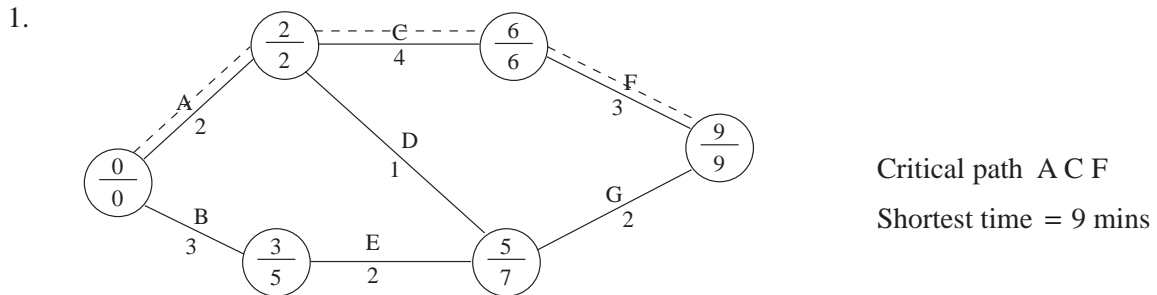

1.5

Answers

4. (a)

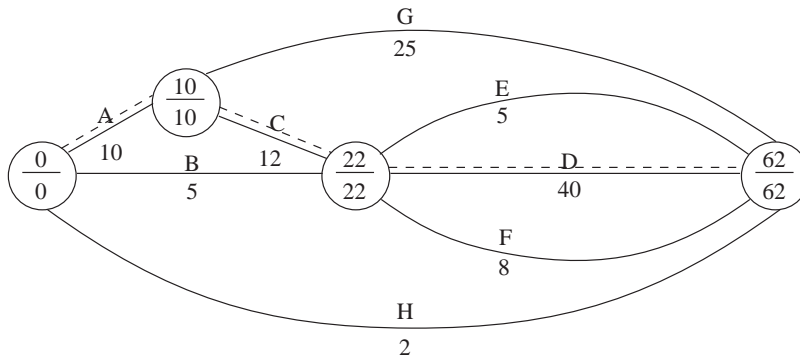

(b) Critical path A C D Shortest time = 62 mins

(c) Float times:

B 7 mins; E 35 mins; F 32 mins; G 20 mins; H 60 mins

5.

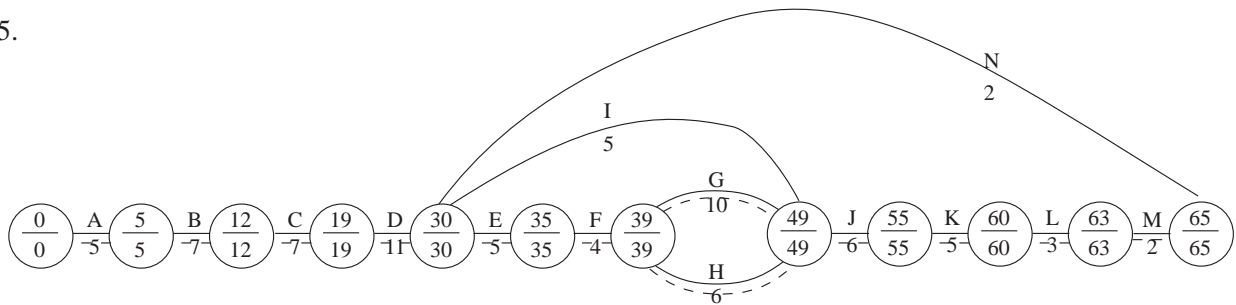

Critical path A B C D E F G J K L M

Shortest time = 65 hours

Practice Book *UNIT 2 Factors*

Answers

2.1 Factors and Prime Numbers

1. (a)

| <i>Number</i> | <i>Factors</i> |
|---------------|--------------------|
| 11 | 1, 11 |
| 12 | 1, 2, 3, 4, 6, 12 |
| 13 | 1, 13 |
| 14 | 1, 2, 7, 14 |
| 15 | 1, 3, 5, 15 |
| 16 | 1, 2, 4, 8, 16 |
| 17 | 1, 17 |
| 18 | 1, 2, 3, 6, 9, 18 |
| 19 | 1, 19 |
| 20 | 1, 2, 4, 5, 10, 20 |

(b) Prime numbers are:
11, 13, 17, 19

2. 99 not prime because factors are 1, 3, 9, 11, 33, 99

3. 37

4. Prime factors are 2, 3

5. (a) Prime factors are 2, 5 (b) Prime factors are 2, 5, 7 (c) 2 and 5

6.

| <i>Number</i> | <i>Factors</i> | <i>Prime Factors</i> | <i>Common Prime Factors</i> |
|---------------|----------------------------------|----------------------|-----------------------------|
| 48 | 1, 2, 3, 4, 6, 8, 12, 16, 24, 48 | 2, 3 | 2, 3 |
| 54 | 1, 2, 3, 6, 9, 18, 27, 54 | 2, 3 | 2, 3 |

7. $2 \times 5 \times 7 = 70$

8. $2 \times 3 \times 5 \times 7 \times 11 = 2310$

9. 101, 103

10. 211

2.2 Prime Factors

1. For example,
(a)

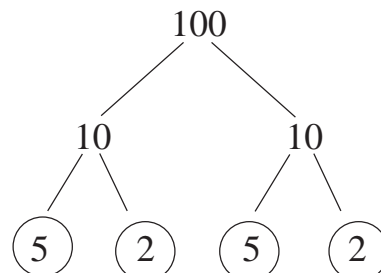
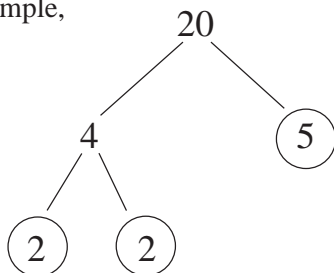

2.2

Answers

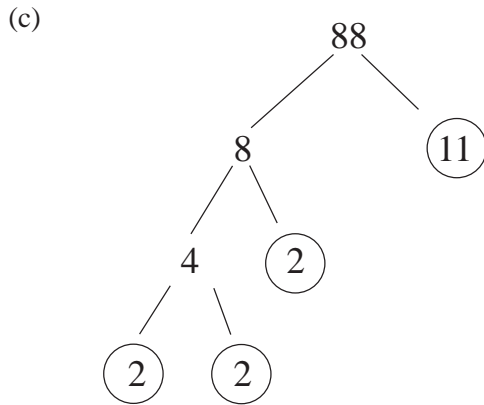

2. For example,

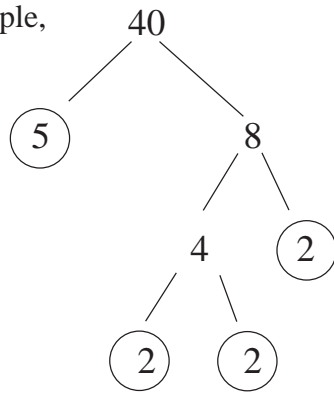

and

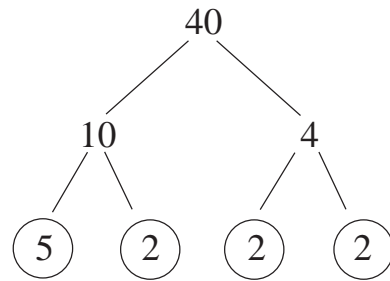

3. For example,

(a)

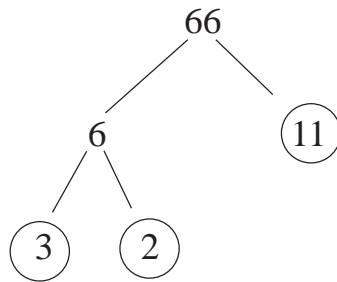

and

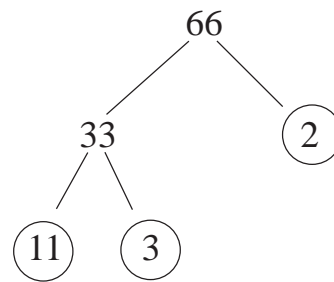

(b) Yes: for example,

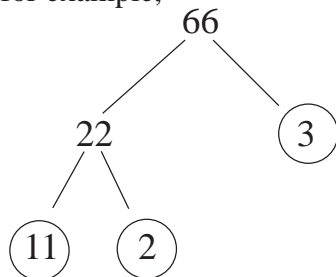

2.2

Answers

4.

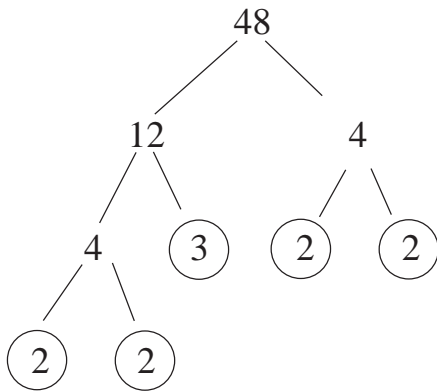

5.

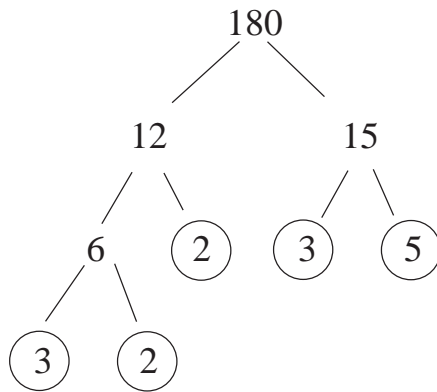

6. For example,

(a)

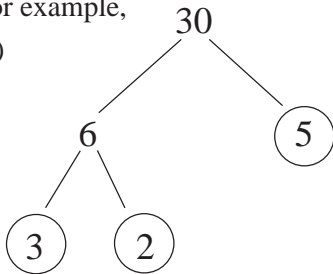

(b)

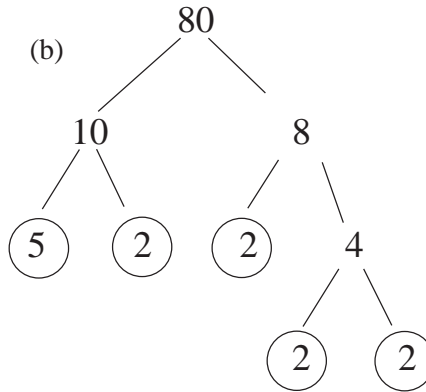

(c)

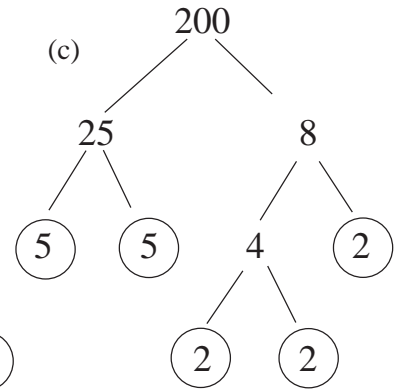

Distinct prime factors:

2, 3 and 5

2 and 5

2 and 5

7.

(a) 2×31

(b) 2^6

(c) 2×41

(d) $2^6 \times 5$

(e) $2 \times 3^2 \times 5$

(f) $2^3 \times 3 \times 5$

(g) 2×3^3

(h) 2×19

(i) $2^3 \times 5^3$

8.

$2^3 \times 3 \times 5^2 = 600$

9.

$2 \times 7 \times 11 = 154$

$2^2 \times 7 \times 11 = 308$

$3 \times 2 \times 7 \times 11 = 462$

10.

(a) $2 \times 3 \times 5 \times 7 = 210$

(b) $2^5 = 32$

11.

(a) 8×125

(b) 64×15625

2.3

Answers

2.3 Index Notation

1. (a) 6^5 (b) 3^4 (c) 7^6 (d) 9^5
2. (a) 8 (b) 27 (c) 10 000 (d) 125 (e) 128
 (f) 81 (g) 81 (h) 1000 (i) 10 000 000
3. (a) 10^2 (b) 9^2 (c) 3^4
 (d) 2^4 (e) 4^2 (f) 7^4
4. (a) 100 (b) 144 (c) 392
 (d) 72 (e) 243 (f) 1000
5. (a) 2^8 (b) 5^9 (c) 6^6 (d) 7^{10} (e) 8^7
6. (a) 3^6 (b) 3^8
7. $n = 4$
8. $n = 6$
9. $n = 12$
10. (a) 10^4 (b) 6^5 (c) 4^3
 (d) 21^5 (e) 4^4 (f) 2^9

2.4 Highest Common Factor and Lowest Common Multiple

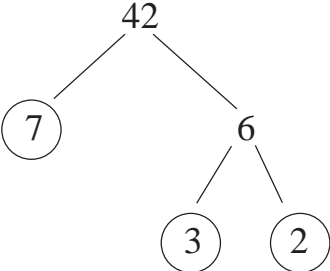
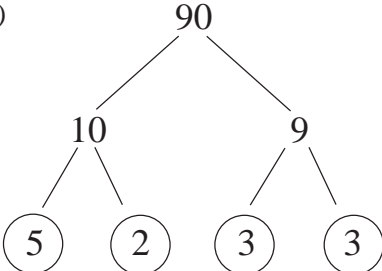
1. (a) 1, 3, 7, 21 (b) 1, 5, 7, 35 (c) HCF = 7
2. (a) 3 (b) 2 (c) 6 (d) 5
3. (a)  (b)  (c) $2 \times 3 = 6$

4. (a) 30 (b) 24 (c) 4
 (d) 1 (e) 50 (f) 64

2.4

Answers

5. (a) 8, 16, $\textcircled{24}$, 32, 40, 48, 56, 64, 72, 80
 (b) 6, 12, 18, $\textcircled{24}$, 36, 42, 48, 54, 60
 (c) 24

6. (a) 15 (b) 18 (c) 40
 (d) 36 (e) 60 (f) 66

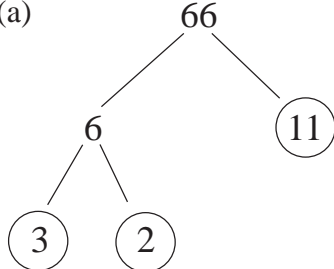
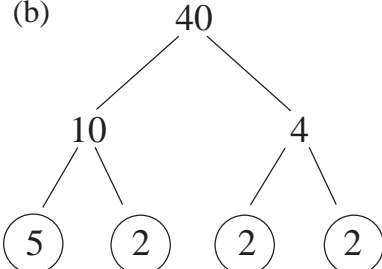
7. (a)  (b)  (c) 1320

8. (a) 420 (b) 48 (c) 100
 (d) 300 (e) 36 (f) 105

9. 120 secs

10. (a) 120 secs (b) 200 secs

2.5 Squares and Square Roots

1. (a) 4, 16, 81, 121, 144, 324, 400
 (b) 12, 4, 11, 2, 9, 20, 18

2. (a) 3 (b) 6 (c) 10
 (d) 13 (e) 15 (f) 0

3. (a) 2.45 (c) 3.16 (c) 3.46
 (d) 4.47 (e) 7.07 (f) 9.49

4. 9 cm

5. 11.8 cm = 118 mm

6. $7^2 = 49$; $8^2 = 64$ and $7^2 < 51 < 8^2$ giving $7 < \sqrt{51} < 8$

7. (a) $8 < \sqrt{70} < 9$ (b) $9 < \sqrt{90} < 10$ (c) $2 < \sqrt{5} < 3$
 (d) $1 < \sqrt{2} < 2$ (e) $10 < \sqrt{115} < 11$ (f) $6 < \sqrt{39} < 7$

2.5

Answers

8. (a) False ($3 < \sqrt{10} < 4$) (b) True

(c) True (d) False ($3.8 < \sqrt{15} < 3.9$)

9. 56 cm

10. 8 cm and 24 cm

Practice Book *UNIT 3 Pythagoras' Theorem*

Answers

3.1 Pythagoras' Theorem

1. (a) PQ (b) YZ (c) JK (d) ST
2. (a) (b) (c)
 - (i) 25 64 121
 - (ii) 144 225 3600
 - (iii) 169 289 3721
 - (iv) 169 289 3721
 - (v) $25 + 144 = 169$ $64 + 225 = 289$ $121 + 3600 = 3721$
3. (a) $10^2 + 24^2 = 100 + 576 = 676$
and $26^2 = 676$
i.e. equal
 - (b) $9^2 + 12^2 = 81 + 144 = 225$
and $15^2 = 225$
i.e. equal
 - (c) $13^2 + 84^2 = 169 + 7056 = 7225$
 $85^2 = 7225$
i.e. equal
4. (a) Yes (b) Yes (c) No (d) No

3.2 Calculating the Length of the Hypotenuse

1. (a) 10 cm (b) 39 mm (c) 41 mm (d) 34 mm
2. (a) 12.8 cm (b) 9.4 cm (c) 7.8 cm (d) 5.3 m
3. 11.2 cm (1 d.p.)
4. 8.5 cm (1 d.p.)
5. (a) PQ = 4.61 m (2 d.p.) (b) QS = 5 m (c) 20.11 m (2 d.p.)
6. (a) $x = 8.25$ cm (2 d.p.) (b) Perimeter = 20.5 m (1 d.p.)
7. 6.44 m (2 d.p.)
8. Extra length = $20.5 - 14.84$ m = 5.66 m
9. Rectangle A

3.2

Answers

10. (a) $c^2 = 10^2 + 1^2 = 101$
 $c = \sqrt{101} = 10.0499$ (4 d.p.) = 10.0 cm (1 d.p.)
(b) No; hypotenuse length accurate to only 1 d.p.

3.3 Calculating the Lengths of Other Sides

1. (a) 16 cm (b) 40 cm (c) 60 cm (d) 24 cm
2. (a) 16.7 cm (b) 6.6 cm (c) 3.3 cm (d) 6.2 cm
3. 3.5 cm
4. 4.3 cm (1 d.p.)
5. 7.4 cm (1 d.p.)
6. (a) 12 cm (b) 60 cm^2
7. $x^2 = 50$
 $x = \sqrt{50}$
 $x = 7.071067812$
 $x = 7.1 \text{ cm}$ (1 d.p.)
8. 5.66 cm (2 d.p.)
9. (a) 3 m (b) 2.6 m (1 d.p.)
10. (a) 1.3 m (b) 3.1 m
11. 0.92 m (2 d.p.)

3.4 Problems in Context

1. 500 m
2. 2.65 m (nearest cm)
3. 25 m
4. 6.40 m (nearest cm)
5. (a) 18.33 cm (2 d.p.) (b) 73.32 cm^2 (2 d.p.)
6. 27.4 cm (1 d.p.)
7. 22.77 cm (2 d.p.) = 228 mm (nearest mm)
8. 9.17 m (nearest cm)
9. 0.9 m
10. 7.13 m (nearest cm)

Answers

3.5 Constructions and Angles

1. (b) $90^\circ, 37^\circ, 53^\circ$ (c) Yes (d) $6^2 + 8^2 = 100 = 10^2$; right-angled
2. (b) $94^\circ, 46^\circ, 40^\circ$ (c) No (d) $7^2 + 8^2 = 113$
 $\neq 121 = 11^2$; not right-angled
3. (i) $10^2 + 11^2 \neq 14^2$ $c^2 < a^2 + b^2$ All acute angles
(ii) $10^2 + 12^2 \neq 16^2$ $c^2 > a^2 + b^2$ Contains an obtuse angle
(iii) $9^2 + 12^2 = 15^2$ $c^2 = a^2 + b^2$ Right-angled
4. (b) $6^2 + 7^2 \neq 12^2$ No right angle
5. Length of diagonal = 8.5 cm (1 d.p.) Not drawn that accurately.
6. $8^2 + 8^2 \neq 9^2$ and $c^2 < a^2 + b^2$ and so θ is an acute angle
8. (b) $x > 35$
9. (a) If sides are 18, 18, 28 then $18^2 + 18^2 \neq 28^2$
If sides are 28, 28, 18 then $28^2 + 28^2 \neq 18^2$
(b) For 3 acute angles, $c^2 < a^2 + b^2$. If $c = 18$ then $18^2 < 28^2 + 28^2$.
10. 40 cm or 21.2 cm (1 d.p.)

Practice Book *UNIT 4 Rounding and Estimating* **Answers**

4.1 Revision of the Four Rules: Whole Numbers

- | | | | | | | |
|-----|---------|---------|----------|----------|----------|----------|
| 1. | (a) 29 | (b) 46 | (c) 79 | (d) 174 | (e) 349 | (f) 557 |
| 2. | (a) 138 | (b) 123 | (c) 348 | (d) 239 | (e) 782 | (f) 1112 |
| 3. | (a) 12 | (b) 44 | (c) 51 | (d) 15 | (e) 219 | (f) 551 |
| 4. | (a) 157 | (b) 511 | (c) 42 | (d) 188 | (e) 786 | (f) 3452 |
| 5. | (a) 36 | (b) 55 | (c) 46 | (d) 93 | (e) 88 | (f) 606 |
| 6. | (a) 95 | (b) 344 | (c) 234 | (d) 189 | (e) 387 | (f) 520 |
| 7. | (a) 902 | (b) 444 | (c) 1638 | (d) 1242 | (e) 2074 | (f) 5655 |
| 8. | (a) 34 | (b) 16 | (c) 41 | (d) 169 | (e) 52 | (f) 201 |
| 9. | (a) 12 | (b) 60 | (c) 20 | (d) 42 | (e) 30 | (f) 15 |
| 10. | (a) 261 | (b) 441 | (c) 91 | (d) 1548 | (e) 183 | (f) 816 |

4.2 Revision of the Four Rules: Decimals

- | | | | | | | |
|----|----------|----------|-----------|-----------|-----------|-----------|
| 1. | (a) 7.7 | (b) 48.7 | (c) 5.3 | (d) 17.91 | (e) 19.02 | (f) 3.752 |
| 2. | (a) 4.3 | (b) 14.2 | (c) 2.4 | (d) 3.7 | (e) 6.28 | (f) 2.03 |
| 3. | (a) 8.6 | (b) 14 | (c) 44.4 | (d) 43.4 | (e) 164.7 | (f) 28.1 |
| 4. | (a) 3.4 | (b) 21.3 | (c) 13.1 | (d) 15.1 | (e) 14.2 | (f) 25.3 |
| 5. | (a) 21.1 | (b) 57.6 | (c) 4.79 | (d) 70.4 | (e) 796.2 | (f) 5.23 |
| 6. | (a) 1.68 | (b) 3.45 | (c) 1.008 | (d) 31.96 | (e) 2.592 | (f) 7.462 |
| 7. | (a) 62 | (b) 149 | (c) 18 | (d) 2.1 | (e) 500 | (f) 2.1 |
| 8. | (a) 54 | (b) 7.83 | (c) 4.34 | (d) 0.544 | (e) 1.05 | (f) 7.437 |

4.3 Order of Operations

- | | | | | | | | | | | |
|----|-----------------------------|-----------------------------|---------------------------|-------------------------|-----------------------------|------------------------------|-----------|-----------|--------|-------|
| 1. | (a) 20 | (b) 2 | (c) 7 | (d) 9 | (e) 25 | (f) 35 | (g) 61 | (h) 15 | (i) 25 | (j) 9 |
| 2. | (a) T | (b) F, 35 | (c) F, 21 | (d) F, 24 | (e) F, 7 | (f) T | (g) F, 46 | (h) F, 56 | | |
| 3. | (a) $3 \times (6 + 1) = 21$ | (b) $(5 + 6) \times 2 = 22$ | (c) $45 \div (6 + 3) = 5$ | (d) $49 - (3 + 2) = 44$ | (e) $7 \times (3 + 2) = 35$ | (f) $(13 - 4) \times 2 = 18$ | | | | |
| 4. | (a) 5 | (b) 6 | (c) 6 | (d) 3 | (e) 2 | (f) 12 | | | | |

4.3

Answers

5. (a) Jane has forgotten to use brackets. Correct answer is 34.
 (b) $(4 \times 7 + 2) \times 3 = 90$
6. (a) No (b) $30 \div 6 - (3 + 1) = 1$ (c) $30 \div (6 - 3) + 1 = 11$
7. (a) T (b) T (c) F (d) F
8. (a) $13 - (4 - 1) = 10$ (b) $30 - (9 + 2) = 19$ (c) $60 \div (6 \div 3) = 30$
9. (a) 40.9 (b) 0.62 (c) 4.92 (d) 2.06
10. (a) 4 (b) 3 (c) 0.8 (d) 0.9

4.4 Problems in Context

1. (a) £3.75 (b) £17.50
2. 5; £3 change
3. £209.70; $30 \times £7.00 - 30p$
4. 42 (and £6 left)
5. (a) £19 (b) £23.48
6. 7
7. £5.25
8. £13.25
9. 19; 5 left over
10. £6.06

4.5 Rounding

1. (a) 4 (b) 2 (c) 17 (d) 4 (e) 33 (f) 19
2. (a) 190 (b) 310 (c) 10 (d) 40 (e) 40 (f) 20
3. (a) 36 000 (b) 36 500 (c) 36 480
4. (a) 4.26 (b) 0.05 (c) 10.84 (d) 82.06 (e) 3.45 (f) 9.40
5. (a) 1.5 (b) 6.3 (c) 3.2 (d) 11 (e) 140 (f) 1400
6. (a) 8.646 (b) 8.6457 (c) 8.6
7. (a) 147.5 (b) 148 (c) 150 (d) 100
8. (a) 105 (b) 104.74 (c) 100 (d) 104.7 (e) 100

4.5

Answers

9. (a) 18.5 (b) 0.00327 (c) 147 000
 (d) 63.0 (e) 0.0362 (f) 0.000369

| 10. | <i>No.</i> | <i>Statement</i> |
|-----|------------|------------------|
| | 0.047 | 2 s.f. |
| | 0.003 | 3 d.p. |
| | 16.22 | 2 d.p. |
| | 184 200 | 4 s.f. |
| | 7.06 | 3 s.f. |

4.6 Estimating

| 1. | <i>Estimate *</i> | <i>Calculator</i> |
|-----|------------------------|-------------------|
| (a) | $5 \times 8 = 40$ | 39.198 |
| (b) | $10 \times 21 = 210$ | 205.728 |
| (c) | $11 \times 8 = 88$ | 91.9092 |
| (d) | $18 \times 110 = 1980$ | 1976.4 |
| (e) | $100 \times 75 = 7500$ | 7220 |
| (f) | $15 \times 25 = 375$ | 383.46 |

2. $8 \times 50 = 400$ *

3. (a) $3.5 \times 5 = 17.5 \text{ m}^2$ * (b) 17.0392 m^2 (c) Comparison acceptable

4. $20 \times 40\text{p} = \text{£}8.00$ *

5. A, B, D and E all incorrect

6. (a) 4 or 5 * (b) 7 or 8 * (c) 40 * (d) 700 * (e) 2 * (f) 25 *

7. $\text{£}150$ *

8. 48 litres *

9. (a) 30 litres * (b) 29.16 litres (c) Estimate acceptable

10. $\text{£}20 \times 26500 = \text{£}530000$ *

* other acceptable answers

Answers

4.7 Calculator Logic

1. (a) 45.9 (b) 6.27 (3 s.f.) (c) 7.67 (3 s.f.) (d) 5.57 (3 s.f.)
(e) 1.08 (3 s.f.) (f) 1.21 (3 s.f.)
2. (a) 0.509 (3 s.f.) (b) 0.522 (3 s.f.) (c) 3.05 (3 s.f.) (d) 0.155 (3 s.f.)
3. (a) 8.375 (b) 2.82 (c) 8.660 (3 d.p.) (d) 3.975 (3 d.p.)
4. (a) 12 (b) 12.01
5. (a) 0.6 (b) Failed to use brackets when dividing; he did $\frac{6}{8} + 2$
6. (a) No (b) No (c) Yes (d) No, if you pressed $\boxed{=}$ after '6';
Yes, if you didn't.
7. (a) 7.88 (2 d.p.) (b) 7.9 (2 s.f.)
8. (a) $\frac{6}{8-7+2}$ (b) $4 + 7 \times (9 + 4)$ (c) $\frac{4}{8-5} + 6$ (d) $1 + \frac{7 \times (8-3)}{(2+9)}$
9. (a) 2.45 (b) 1.05 (3 s.f.) (c) 0.861 (3 s.f.)

Practice Book *UNIT 5 Data Analysis*

Answers

5.1 Frequency Tables: Discrete Ungrouped Data

1. (a)

| <i>No. of Conkers</i> | <i>No. of Days</i> | <i>Angle (°)</i> |
|-----------------------|--------------------|------------------|
| 1 | 1 | 36 |
| 2 | 3 | 108 |
| 3 | 2 | 72 |
| 4 | 2 | 72 |
| 5 | 1 | 36 |
| 6 | 0 | 0 |
| 7 | 0 | 0 |
| 8 | 0 | 0 |
| 9 | 0 | 0 |
| 10 | 1 | 36 |

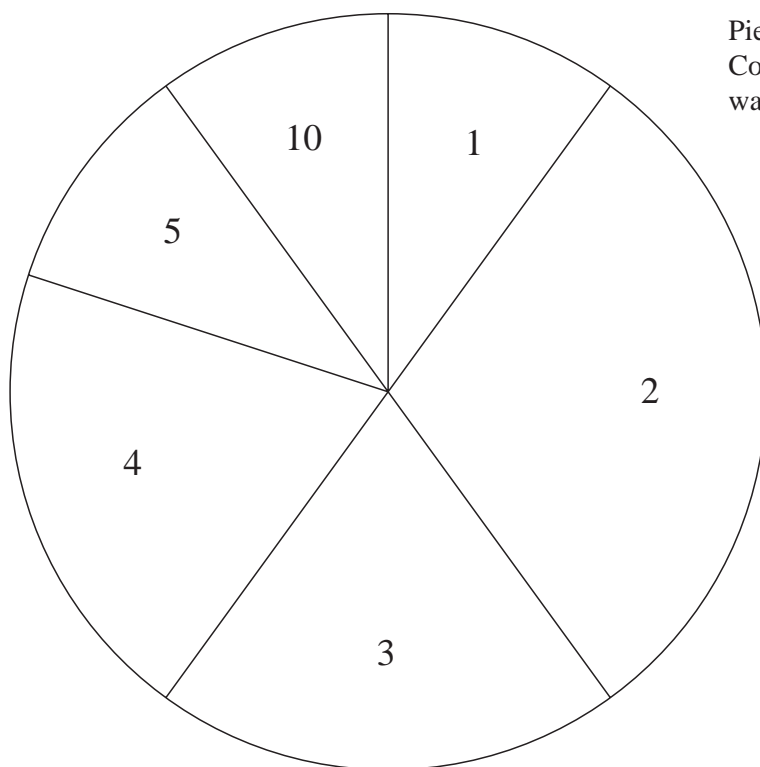

Pie Chart Showing Number of Conkers Collected in 2 weeks on way to school

- (b) The weather could have been very windy on the day Emma collected 10 conkers.

5.1

Answers

| 2. | (a) | <i>No. of Videos Borrowed</i> | <i>No. of Occasions</i> | <i>Angle (°)</i> |
|----|-----|-------------------------------|-------------------------|------------------|
| | | 2 | 3 | 36 |
| | | 3 | 4 | 48 |
| | | 4 | 5 | 60 |
| | | 5 | 3 | 36 |
| | | 6 | 4 | 48 |
| | | 7 | 3 | 36 |
| | | 8 | 3 | 36 |
| | | 9 | 2 | 24 |
| | | 10 | 2 | 24 |
| | | 11 | 0 | 0 |
| | | 12 | 1 | 12 |
| | | | <u>30</u> | <u>360</u> |

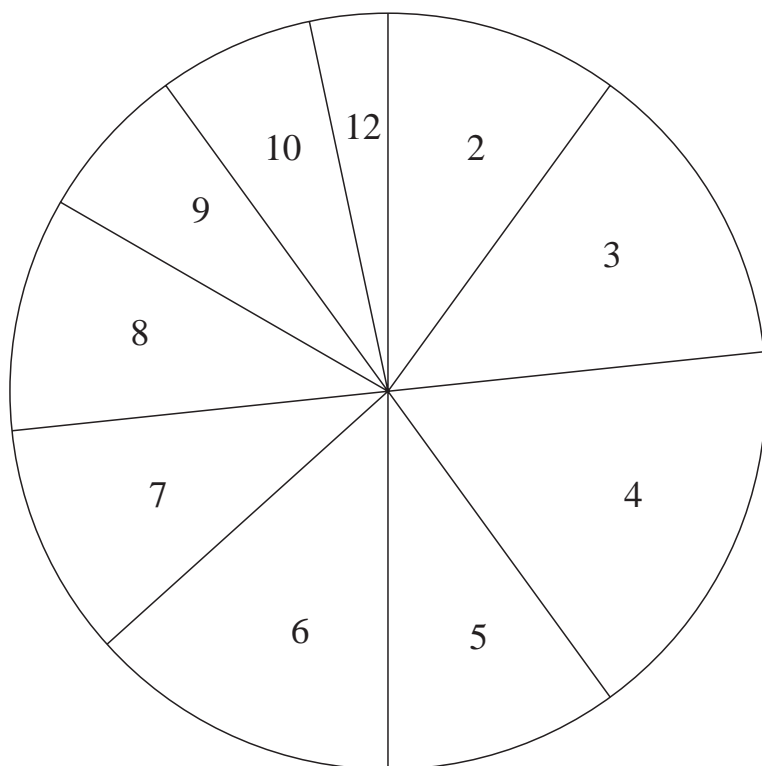

Pie Chart Showing Number of Videos borrowed each hour from Mr Rafiq's Video Library

- (b) 12
 (c) 2
 (d) 4

5.1

Answers

3. (a)

| <i>No. of Goals</i> | <i>No. of Matches</i> | <i>Angle (°)</i> |
|---------------------|-----------------------|------------------|
| 0 | 2 | 72 |
| 1 | 2 | 72 |
| 2 | 1 | 36 |
| 3 | 1 | 36 |
| 4 | 3 | 108 |
| 5 | 1 | 36 |
| | <u>10</u> | <u>360</u> |

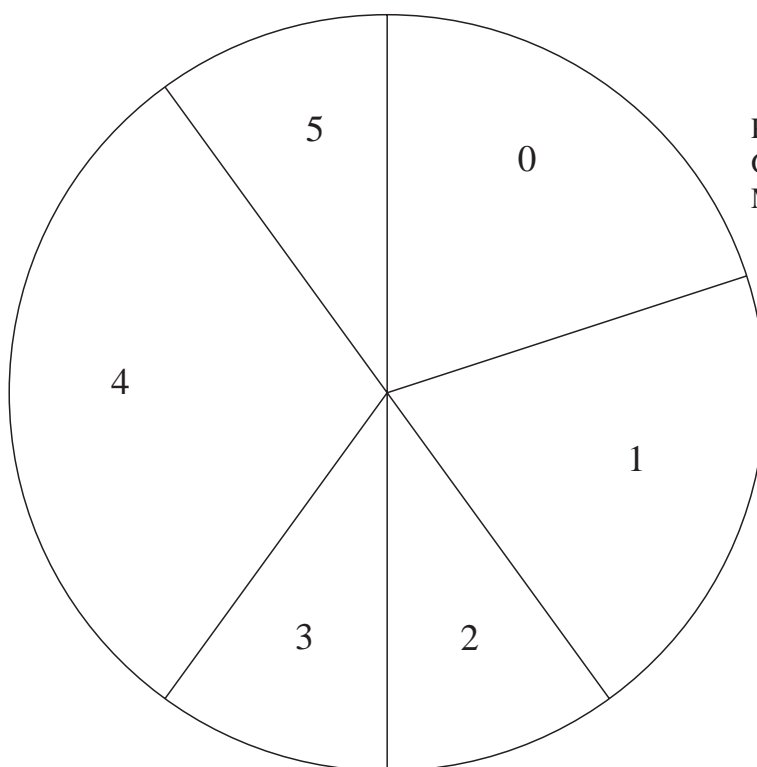

Pie Chart Showing Number of Goals Scored in Premier League Matches one Saturday

(b) 4

4. (a) 15°

(b)

| <i>Score</i> | <i>Pupils</i> |
|--------------|---------------|
| 3 | 3 |
| 4 | 6 |
| 5 | 4 |
| 6 | 1 |
| 7 | 6 |
| 8 | 2 |
| 9 | 1 |
| 10 | 1 |

5.1

Answers

5. (a)

| <u>Level</u> | <u>No. of Pupils</u> |
|--------------|----------------------|
| 3 | 1 |
| 4 | 8 |
| 5 | 9 |
| 6 | 10 |

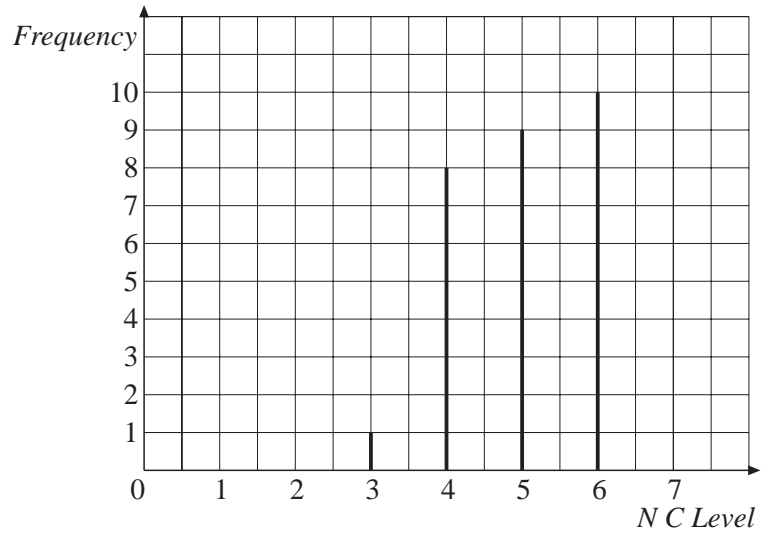

(b) Level 6

6. (a)

| <u>Level</u> | <u>No. of Pupils</u> |
|--------------|----------------------|
| 3 | 3 |
| 4 | 10 |
| 5 | 9 |
| 6 | 6 |

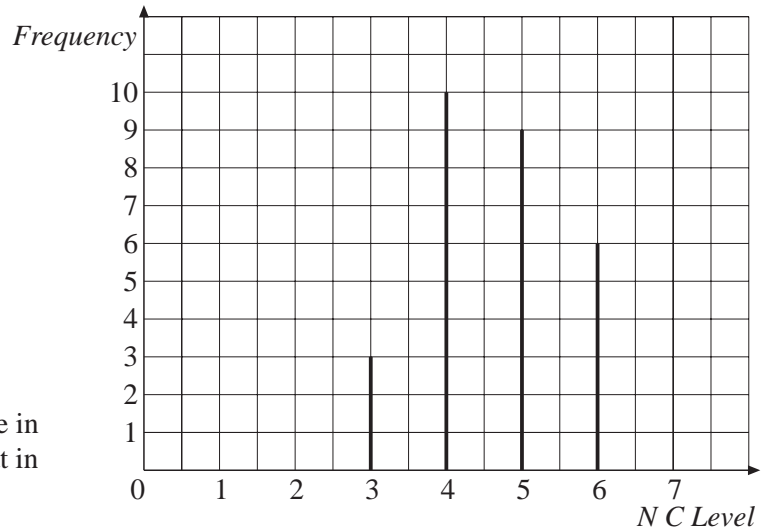

(b) Generally, the performance in English was lower than that in Maths.

7. (a)

| <u>Digits</u> | <u>No. of Times</u> |
|---------------|---------------------|
| 0 | 4 |
| 1 | 6 |
| 2 | 4 |
| 3 | 4 |
| 4 | 3 |
| 5 | 4 |
| 6 | 3 |
| 7 | 4 |
| 8 | 2 |
| 9 | 6 |

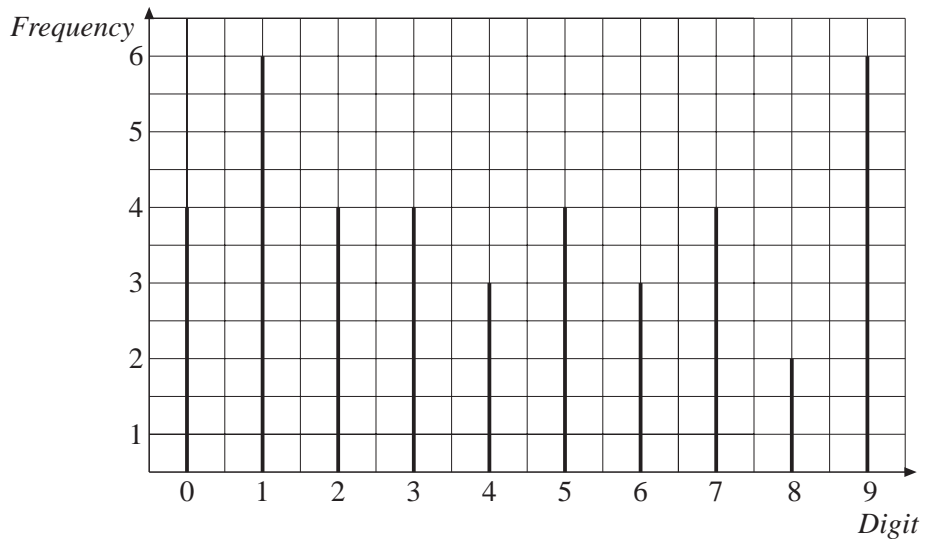

(b) Reasonably even spread of digits over a relatively small sample.

5.1

Answers

| 8. (a) | <i>No. of Trains Late</i> | <i>January</i> | <i>February</i> |
|--------|---------------------------|----------------|-----------------|
| | 0 | 3 | 0 |
| | 1 | 7 | 1 |
| | 2 | 6 | 1 |
| | 3 | 4 | 5 |
| | 4 | 5 | 9 |
| | 5 | 2 | 5 |
| | 6 | 1 | 3 |
| | 7 | 2 | 1 |
| | 8 | 0 | 2 |
| | 9 | 1 | 1 |

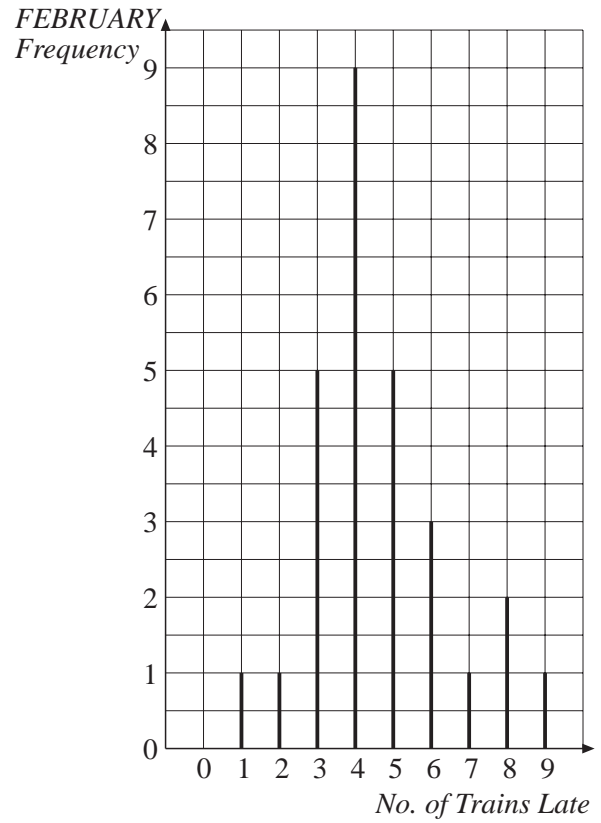
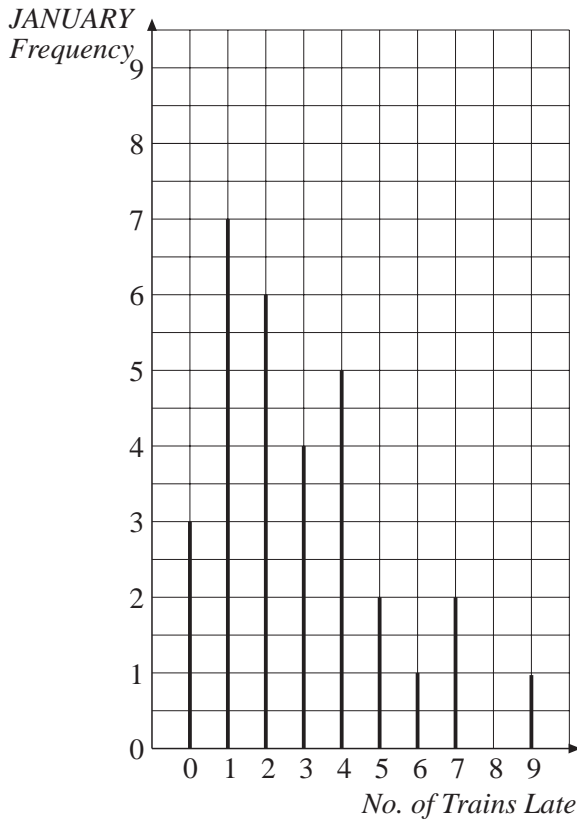

- (b) January
- (c) Different length of months
- (d) Quite possibly

5.1

Answers

9. (a)

| <i>No. of Tomatoes</i> | <i>1997</i> | <i>1998</i> |
|------------------------|-------------|-------------|
| 6 | 2 | 0 |
| 7 | 3 | 0 |
| 8 | 5 | 2 |
| 9 | 4 | 1 |
| 10 | 5 | 1 |
| 11 | 2 | 4 |
| 12 | 5 | 3 |
| 13 | 0 | 0 |
| 14 | 1 | 1 |
| 15 | 1 | 5 |
| 16 | 1 | 3 |
| 17 | 0 | 4 |
| 18 | 0 | 2 |
| 19 | 1 | 2 |
| 20 | 1 | 2 |

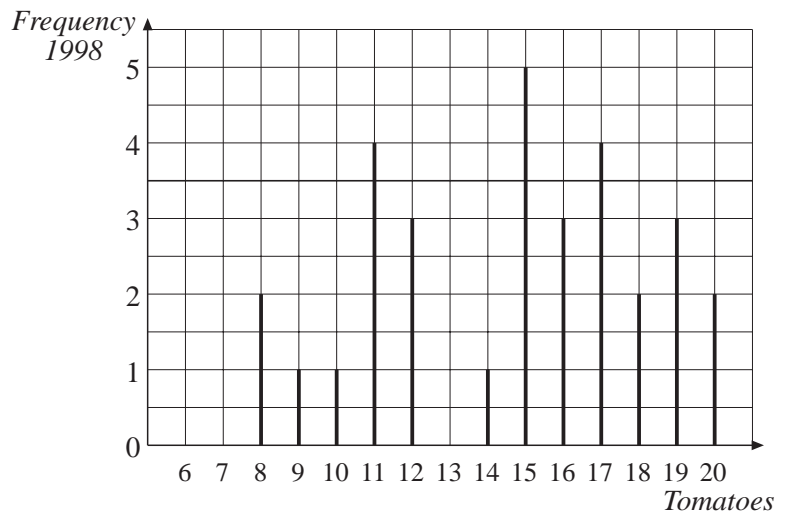
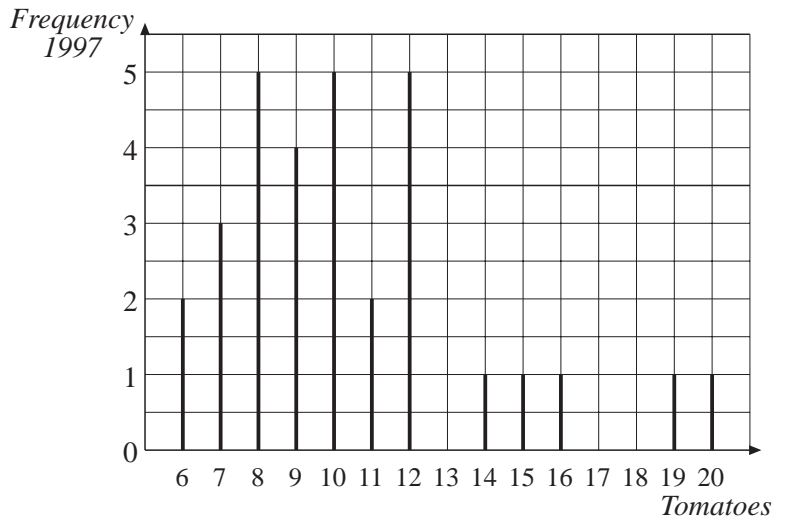

(b) 1998 was a more productive year than 1997.

5.2 Mean, Median, Mode and Range

1.

| | <i>Mean</i> | <i>Median</i> | <i>Mode</i> | <i>Range</i> |
|-----|-------------|---------------|-------------|--------------|
| (a) | 5 | 4 | 3 | 6 |
| (b) | 11 | 11 | 12 | 5 |
| (c) | 7.5 | 7.5 | none | 5 |
| (d) | 5.5 | 5 | 5 | 7 |

5.2

Answers

2.

| <i>Score</i> | <i>Frequency</i> | <i>Score × Frequency</i> |
|--------------|------------------|--------------------------|
| 0 | 2 | 0 |
| 1 | 6 | 6 |
| 2 | 8 | 16 |
| 3 | 3 | 9 |
| 4 | 0 | 0 |
| 5 | 1 | 5 |
| Totals | 20 | 36 |

(b) $\text{Mean} = \frac{36}{20}$
 $= 1.8$

3.

| <i>No. of Goals</i> | <i>Tally</i> | <i>Frequency</i> | <i>No. of Goals × Frequency</i> |
|---------------------|--------------|------------------|---------------------------------|
| 0 | | 5 | 0 |
| 1 | | 10 | 10 |
| 2 | | 7 | 14 |
| 3 | | 4 | 12 |
| 4 | | 2 | 8 |
| 5 | | 1 | 5 |
| 6 | | 1 | 6 |
| Totals | 30 | 30 | 55 |

- (b) Mean = 1.83 (2 d.p.)
- (c) Median = 1.5
- (d) Mode = 1 goal
- (e) Range = 6

4. Mean = 76.68p Median = 77p Mode = 77p

5. (a) Mean = 2.1 children (b) Median = 2 children
 (c) Because each family has at least 1 child – those in the class!

6. Mean = 72.3

7. (a) Mean = 5.24 Median = 5 Mode = 4
 (b) Modal value

8. (a) Mean = 2.44 vacuum cleaners Median = 2 vacuum cleaners Mode = 4 vacuum cleaners
 (b) Mode

9. (a)

| | <i>Class A</i> | <i>Class B</i> |
|--------|----------------|----------------|
| Mean | 6.88 | 6.88 |
| Median | 7 | 7 |
| Mode | 6 and 8 | 10 |

(b) None (c) Mode

5.2

Answers

| | | | | |
|-----|-------|-------------|---------------|-------------|
| 10. | | <i>Mean</i> | <i>Median</i> | <i>Mode</i> |
| | Paul | 72.65 | 72 | 72 |
| | David | 73.15 | 71 | 70 |

Paul is the better player because his mean is 72.65 compared with David's 73.15.

David is the better player because his median score is 71 compared with Paul's 72 and also he scores 70 (the mode) more often than Paul who gets 72 most frequently.

Practice Book *UNIT 6 Nets and Surface Area*

Answers

6.1 Common 2-D and 3-D Shapes

1. Rhombus or square or rectangle
2. Regular hexagon
- 3.

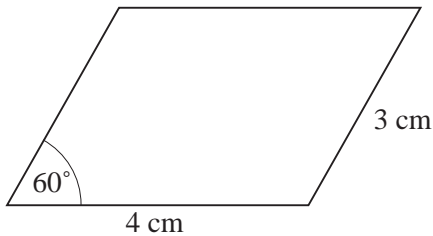

4. Yes: rhombus
5. Yes: rectangle
6. Square, rectangle, rhombus, parallelogram, kite
7. Trapezium, quadrilateral

6.2 2-D Representation of 3-D Shapes

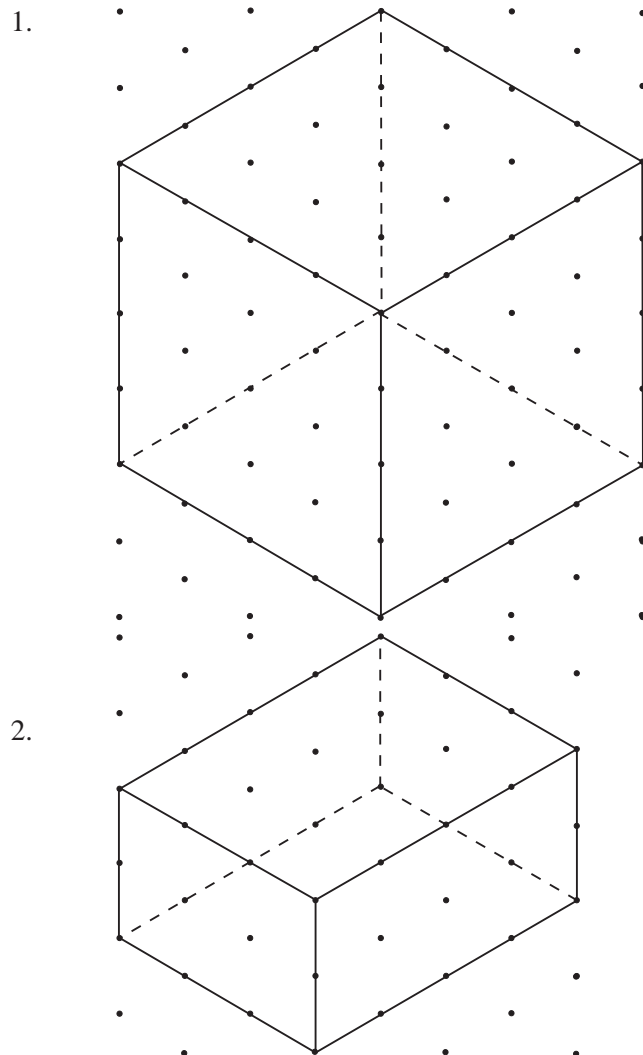

6.2

Answers

3.

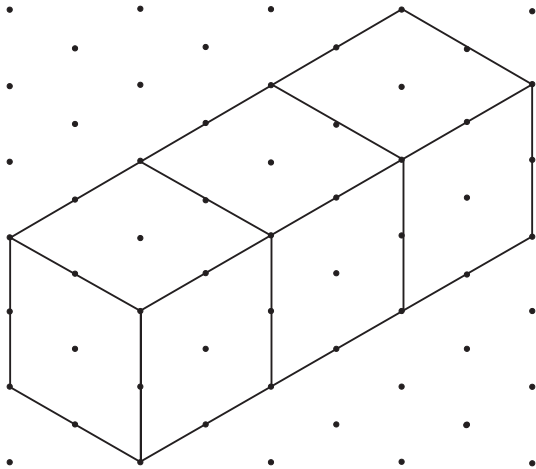

4.

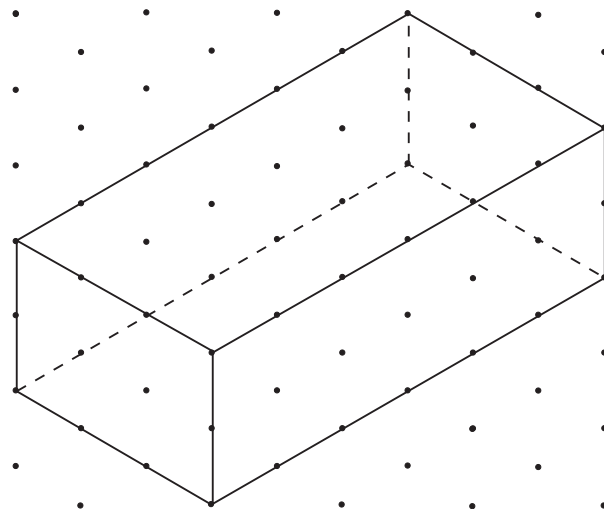
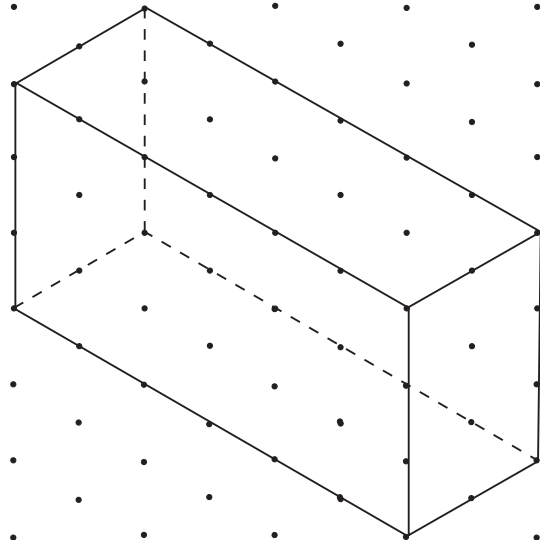
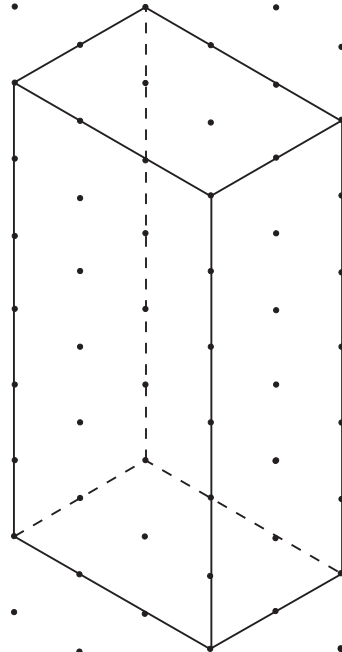

6.2

Answers

5.

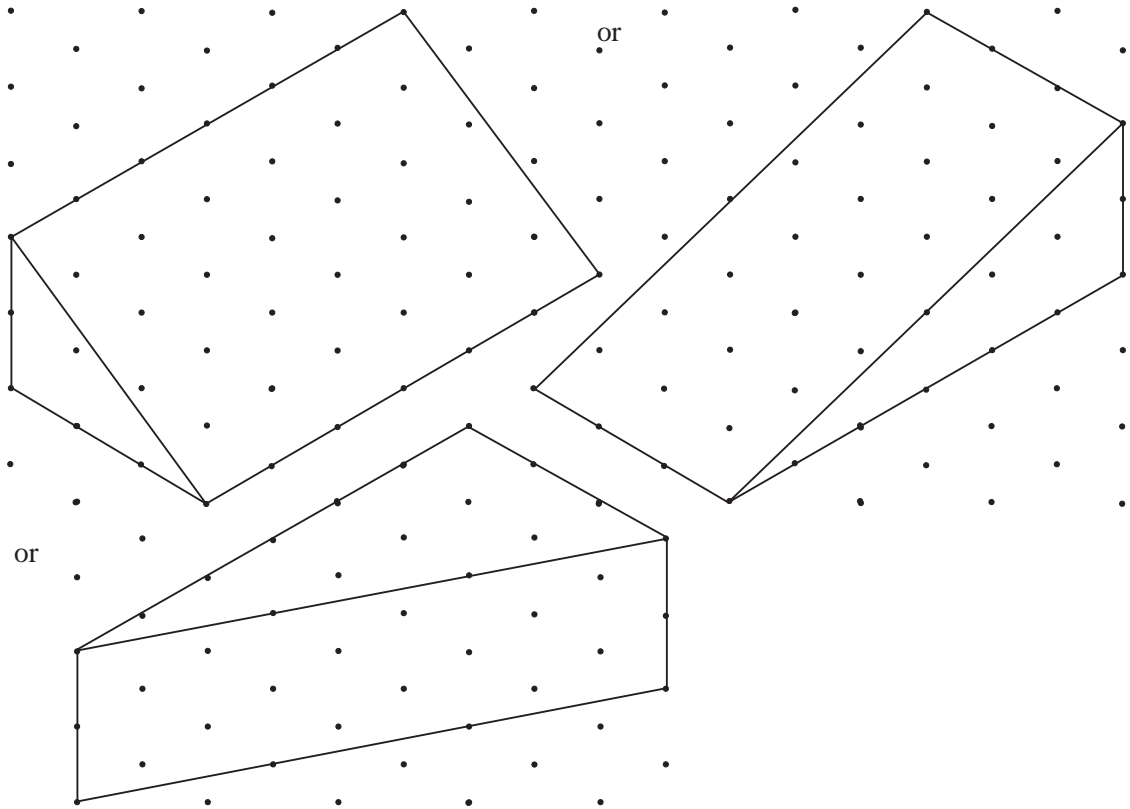

6.

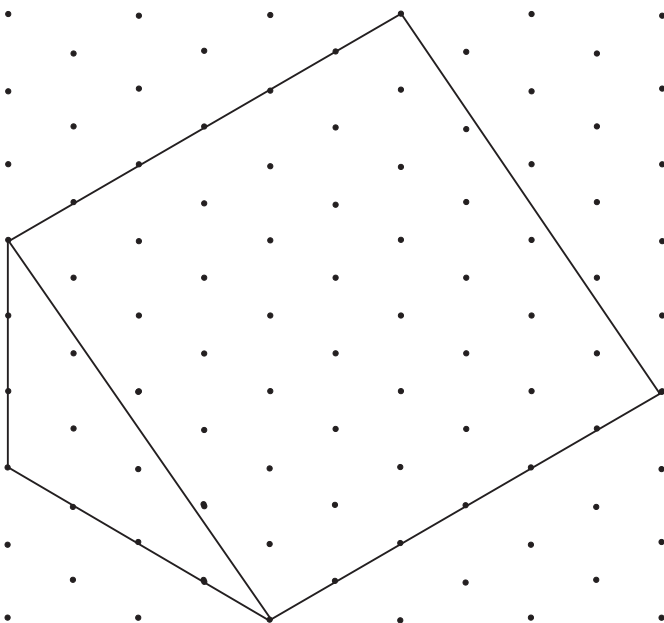

6.2

Answers

7.

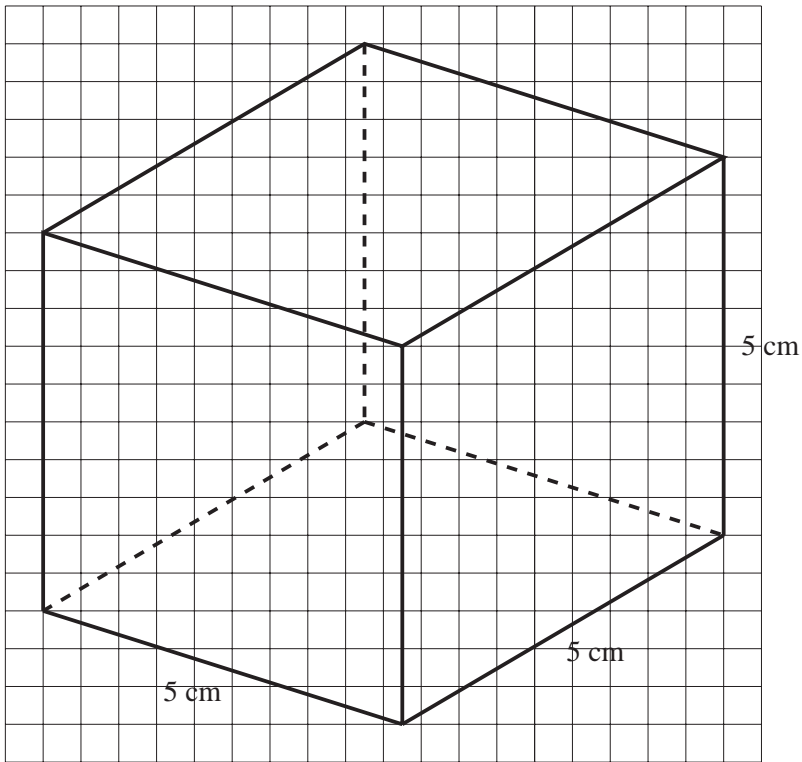

8.

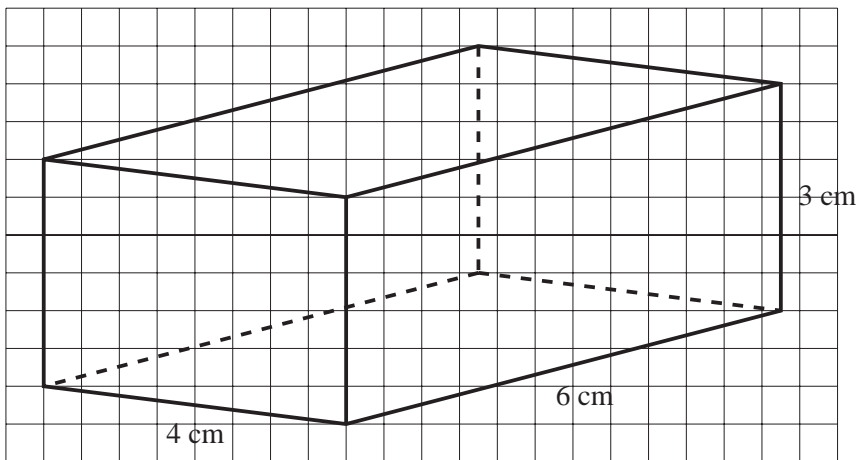

9.

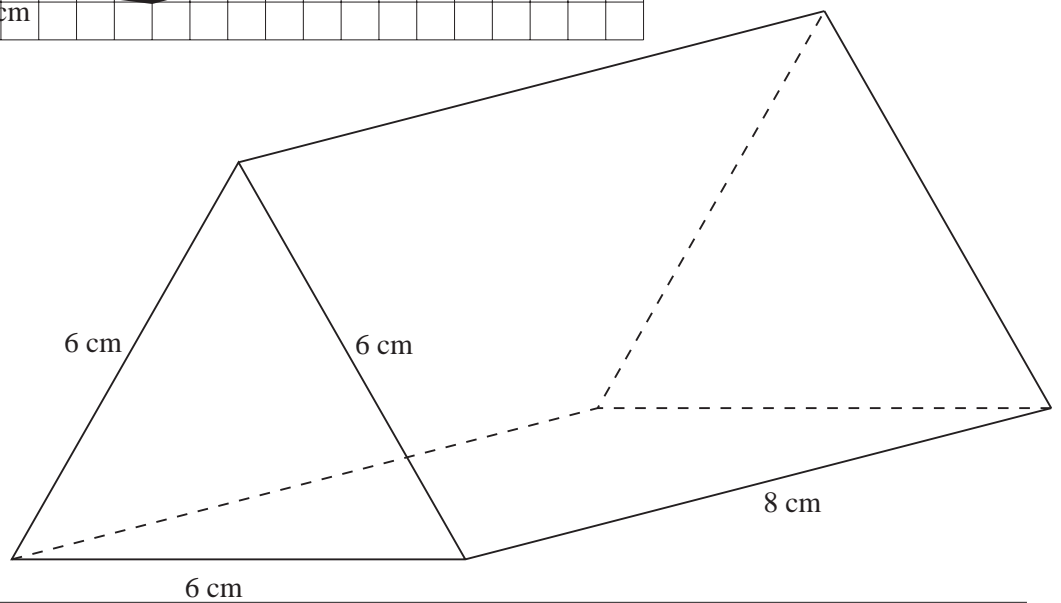

6.2

Answers

10.

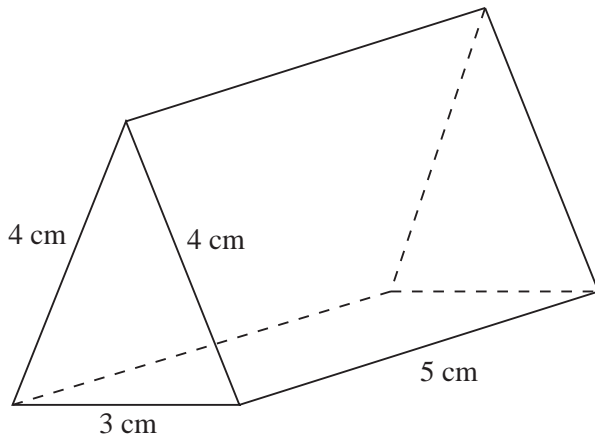

6.3 Plans and Elevations

1.

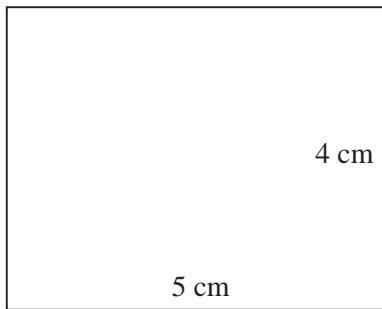

Plan

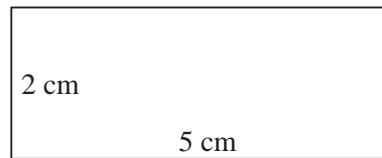

Front Elevation

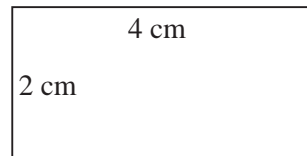

Side Elevation

2.

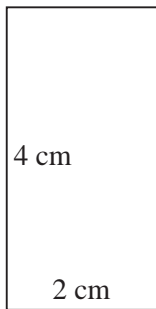

Plan

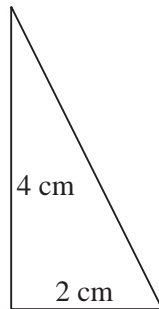

Front Elevation

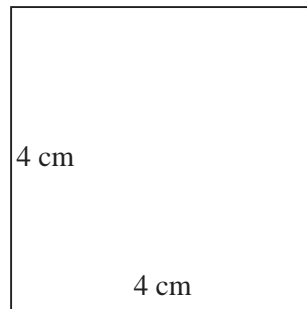

Side Elevation

3.

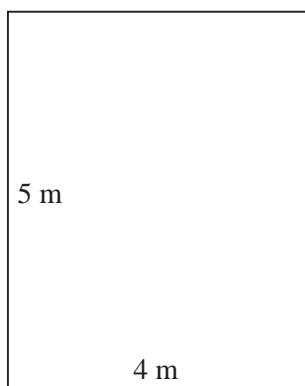

Plan

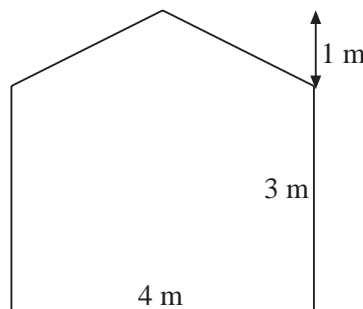

Front Elevation

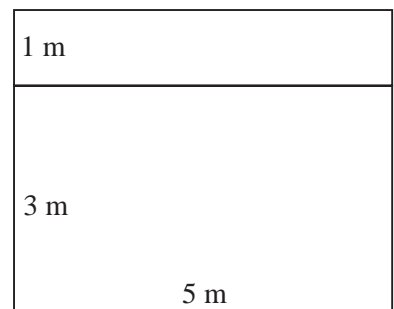

Side Elevation

6.3

Answers

4. (a)

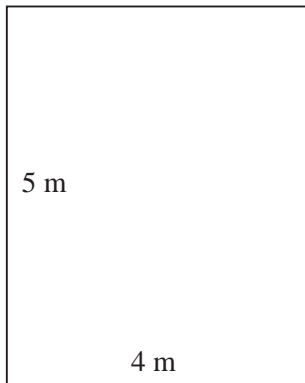

Plan

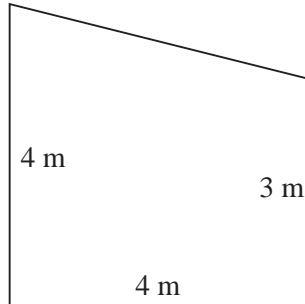

Front Elevation

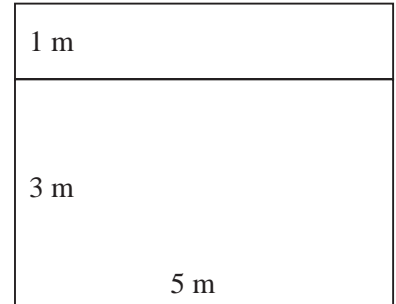

Right Side Elevation

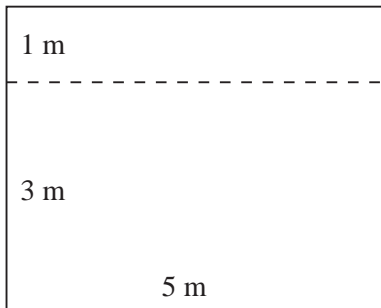

Left Side Elevation

(b) These views are very similar to those in Example 2.
Plan and side elevations are the same, but not the front elevation.

5.

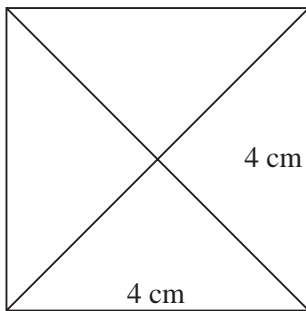

Plan

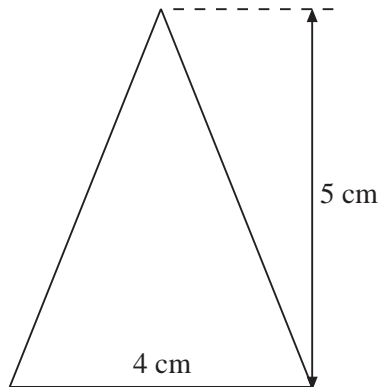

Side Elevation

6.

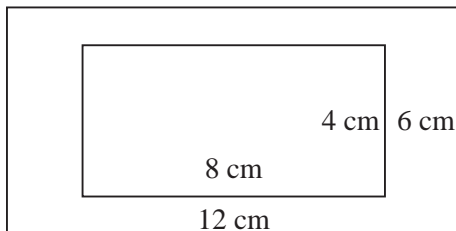

Plan

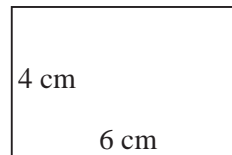

Side Elevation

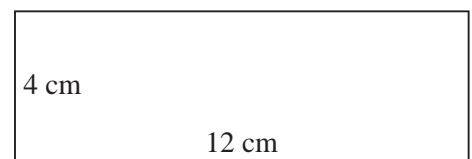

Front Elevation

6.3

Answers

7.

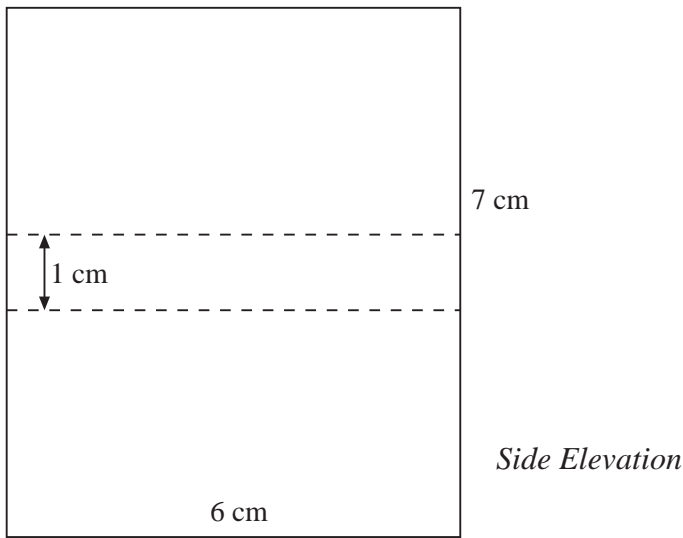
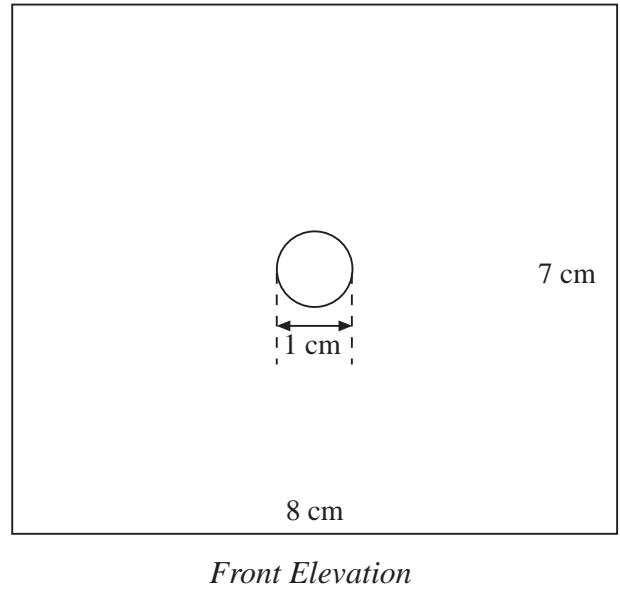
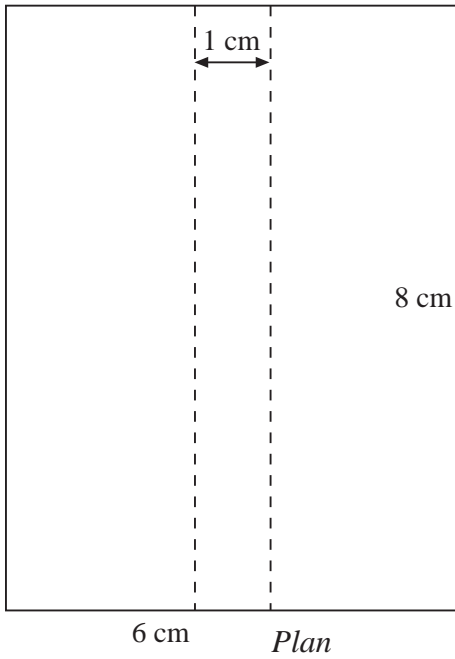

8.

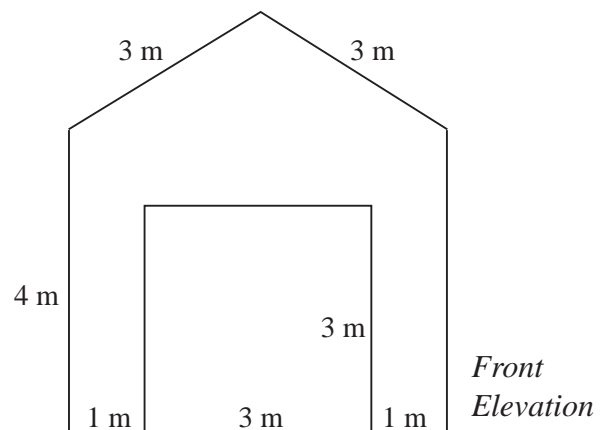
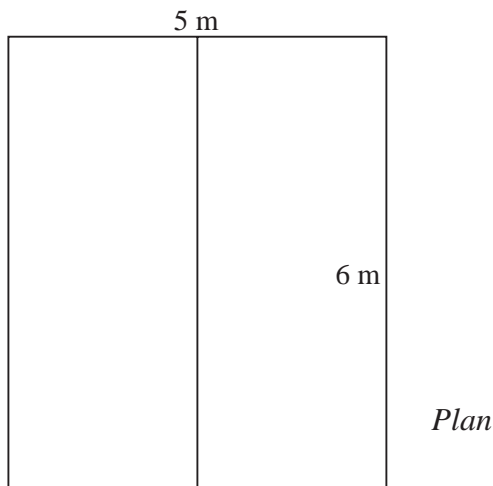

6.3

Answers

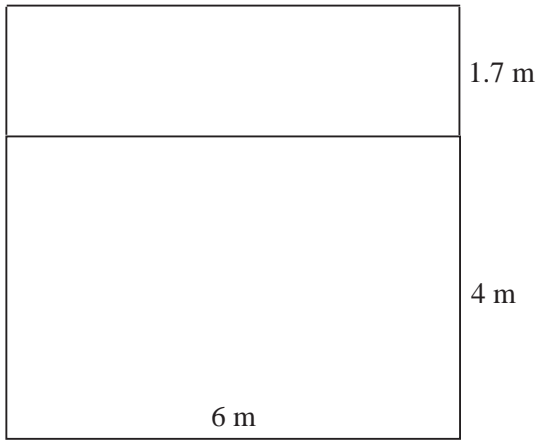

Side Elevation

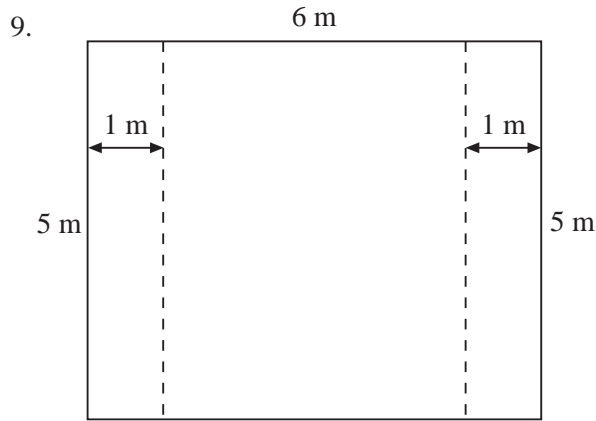

Plan

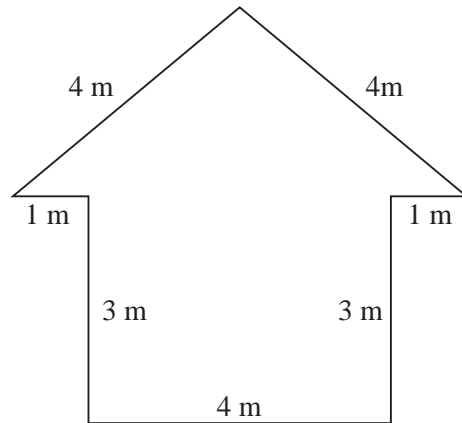

Front Elevation

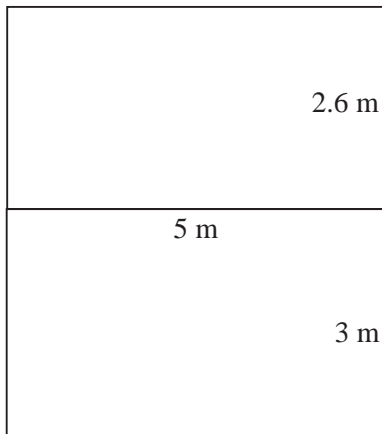

Side Elevation

6.3

Answers

10.



Plan

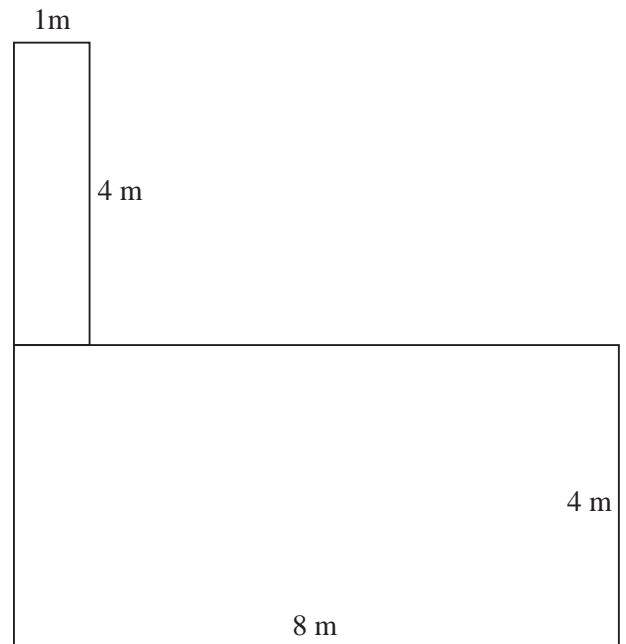

Front Elevation

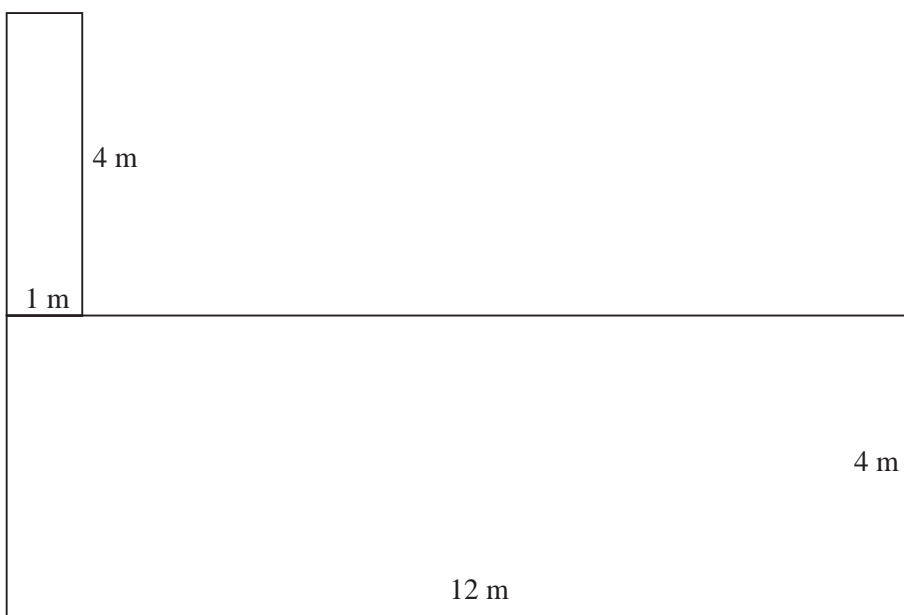

Side Elevation

Answers

6.4 Nets and Surface Area of Cubes and Cuboids

1. The following nets *can* each be folded to form a cube:

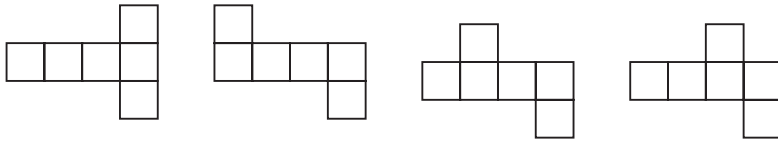

The following net *cannot* be folded to form a cube:



2.

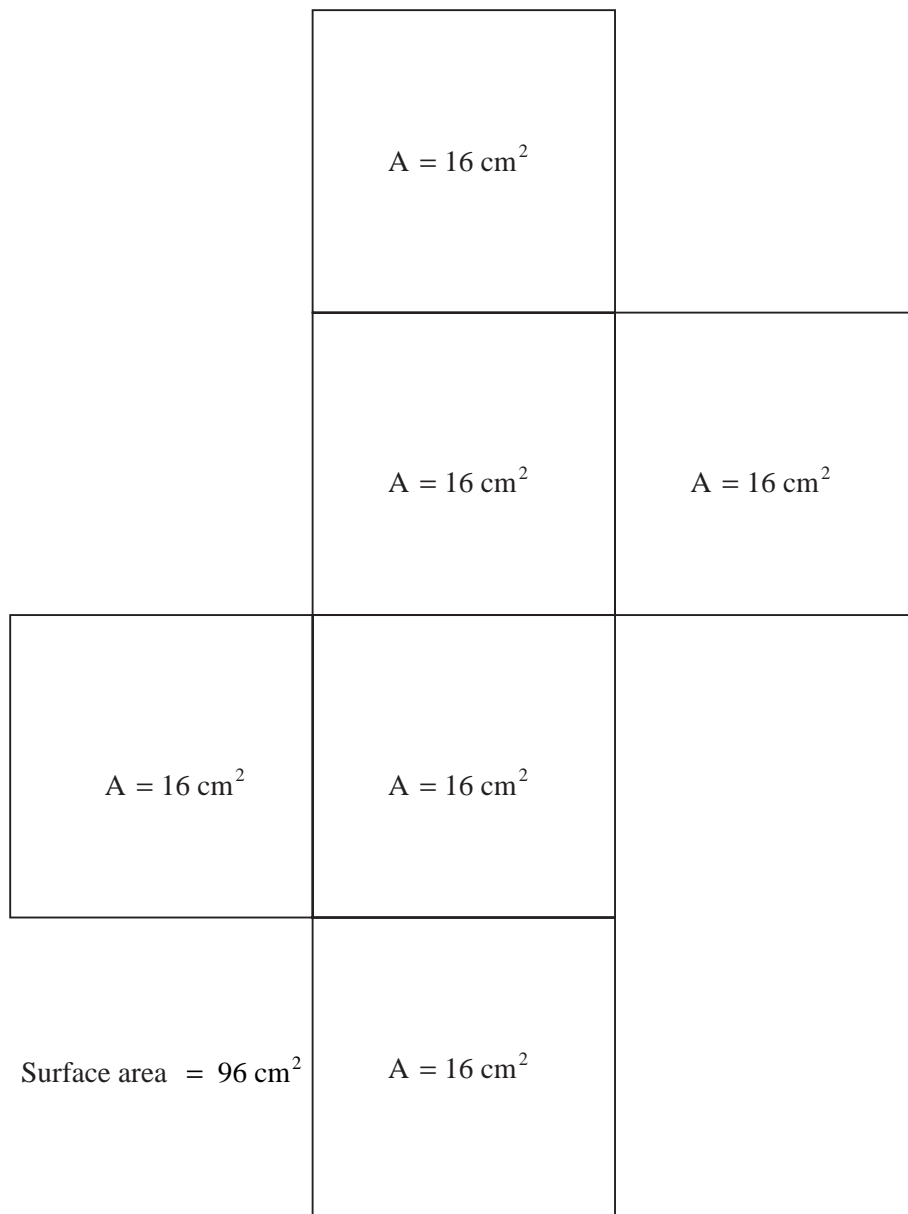

6.4

Answers

3.

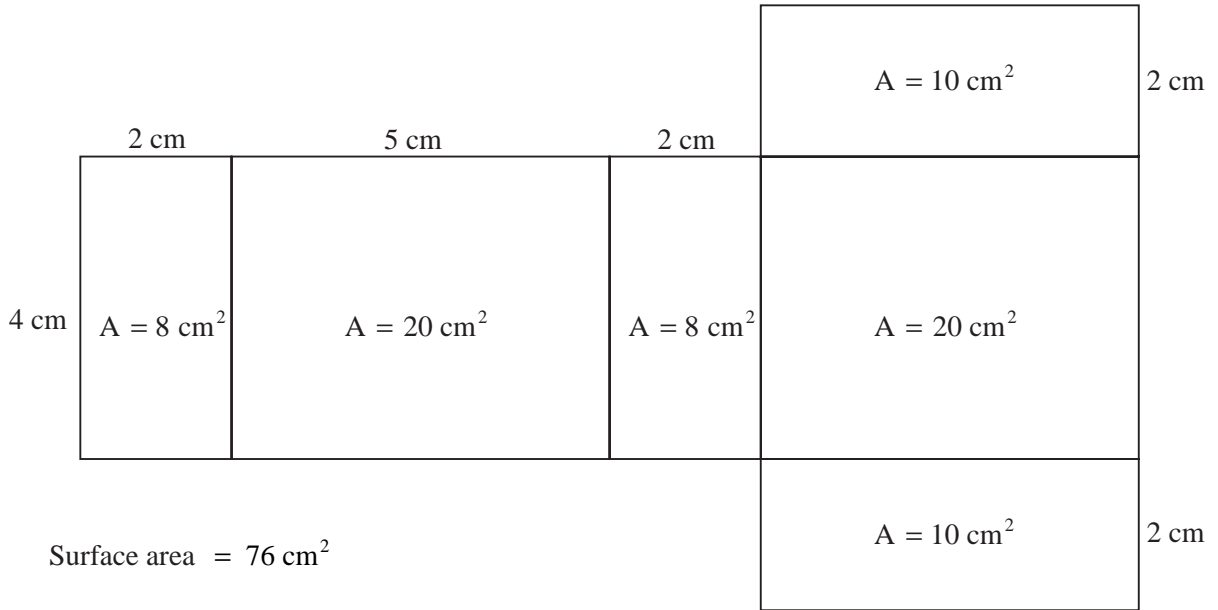

6. (a) Two possible nets:

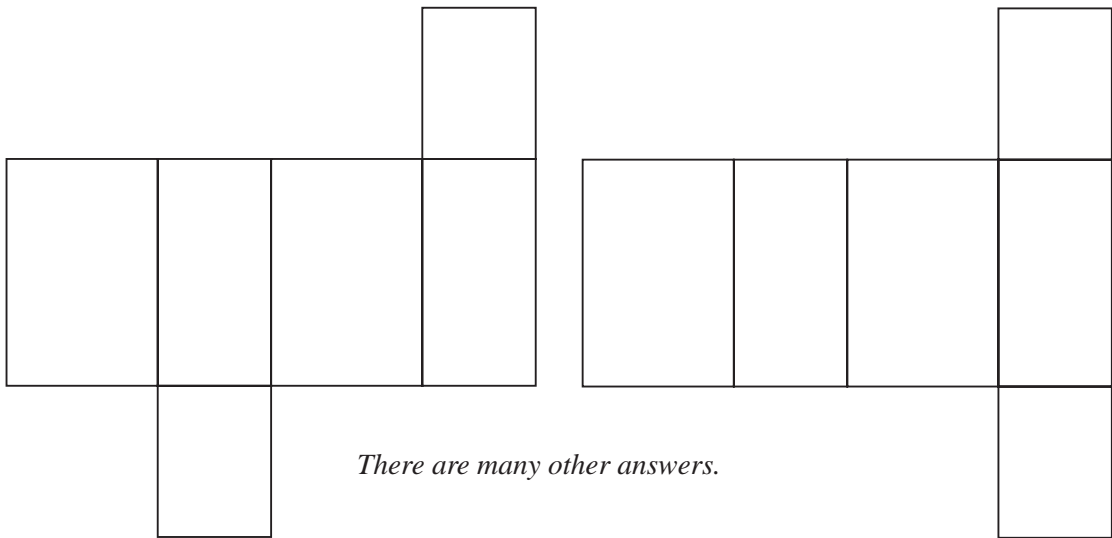

(b) $A = 108 \text{ cm}^2$

(c) Yes

7. (a) $A = 600 \text{ cm}^2$

(b) $A = 486 \text{ cm}^2$

8. (a) 72 cm^2

(b) 36 cm^2

(c) 1370 m^2

(d) 23.5 m^2

6.4

Answers

9. (a) Two side rectangles wrong size *or* two largest rectangles wrong size.

(b)

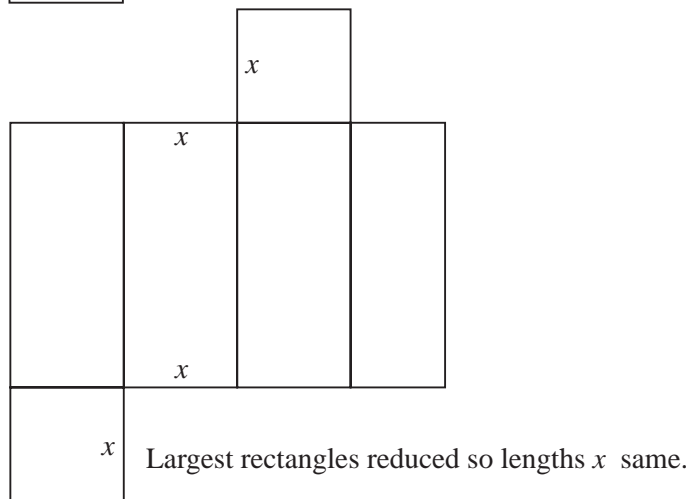
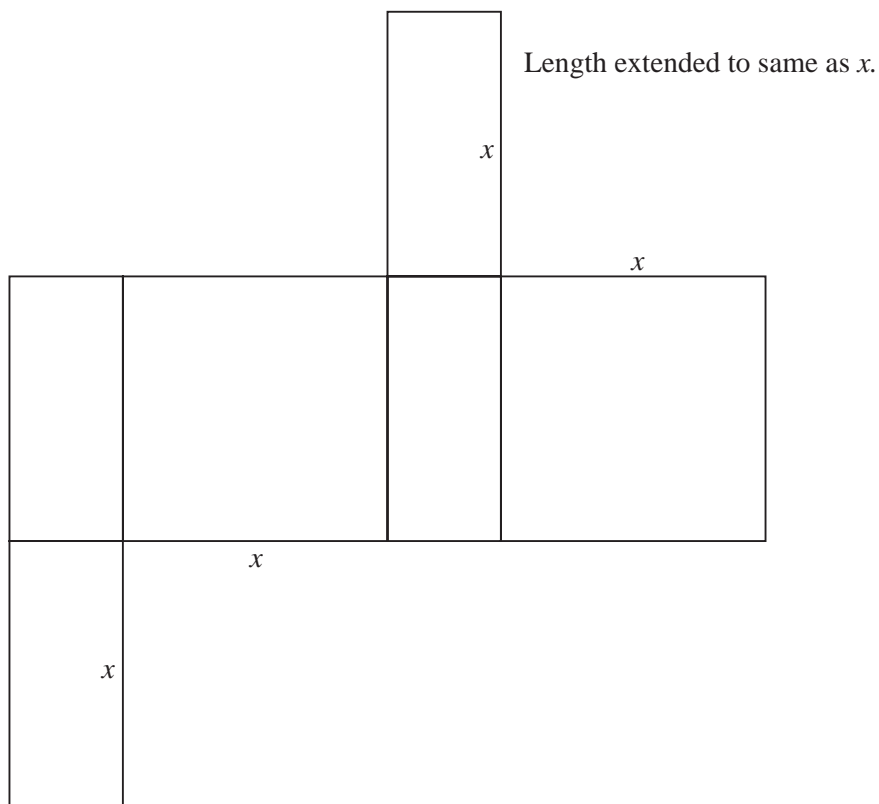

There are other possible answers.

10. Length of sides = 2 cm

11. $x = 5$ cm

Answers

6.5 Nets of Prisms and Pyramids

1.

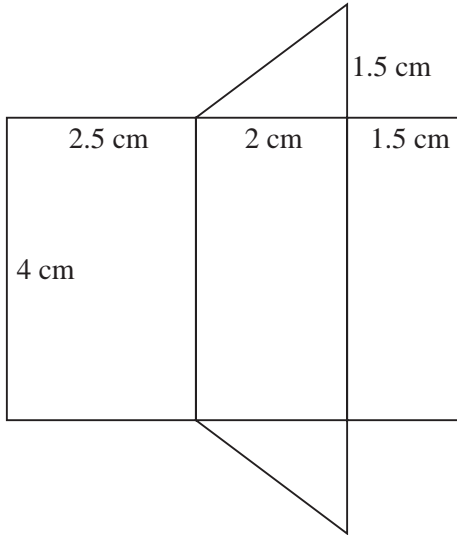

3.

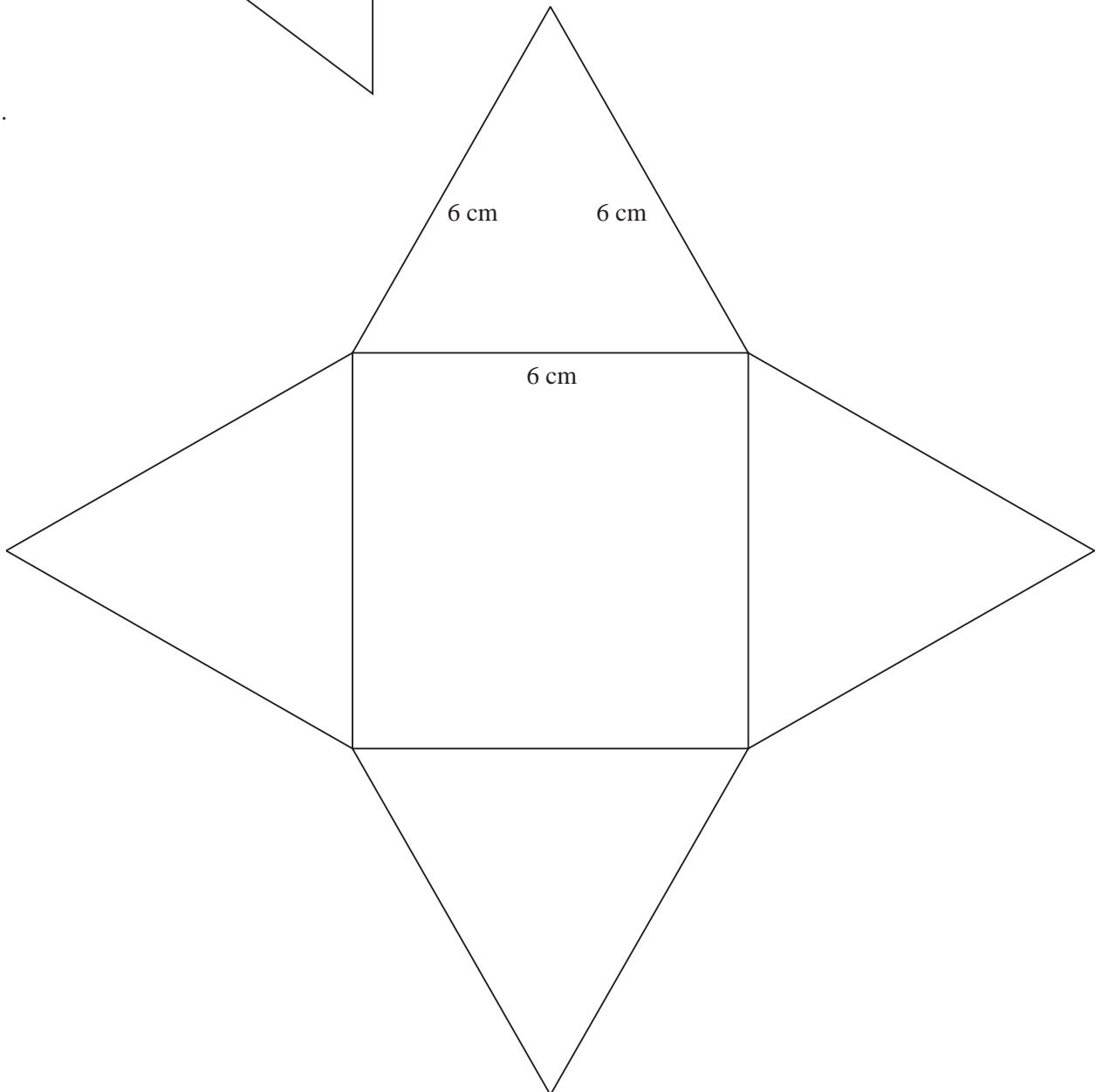

6.5

Answers

5.

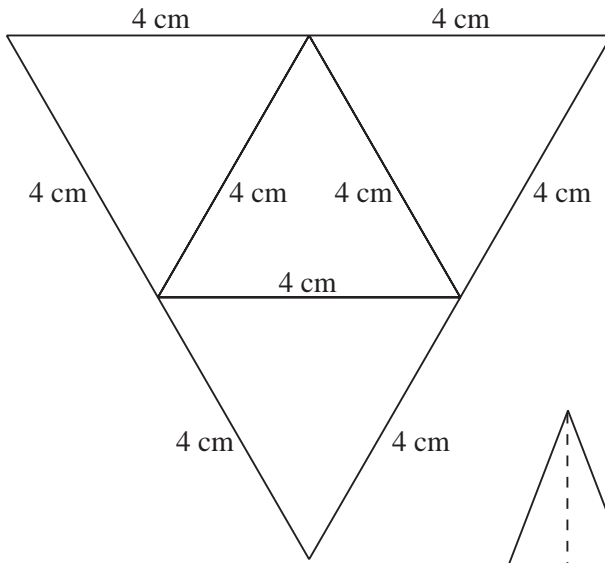

6.

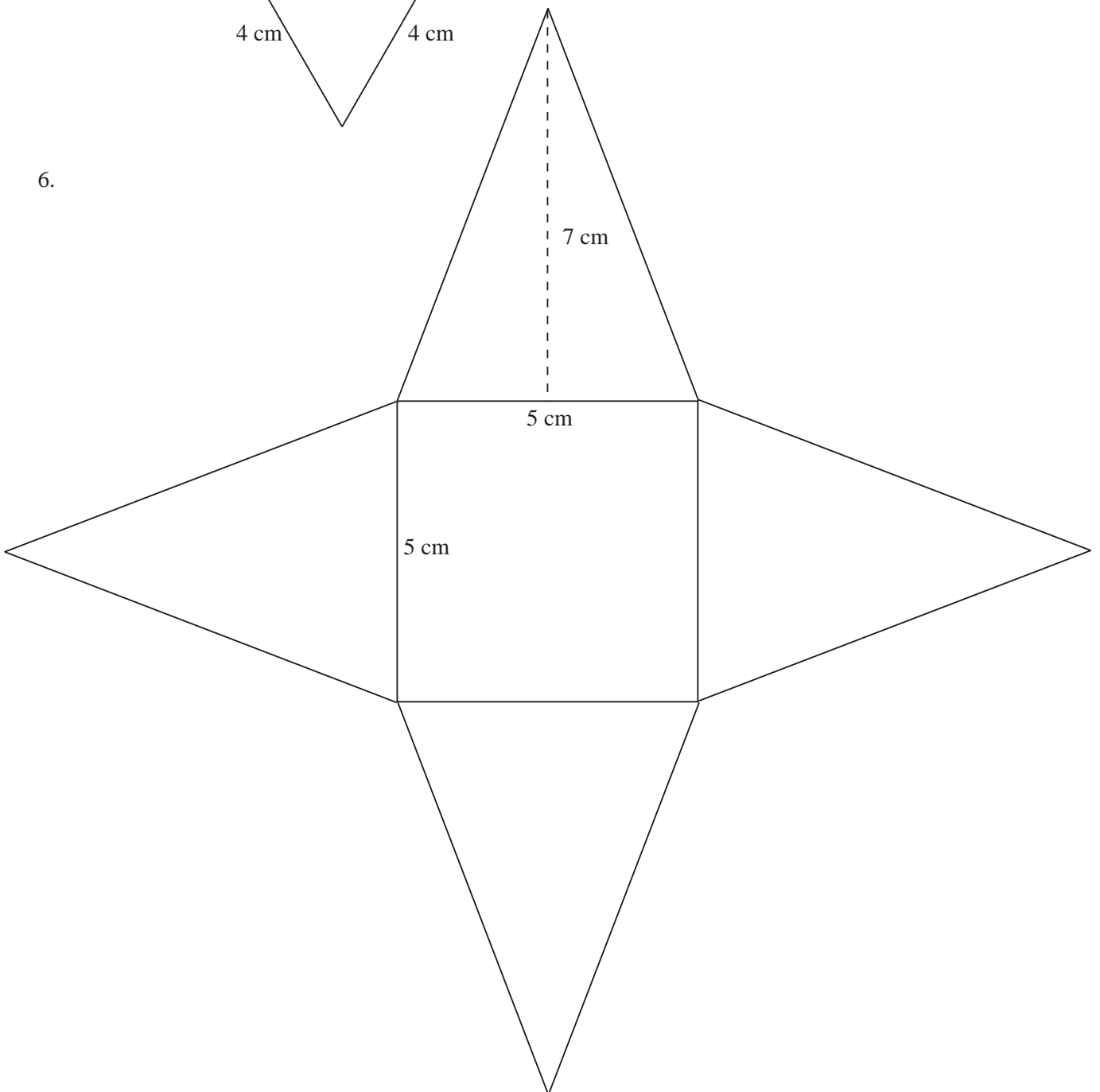

6.5

Answers

7. (a)

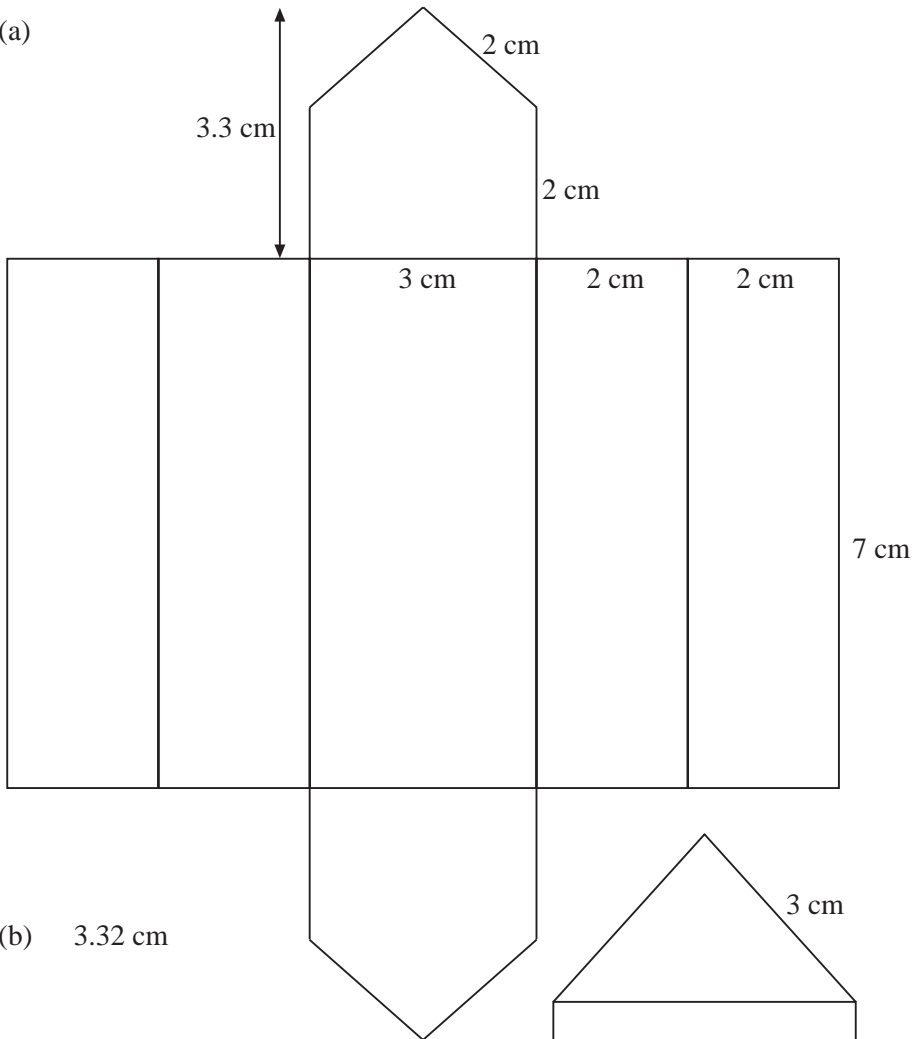

(b) 3.32 cm

8.

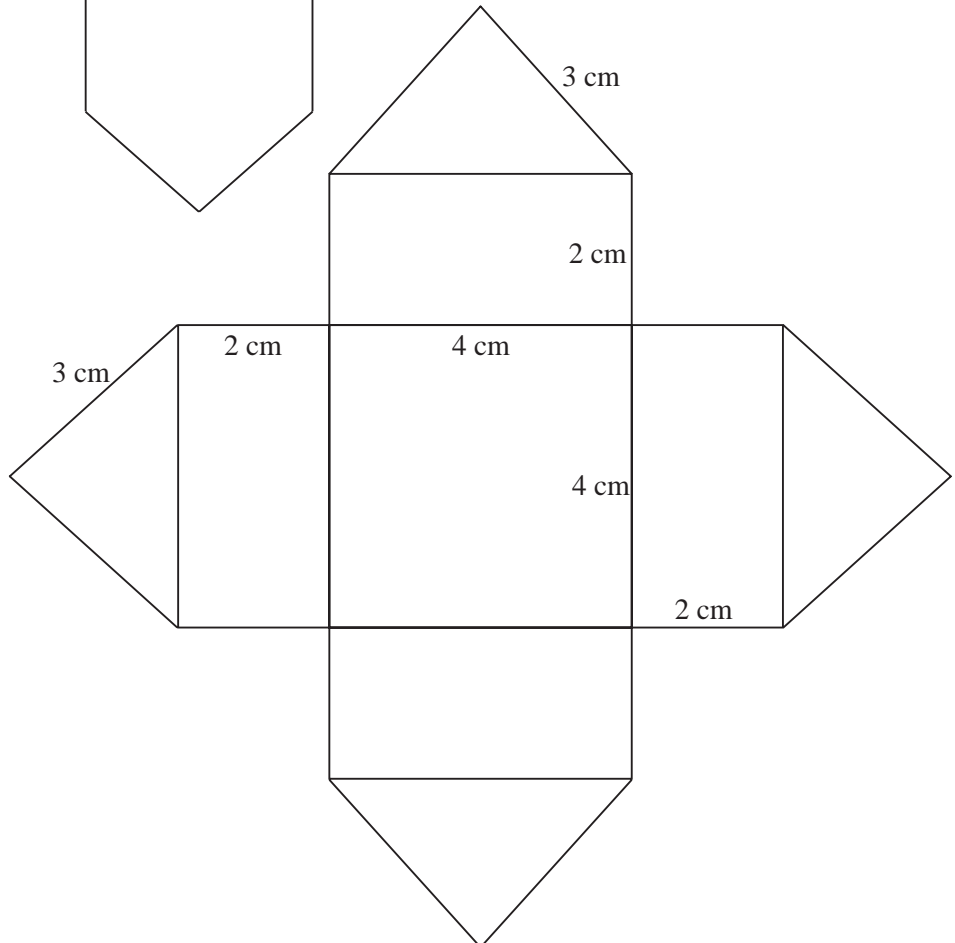

6.5

Answers

9.

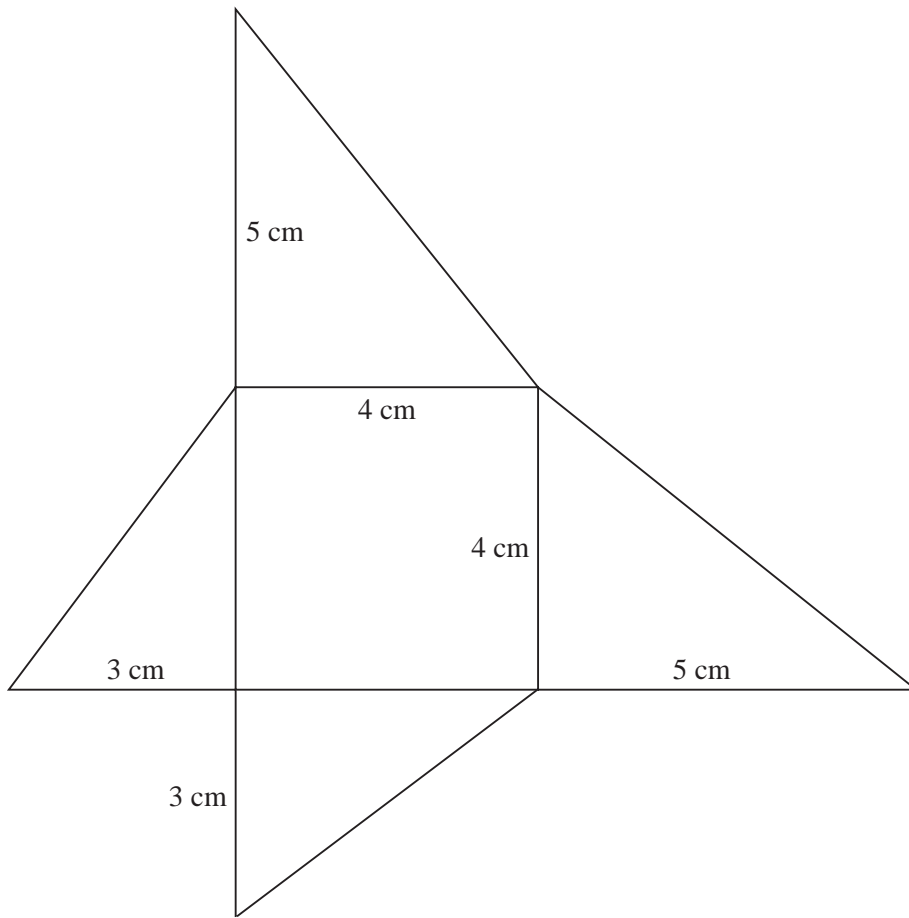

Practice Book *UNIT 7 Ratio and Proportion*

Answers

7.1 Equivalent Ratios

1. (a) 1 : 3 (b) 1 : 5 (c) 1 : 5 (d) 3 : 1
 (e) 6 : 1 (f) 6 : 5 (g) 2 : 3 (h) 1 : 4
 (i) 1 : 5 (j) 4 : 5 (k) 3 : 4 (l) 2 : 7
2. (a) 1 : 2.5 (b) 1 : 0.6 (c) 1 : 3.5 (d) 1 : 8.5
 (e) 1 : 2.5 (f) 1 : 2.5 (g) 1 : 1.5 (h) 1 : 0.8
 (i) 1 : 2.4
3. (a) 8 : 1 (b) 0.8 : 1 (c) 0.7 : 1
 (d) 7.5 : 1 (e) 3.6 : 1 (f) 1.2 : 1
4. $600 : 900 = 2 : 3$
5. (a) 2 : 5 (b) 1 : 2.5 (c) 0.4 : 1
6. (a) 3 : 8 (b) 1 : 2.67 or $1 : 2\frac{2}{3}$ (c) 0.375 : 1
7. (a) 4 : 85 (b) 1 : 21.25
8. (a) 1 km (b) 4.5 km (c) 15 km
9. 1 cm on map = 2 km. 60 km = 30 cm on map.
10. 1 cm on map = 3 km. Scale = 1 : 300 000

7.2 Direct Proportion

1. (a) £48 (b) £72 (c) £160
2. (a) 1000 ml or 1 litre (b) 1400 ml or 1.4 litres
3. (a) £3.28 (b) £9.84 (c) £24.60
4. (a) 1200 grams or 1.2 kg (b) 4200 grams or 4.2 kg
 (c) 14 400 grams or 14.4 kg
5. (a) 28p (b) 48p (c) £2.00
6. (a) £8.64 (b) 72p per m
7. (a) $n = 55$ (b) £7.15
8. 48 people
9. 378 people
10. 6570 kg

Answers

7.3 Proportional Division

- (a) £20 : £30 (b) £20 : £80 (c) £44 : £16 (d) 20 kg : 60 kg
- (a) £30 : £25 : £5 (b) £27 : £36 : £45 (c) 5 kg : 10 kg : 15 kg
(d) 36 litres : 24 litres : 15 litres
- £32 : £48
- 36 ml : 180 ml (acid : water)
- 15 ml : 25 ml (blue : yellow)
- £100 : £110 : £90
- (a) 35 ml : 25 ml : 20 ml (b) 437.5 ml : 312.5 ml : 250 ml
- (a) 50 ml : 50 ml : 100 ml (b) 75 ml : 75 ml : 50 ml
(c) 112.5 ml : 50 ml : 37.5 ml
- £400 : £50 : £350
- 5 : 15 : 5

7.4 Linear Conversion

- (a) 54 Ff (b) 900 Ff (c) £9 (d) £3.11 (nearest pence)
- (a) 150 mm (b) 2000 mm (c) 2 inches (d) 40 inches
- (a) £5 (b) £0.40 (c) 11 shillings (d) 15 shillings
- (a) 2250 grams (b) 4050 grams (c) 4 lbs (d) 7 lbs (e) 0.6 lb
- (a) 48 km (b) 33.6 km (c) 50 miles (d) 125 miles
- (a) £61.35 (b) £153.37 (c) £46.01
- (a) £5.08 (b) £1.02 (c) £253.81
- (a) 0.9 lb (b) 0.4 lb (c) 10.7 oz
- (a) £285.71 (b) £6.38 (c) 3.57 DM
- (a) 6.8 litres (b) 35.2 pints

Answers

7.5 Inverse Proportion

- (a) 5 hours (b) 6 hours (c) 7.5 hours
- Time at 50 mph = 8.4 hours (8 hours 24 mins)
Time at 70 mph = 6 hours (6 hours 0 mins)
Time saved = 2 hours 24 mins
- Time at 30 mph = 2 hours (2 hours 0 mins)
Time at 40 mph = 1.5 hours (1 hour 30 mins)
Time saved = 30 mins
- Time on own = 20 mins
Time with Jennifer = 15 mins
Time saved = 5 mins
- (a) 15 mins (b) 10 mins (c) 6 mins
- (a) 15 mins (b) $1\frac{1}{2}$ hours (c) $1\frac{2}{3}$ hours (1 hour 40 mins)
- Normal speed = 60 mph
Increased speed = 67.5 mph
Speed increase = 7.5 mph
- Speed on Monday = 4 mph. Speed on Tuesday = 3 mph.
- (a) 0.5 kg (b) 0.1 kg less (0.4 kg each)
- (a) 4 hours (b) $13\frac{1}{3}$ hours = 13 hours 20 mins

Practice Book *UNIT 8 Algebra: Brackets*

Answers

8.1 Expansion of Single Brackets

1. (a) 11 (b) -8 (c) -11 (d) 15
 (e) -7 (f) 24 (g) -56 (h) -22
 (i) -12 (j) -35 (k) 49 (l) 44

2. (a)

| | | |
|---|------|---|
| × | x | 2 |
| 4 | $4x$ | 8 |

$$4(x + 2) = 4x + 8$$

| | | |
|---|------|-----|
| × | x | -7 |
| 5 | $5x$ | -35 |

$$5(x - 7) = 5x - 35$$

| | | |
|---|------|----|
| × | x | 3 |
| 4 | $4x$ | 12 |

$$4(x + 3) = 4x + 12$$

| | | |
|---|-------|----|
| × | $2x$ | 5 |
| 5 | $10x$ | 25 |

$$5(2x + 5) = 10x + 25$$

3. (a) $4x + 24$ (b) $3x - 12$ (c) $10x + 30$ (d) $21x - 28$
 (e) $6x + 12$ (f) $24x - 72$ (g) $-2x + 8$ (h) $-24 + 6x$
 (i) $15x - 20$ (j) $18x + 72$

4. $3(4x - 8) = 12x - 24$ Whole bracket is multiplied out each time.

5. (a)

| | | |
|-----|-------|-------|
| × | x | -2 |
| x | x^2 | $-2x$ |

$$x(x - 2) = x^2 - 2xy$$

| | | |
|-----|-------|-------|
| × | x | $-y$ |
| x | x^2 | $-xy$ |

$$x(x - y) = x^2 - xy$$

6. (a) $4x(x + 8) = 4x^2 + 32$ (b) $(-3)(2x - 7) = -6x - 42x$
 (c) $4x(x - 9) = 4x^2 - 36x$ (d) $6x(x - 7) = 6x^2 - 42x$
 (e) $3x(x - y) = 3x^2 - 3xy$ (f) $-4x(2x + 8) = -8x^2 - 32x$
7. (a) $x^2 - 7x$ (b) $8x - 2x^2$ (c) $6x^2 + 12x$ (d) $12x^2 - 20x$
 (e) $x^2 + xy$ (f) $4xy - 3x^2$ (g) $4x^2 + 6xy$ (h) $10xy - 5x$
8. (a) $2(x + 4)$ (b) $12(x - 5)$ (c) $2x(x + 9)$ (d) $2x(5 + x)$
 $= 2x + 8$ $= 12x - 60$ $= 2x^2 + 18x$ $= 10x + 2x^2$
 (e) $2x(3x + 2)$ (f) $4x(6 - 2x)$
 $= 6x^2 + 4x$ $= 24x - 8x^2$
9. (a) $\frac{1}{2} \times x \times (x + 2)$ (b) $\frac{1}{2}x^2 + x$

8.1

Answers

10. (a) $2x \times 2x \times (3x - 5)$ (b) $12x^3 - 20x^2$

8.2 Linear Equations

1. (a) $x = 1$ (b) $x = 16$ (c) $x = -1$ (d) $x = 2$
(e) $x = 2.5$ or $\frac{5}{2}$ (f) $x = 7\frac{2}{3}$ or $\frac{23}{3}$ (g) $x = 6.4$ or $\frac{32}{5}$ (h) $x = 1.2$ or $\frac{6}{5}$

2. (a) $x = 4.3$ or $\frac{43}{10}$ (b) $x = 1$ (c) $x = 4.5$ or $\frac{9}{2}$ (d) $x = 7.5$ or $\frac{15}{2}$

3. $3(x + 4) = 18 \Rightarrow x = 2$

4. (a) $5(x + 7) = 55$ (b) $x = 4$

5. (a) $4(x + 6) = 17$ (b) $x = -1.75$ or $-\frac{7}{4}$

6. (a) $x = 2$ (b) $x = 4$ (c) $x = 1$ (d) $x = 1$
(e) $x = 0.5$ or $\frac{1}{2}$ (f) $x = 1\frac{2}{3}$ or $\frac{5}{3}$

7. $5(11 - x) = 45 \Rightarrow x = 2$

8. (a) $x = 5$ (b) $x = \frac{3}{2}$ or $1\frac{1}{2}$ (c) $x = 1.2$ or $\frac{6}{5}$ (d) $x = 2$

9. (a) $\text{Area} = \frac{1}{2} \times 3 \times (x + 4) = \frac{3}{2}(x + 4)$ (b) $x = 6$

8.3 Common Factors

1. (a) $2(x + 2)$ (b) $5(x + 3)$ (c) $6(x + 3)$
(d) $5(x - 5)$ (e) $3(x - 7)$ (f) $7(x + 5)$
(g) $3(3x - 4)$ (h) $5(3x + 4)$ (i) $3(14x + 5)$

2. (a) $x(3x + 2)$ (b) $5(x^2 + 2)$ (c) $3x(2 - x)$
(d) $2x(3x - 2)$ (e) $7x(3x + 2)$ (f) $5x(3 - 5x)$

3. (a) Yes (b) by 'taking out' a 2, giving $4x + 6x^2 = 2x(2 + 3x)$

4. (a) Yes (b) No; $3x(x + 3)$ (c) No; $5x(1 - 6x)$
(d) No; $8x(x - 4)$ (e) No; $6x(x - 3)$ (f) No; $3x(5 - 2x)$

8.3

Answers

5. The '3' has not been 'taken out' of the 24. Factorisation should be $3x(5 + 8x)$.
6. (a) $x(y + z)$ (b) $yz(x + 3)$ (c) $4q(p - 2r)$
 (d) $5xy(z + 4u)$ (e) $y(5x - 4p)$ (f) $x(7y + 12z)$
7. (a) $xy(x + y)$ (b) $3xy^2(x + 2)$ (c) $5xy(x - 7)$
 (d) $2xy(11 + 2y)$ (e) $xyz(x + y)$ (f) $x^2(y - xz)$
 (g) $xy^2(x^5 + y)$ (h) $x^2y^3(x^2 + y^3)$
8. (a) $x^2 + xy + xz$ (b) $x(5x + 2y + 4z)$
9. (a) $3(x + 3y + 6z)$ (b) $2x(2x + 1 + 4y)$ (c) $3x(2 - y + 4z)$
 (d) $5x(z + 4 - 7y)$ (e) $7x(x + 2y - 3y^2)$ (f) $x(4 + 6z + 15y)$
10. (a) $x^2(4y + 12xy^2 + 1)$ (b) $x^4y(6x^3y - 4x - y)$
 (c) $xy(3xy - 4y^2 + x^3)$ (d) $x^2(5x^5y - y^3 + 4xz)$

8.4 Expansion of Two Brackets

1. (a)
- | | | |
|-----|-------|------|
| × | x | 5 |
| x | x^2 | $5x$ |
| 4 | $4x$ | 20 |
- $$(x + 4)(x + 5)$$
- $$= x^2 + 9x + 20$$
- | | | |
|-----|-------|-------|
| × | x | -7 |
| x | x^2 | $-7x$ |
| 4 | $4x$ | -28 |
- $$(x + 4)(x - 7)$$
- $$= x^2 - 3x - 28$$
- | | | |
|------|-------|------|
| × | x | 4 |
| x | x^2 | $4x$ |
| -1 | $-x$ | -4 |
- $$(x + 4)(x - 1)$$
- $$= x^2 + 3x - 4$$
- | | | |
|------|-------|-------|
| × | x | -5 |
| x | x^2 | $-5x$ |
| -2 | $-2x$ | 10 |
- $$(x - 5)(x - 2)$$
- $$= x^2 - 7x + 10$$

2. (a) $x^2 + 7x + 12$ (b) $x^2 + 3x - 10$ (c) $x^2 - 6x + 5$
 (d) $x^2 + 4x - 21$ (e) $x^2 - x - 6$ (f) $x^2 + 3x - 4$
3. (a) $x^2 - 1$ (b) $x^2 - 4$ (c) $x^2 - 25$ (d) $x^2 - 49$; no x terms.

8.4

Answers

4. $(x + 5)^2 = (x + 5)(x + 5) = x^2 + 10x + 25$; statement has no x terms.

5. (a) $x^2 + 2x + 1$ (b) $x^2 - 2x + 1$ (c) $x^2 + 6x + 9$ (d) $x^2 - 10x + 25$

6. (a)

| | | |
|----------|--------|-------|
| \times | x | 6 |
| $2x$ | $2x^2$ | $12x$ |
| 1 | x | 6 |

(b) $2x^2 + 13x + 6$

7. (a) $4x^2 + 10x + 4$ (b) $12x^2 + 7x + 1$ (c) $6x^2 + x + 4$

(d) $20x^2 - x - 1$ (e) $4x^2 + 4x + 1$ (f) $16x^2 - 24x + 9$

8. (a) $13x$ (b) $12x$ (c) $-7x$

(d) -1 (e) $2x^2$ (f) $-14x$

9. $(x + 4)(x - 5) = x^2 - x - 20$; no x terms in original statement.

10. (a) 2 (b) 6 (c) 3, 9 (d) 7, 35

(e) 2, 2 (f) 4, 2 or 2, 4

11. (a) $x^4 + 4x^3 + 6x^2 + 4x + 1$ (b) $x^5 + 5x^4 + 10x^3 + 10x^2 + 5x + 1$

Coefficients are the numbers in the 2nd, 3rd, 4th and 5th rows of Pascal's Triangle for $(x + 1)^2$, $(x + 1)^3$, $(x + 1)^4$ and $(x + 1)^5$ respectively.

Practice Book *UNIT 9 Fractions and Percentages* Answers

9.1 Revision of Operations with Fractions

1. (a) $\frac{5}{7}$ (b) $\frac{5}{4}$ or $1\frac{1}{4}$ (c) $\frac{8}{9}$ (d) $\frac{2}{5}$ (e) $\frac{16}{13}$ or $1\frac{3}{13}$
 (f) $\frac{11}{7}$ or $1\frac{4}{7}$ (g) $\frac{2}{7}$ (h) $\frac{1}{3}$ (i) $\frac{5}{13}$
2. (a) $\frac{5}{6}$ (b) $\frac{12}{35}$ (c) $\frac{9}{20}$ (d) $\frac{7}{6}$ or $1\frac{1}{6}$ (e) $\frac{47}{40}$ or $1\frac{7}{40}$
 (f) $\frac{31}{20}$ or $1\frac{11}{20}$ (g) $\frac{23}{21}$ or $1\frac{2}{21}$ (h) $\frac{10}{9}$ or $1\frac{1}{9}$ (i) $\frac{7}{8}$
3. (a) 4 (b) 8 (c) $5\frac{4}{5}$ (d) $4\frac{5}{6}$ (e) $6\frac{2}{5}$ (f) $9\frac{1}{7}$
 (g) $7\frac{3}{8}$ (h) $7\frac{13}{21}$ (i) $6\frac{2}{9}$
4. (a) 1 (b) $1\frac{1}{2}$ (c) $\frac{1}{8}$ (d) $\frac{6}{7}$ (e) $\frac{14}{8}$ or $1\frac{3}{4}$
 (f) $\frac{5}{6}$ (g) $1\frac{5}{9}$ (h) $\frac{41}{14}$ or $2\frac{13}{14}$ (i) $\frac{19}{12}$ or $1\frac{7}{12}$
5. (a) £5 (b) 6 kg (c) £24 (d) 72 kg
 (e) 35 kg (f) 7.5 m (g) £21.60 (h) 29.4 m
6. (a) $\frac{1}{8}$ (b) $\frac{3}{40}$ (c) $\frac{2}{5}$ (d) $\frac{4}{7}$ (e) $\frac{3}{5}$ (f) $\frac{12}{35}$
 (g) $\frac{3}{8}$ (h) $\frac{4}{21}$ (i) $\frac{1}{10}$
7. (a) $\frac{3}{2}$ (b) $\frac{27}{32}$ (c) $\frac{3}{4}$ (d) $\frac{7}{5}$ or $1\frac{2}{5}$ (e) $\frac{5}{4}$ or $1\frac{1}{4}$
 (f) $\frac{40}{63}$ (g) $\frac{9}{7}$ or $1\frac{2}{7}$ (h) $\frac{16}{21}$ (i) $\frac{5}{4}$
8. (a) $\frac{9}{8}$ or $1\frac{1}{8}$ (b) 1 (c) $\frac{5}{6}$ (d) $\frac{3}{8}$ (e) $\frac{15}{8}$ or $1\frac{7}{8}$ (f) $\frac{4}{3}$ or $1\frac{1}{3}$
9. (a) 2 (b) 7 (c) $\frac{27}{8}$ or $3\frac{3}{8}$
 (d) 14 (e) $\frac{45}{8}$ or $5\frac{5}{8}$ (f) $\frac{39}{8}$ or $4\frac{7}{8}$

9.1

Answers

10. (a) $\frac{9}{8}$ or $1\frac{1}{8}$ (b) $\frac{11}{2}$ or $5\frac{1}{2}$ (c) $\frac{16}{9}$ or $1\frac{7}{9}$
11. (a) $\frac{5}{2}$ or $2\frac{1}{2}$ (b) $\frac{14}{5}$ or $2\frac{4}{5}$ (c) $\frac{7}{3}$ or $2\frac{1}{3}$
12. (a) $\frac{65}{28}$ or $2\frac{9}{28}$ (b) $\frac{15}{14}$ or $1\frac{1}{14}$ (c) $\frac{25}{12}$ or $2\frac{1}{12}$ (d) $\frac{7}{2}$ or $3\frac{1}{2}$
- (e) 4 (f) $\frac{25}{24}$ or $1\frac{1}{24}$

9.2 Fractions in Context

1. (a) $\frac{19}{28}$ (b) $\frac{8}{21}$ (c) $6\frac{3}{4}$ (d) 3 (e) $\frac{21}{32}$ (f) $\frac{3}{10}$
- (g) $10\frac{1}{2}$ (h) $1\frac{7}{8}$ (i) $6\frac{8}{21}$ (j) $\frac{9}{10}$ (k) $8\frac{1}{3}$ (l) $2\frac{1}{10}$
2. (a) Converts to fraction in simplest form.
 (b) Converts to mixed number in simplest form.
 (c) $\frac{3}{7}$ same; $\frac{9}{2} \rightarrow 4\frac{1}{2}$; $\frac{4}{6} \rightarrow \frac{2}{3}$;
 $\frac{6}{4} \rightarrow 1\frac{1}{2}$; $\frac{10}{3} \rightarrow 3\frac{1}{3}$; $\frac{3}{10}$ same
3. (a) Area = $\frac{1}{3}$ m², perimeter = $2\frac{1}{3}$ m (b) Area = $3\frac{1}{4}$ m², perimeter = $7\frac{7}{10}$ m
4. 320 pupils
5. (a) 5 discs (b) 4 discs (c) 100 discs
6. (a) 8 cakes (b) 16 cakes (c) 1 cake ($1\frac{7}{9}$) (d) 2 cakes ($2\frac{2}{3}$)
 (e) 4 cakes (f) 3 cakes ($3\frac{5}{7}$)
7. $x = \frac{52}{15}$ or $3\frac{7}{15}$
8. (a) $\frac{1}{2}$ cm (b) $1\frac{1}{2}$ cm (c) $\frac{7}{8}$ cm (d) $1\frac{3}{4}$ cm
- 360 sheets in pile of paper $4\frac{1}{2}$ cm high

9.2

Answers

9. 280 drinks

$$10. \text{ Volume} = \frac{21}{5} \times \frac{27}{8} \times \frac{11}{4} = 38\frac{157}{160} \text{ cm}^3$$

9.3 Conversion of Fractions and Percentages

1. (a) $\frac{1}{2}$ (b) $\frac{3}{4}$ (c) $\frac{2}{5}$ (d) $\frac{1}{4}$ (e) $\frac{1}{5}$ (f) $\frac{1}{10}$

(g) $\frac{2}{25}$ (h) $\frac{29}{50}$ (i) $\frac{9}{25}$ (j) $\frac{16}{25}$ (k) $\frac{19}{25}$ (l) $\frac{3}{25}$

2. (a) 70% (b) 50% (c) 25% (d) 75% (e) 35% (f) 24%

(g) 95% (h) 68% (i) 60% (j) 20% (k) 55% (l) 14%

3. (a) $\frac{1}{8}$ (b) $\frac{2}{3}$ (c) $\frac{1}{3}$ (d) $\frac{29}{200}$ (e) $\frac{37}{200}$ (f) $\frac{17}{400}$

4. (a) $12\frac{1}{2}\%$ (b) $16\frac{2}{3}\%$ (c) $37\frac{1}{2}\%$

(d) $23\frac{1}{2}\%$ (e) $30\frac{1}{2}\%$ (f) $66\frac{2}{3}\%$

5. 32%

6. 40%

7. $62\frac{1}{2}\%$

8. (a) 25% (b) 75%

9. (a) $33\frac{1}{3}\%$ (b) $66\frac{2}{3}\%$

10. (a) Science 75%; Maths 75%; English 76%; French 70%

(b) Average 74%

Answers

9.4 Finding Percentages

- (a) £11 (b) 7 m (c) £15 (d) 24 m (e) £24 (f) 45 kg
(g) £22.50 (h) $1\frac{1}{2}$ kg (i) 9.6 kg (j) £6.40 (k) 5.6 m (l) £7
- (a) £35 (b) £52.50 (c) £7 (d) £5.25 (e) £4.90 (f) £6.65
- (a) £4.375 (b) To the nearest pence £4.38
- (a) £2.63 (b) £13.13 (c) £1.23 (all to the nearest pence)
- £18
- (a) £157.50 (b) £1057.50
- 48
- (a) £62 (b) £124
- 238 pupils
- 42 marks

9.5 Increasing and Decreasing Quantities by a Percentage

- (a) £44 (b) £149.60 (c) £288.20
- (a) £40 (b) £73.60 (c) £272
- (a) 52 m (b) £63 (c) £79.20 (d) 112 kg (e) £1300
(f) £45 (g) 66.5 kg (h) £76.50 (i) 42.8 m (j) £18.72
- £480
- | | | |
|-------------------|-------|-------|
| Box of chocolates | £3.12 | £3.12 |
| Flour | £0.78 | 78p |
| Sweets | £0.52 | 52p |
| Beans | £0.21 | 21p |
| Drink | £0.47 | 47p |
- £67.50
- £192

9.5

Answers

8. (a) £470 (b) £25.85 (c) 76.38
9. 126 000 people
10. (a) End 1st year $800 \times 1.05 = \text{£}840$
End 2nd year $840 \times 1.05 = \text{£}882$
(b) £1021.03 (nearest pence)
11. (a) 1.1 (b) $1.1 \times 1.1 = 1.21$ (c) 1.1^n (d) 8 years

9.6 Finding the Percentage Increase and Decrease

- 10%
- 20%
- 3%
- 25% (note that this is profit of 20p on selling price of 80p)
- 15%
- 6% (nearest %)
- $18.75\% = 18.8\%$ (1 d.p.)
- 27.3% (3 s.f.)
- 1.33% (3 s.f.)
- (a) 5% (b) 7.00% (2 d.p.) (c) 12.35% (2 d.p.)

9.7 Reverse Percentage Calculations

- Jeans £45
Coat £70
Shirt £17.50
- £12 000
- 43p

9.7

Answers

4. 450 gm
5. £25
6. 22 cm
7. £21 000
8. £165.71 (nearest pence)
9. 14 cm
10. £1885.71 (nearest pence)

Practice Book *UNIT 10 Probability - Two Events* **Answers**

10.1 Recap: Basic Probability for One Event

1. $p(\text{girl}) = \frac{2}{3}$
2. (a) $p(\text{red}) = \frac{1}{4}$ (b) $p(\text{blue}) = \frac{2}{5}$ (c) $p(\text{green}) = \frac{7}{20}$ (d) $p(\text{yellow}) = 0$
3. (a) $p(7) = \frac{1}{13}$ (b) $p(\text{heart}) = \frac{1}{4}$ (c) $p(\text{red}) = \frac{1}{2}$ (d) $p(\text{red } 6) = \frac{1}{26}$
4. (a) $p(5) = \frac{1}{6}$ (b) $p(\text{odd}) = \frac{1}{2}$ (c) $p(>1) = \frac{5}{6}$ (d) $p(\text{multiple of } 4) = \frac{1}{6}$
5. (a) $p(\text{even}) = \frac{1}{2}$ (b) $p(\text{multiple of } 4) = \frac{1}{5}$ (c) $p(<7) = \frac{7}{10}$ (d) $p(\text{multiple of } 5) = \frac{1}{10}$
6. (a) $p(\text{criminal}) = \frac{1}{10}$ (b) $p(\text{not criminal}) = \frac{9}{10}$
7. $p(\text{girl}) = \frac{17}{35}$
8. (a) $p(\text{£1}) = \frac{3}{16}$ (b) $p(2p) = \frac{1}{2}$ (c) $p(\text{not £1 coin}) = \frac{13}{16}$ (d) $p(\text{£1 or } 10p) = \frac{1}{2}$
9. (a) (i) $p(W) = \frac{2}{17}$ (ii) $p(S \text{ or } T) = \frac{5}{17}$ (iii) $p(J \text{ or } M) = \frac{3}{17}$
 (iv) $p(\text{not } H) = \frac{15}{17}$ (v) $p(\text{vowel}) = \frac{4}{17}$ (b) S
10. (a) $p(\text{favourite}) = \frac{1}{11}$ (b) $p(\text{like}) = \frac{8}{11}$ (c) $p(\text{not like}) = \frac{2}{11}$

10.2 Outcomes with Two Events

1.

| | | | |
|---------------|----------|---------------|-----------|
| | | <i>COIN B</i> | |
| | | <i>H</i> | <i>T</i> |
| <i>COIN A</i> | <i>H</i> | <i>HH</i> | <i>HT</i> |
| | <i>T</i> | <i>TH</i> | <i>TT</i> |

| | | | | | | |
|------------------|----------|------------------|----------|----------|----------|----------|
| | | <i>SPINNER B</i> | | | | |
| | | <i>1</i> | <i>2</i> | <i>3</i> | <i>4</i> | |
| <i>SPINNER A</i> | <i>S</i> | <i>1</i> | <i>2</i> | <i>3</i> | <i>4</i> | <i>5</i> |
| | <i>P</i> | <i>2</i> | <i>3</i> | <i>4</i> | <i>5</i> | <i>6</i> |
| | <i>N</i> | <i>3</i> | <i>4</i> | <i>5</i> | <i>6</i> | <i>7</i> |
| | <i>R</i> | <i>4</i> | <i>5</i> | <i>6</i> | <i>7</i> | <i>8</i> |

2. (a) diagram opposite
- (b) 16
- (c) 4

10.2

Answers

3. (a)

| | | DICE A | | | | | |
|---------------------------|----|--------|----|----|----|---|---|
| | | -2 | -1 | 0 | 1 | 2 | 3 |
| D I C E B | -2 | -4 | -3 | -2 | -1 | 0 | 1 |
| | -1 | -3 | -2 | -1 | 0 | 1 | 2 |
| | 0 | -2 | -1 | 0 | 1 | 2 | 3 |
| | 1 | -1 | 0 | 1 | 2 | 3 | 4 |
| | 2 | 0 | 1 | 2 | 3 | 4 | 5 |
| 3 | 1 | 2 | 3 | 4 | 5 | 6 | |

(b) 5

4. (a)

| | | SPINNER A | | | | |
|--------------------------------------|---|-----------|---|---|---|---|
| | | 1 | 2 | 3 | 4 | 5 |
| S P I N N E R B | 1 | 2 | 3 | 4 | 5 | 6 |
| | 2 | 3 | 4 | 5 | 6 | 7 |
| | 3 | 4 | 5 | 6 | 7 | 8 |

(b) 15

(c) 3

5. (a)

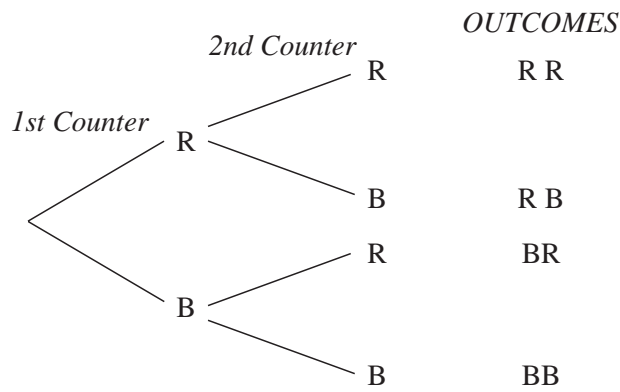

(b) 3

(c) 3

6. (a) and (b)

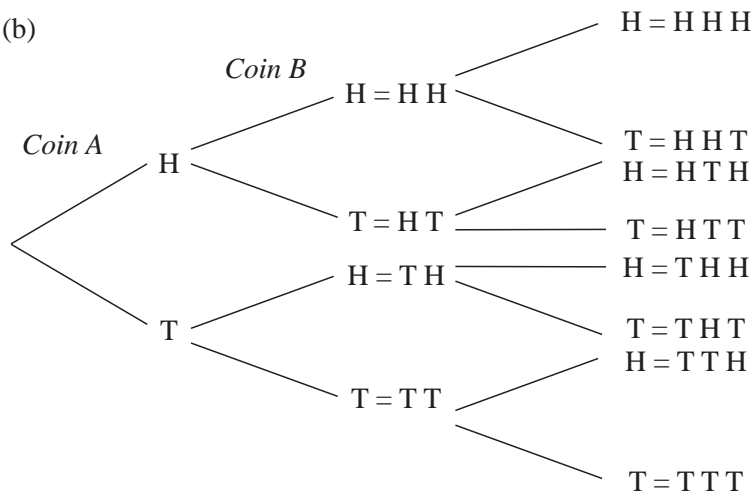

(c) 8

(d) 16

10.2

Answers

7. (a)

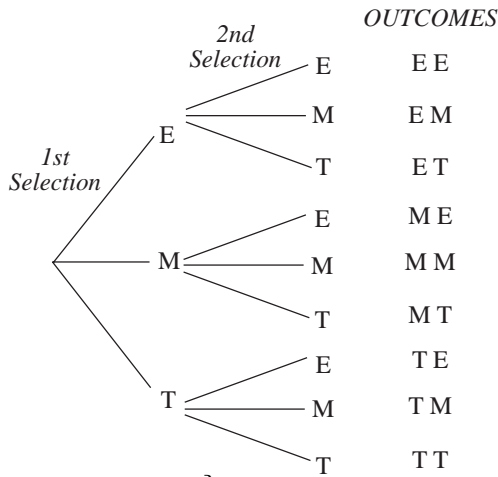

(b) 5

(c) 2

8. (a) $\left. \begin{array}{l} \text{Red} \quad 1 - 6 \\ \text{Blue} \quad 1 - 6 \\ \text{Green} \quad 1 - 6 \end{array} \right\} \text{ total} = 18 \text{ possible outcomes}$

(b) 3

9. (a)

| | | DICE A | | | | | |
|-----------------------|---|--------|----|----|----|----|----|
| | | 1 | 2 | 3 | 4 | 5 | 6 |
| D I C E B | 1 | 1 | 2 | 3 | 4 | 5 | 6 |
| | 2 | 2 | 4 | 6 | 8 | 10 | 12 |
| | 3 | 3 | 6 | 9 | 12 | 15 | 18 |
| | 4 | 4 | 8 | 12 | 16 | 20 | 24 |
| | 5 | 5 | 10 | 15 | 20 | 25 | 30 |
| | 6 | 6 | 12 | 18 | 24 | 30 | 36 |

(b) 4

(c) 2

10. (a) RRR, RRG, RRW, RGG, RGW, RWG, RWW, RGR, RWR
 GGG, GGR, GGW, GRR, GRW, GWR, GWW, GRG, GWG
 WWW, WWR, WWG, WRR, WRG, WGR, WGG, WRW, WGW

(b) 19

(c) 26

(d) 12

10.3 Probability Using Listings

1. (a) $p(9) = \frac{1}{9}$ (b) $p(\text{odd}) = \frac{1}{2}$ (c) $p(> 10) = \frac{1}{12}$ (d) $p(< 8) = \frac{7}{12}$

2.

| | 1 | 3 | 5 | 7 |
|---|---|---|---|----|
| 1 | 2 | 4 | 6 | 8 |
| 2 | 3 | 5 | 7 | 9 |
| 3 | 4 | 6 | 8 | 10 |
| 4 | 5 | 7 | 9 | 11 |

(a) $p(7) = \frac{1}{8}$

(b) $p(6) = \frac{1}{8}$

(c) $p(> 10) = \frac{1}{16}$

(d) $p(< 5) = \frac{1}{4}$

10.3

Answers

3.

| | | | | | | | |
|----------------------------|----------|-------------|----------|----------|----------|----------|----------|
| | | <i>DICE</i> | | | | | |
| | | <i>1</i> | <i>2</i> | <i>3</i> | <i>4</i> | <i>5</i> | <i>6</i> |
| <i>C O I N</i> | <i>H</i> | H 1 | H 2 | H 3 | H 4 | H 5 | H 6 |
| | <i>T</i> | T 1 | T 2 | T 3 | T 4 | T 5 | T 6 |

(a) $p(H + 3) = \frac{1}{12}$

(b) $p(T + \text{even}) = \frac{1}{4}$

(c) $p(H + \text{prime}) = \frac{1}{4}$

4. (a)

| | | | |
|---|----|----|----|
| | R | B | Y |
| R | RR | RB | RY |
| B | BR | BB | BY |
| G | GR | GB | GY |

(b) $p(\text{same colour}) = \frac{2}{9}$

(c) $p(Y + R) = \frac{1}{9}$

(d) $p(R + B) = \frac{2}{9}$

5.

| | | | | |
|-----------|----------|----------|----------|----------|
| | <i>1</i> | <i>2</i> | <i>3</i> | <i>4</i> |
| <i>-1</i> | 0 | 1 | 2 | 3 |
| <i>0</i> | 1 | 2 | 3 | 4 |
| <i>1</i> | 2 | 3 | 4 | 5 |
| <i>2</i> | 3 | 4 | 5 | 6 |

(a) $p(6) = \frac{1}{16}$

(b) $p(0) = \frac{1}{16}$

(c) $p(1) = \frac{1}{8}$

(d) $p(3) = \frac{1}{4}$

6. (a) $p(\text{even}) = \frac{1}{2}$ (b) $p(> 1) = \frac{13}{16}$ (c) $p(< 1) = \frac{1}{16}$ (d) $p(< 6) = \frac{15}{16}$

7. (a) $p(\text{at least 1 head}) = \frac{3}{4}$ (b) $p(\text{no head}) = \frac{1}{4}$

8.

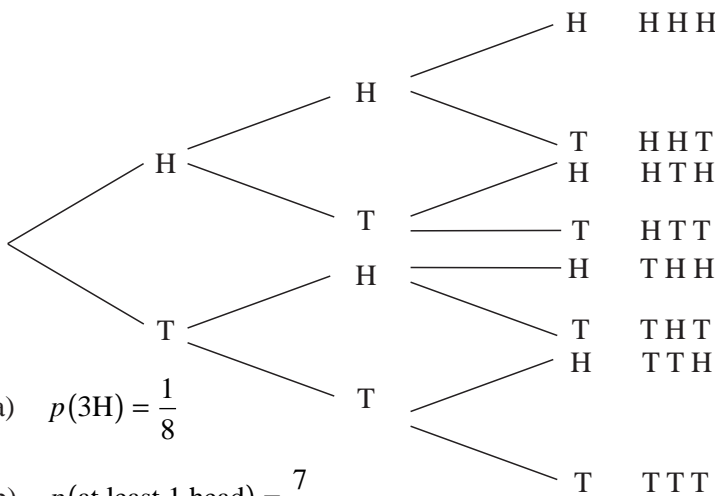

(a) $p(3H) = \frac{1}{8}$

(b) $p(\text{at least 1 head}) = \frac{7}{8}$

(c) $p(\text{at least 2 heads}) = \frac{1}{2}$

10.3

Answers

9.

| | 1 | 2 | 3 | 4 | 5 | 6 |
|---|---|----|----|----|----|----|
| 1 | 1 | 2 | 3 | 4 | 5 | 6 |
| 2 | 2 | 4 | 6 | 8 | 10 | 12 |
| 3 | 3 | 6 | 9 | 12 | 15 | 18 |
| 4 | 4 | 8 | 12 | 16 | 20 | 24 |
| 5 | 5 | 10 | 15 | 20 | 25 | 30 |
| 6 | 6 | 12 | 18 | 24 | 30 | 36 |

(a) $p(12) = \frac{1}{9}$

(b) $p(20) = \frac{1}{18}$

(c) $p(>25) = \frac{1}{12}$

(d) $p(<30) = \frac{11}{12}$

(e) $p(\text{even}) = \frac{3}{4}$

10. $p(\text{same no. H and T}) = \frac{3}{8}$

10.4 Multiplication Law for Independent Events

1. (a) $p(\text{R and R}) = \frac{9}{25}$ (b) $p(\text{R and R or B and B}) = \frac{9}{25} + \frac{4}{25}$
 $= \frac{13}{25}$

(c) $p(\text{R and R or R and B or B and R}) = \frac{9}{25} + \frac{6}{25} + \frac{6}{25}$
 $= \frac{21}{25}$

2. (a) $p(\text{R and R}) = \frac{49}{100}$ (b) $p(\text{R and R or B and B}) = \frac{49}{100} + \frac{9}{100}$
 $= \frac{58}{100}$
 $= \frac{29}{50}$

(c) $p(\text{R and R or R and B or B and R}) = \frac{49}{100} + \frac{21}{100} + \frac{21}{100}$
 $= \frac{91}{100}$

10.4

Answers

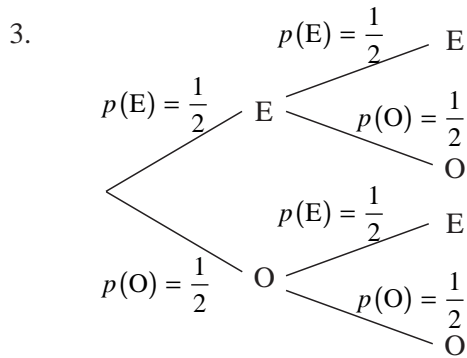

(a) $p(2E) = \frac{1}{2} \times \frac{1}{2} = \frac{1}{4}$

(b) $p(\text{at least one even number})$
 $= \left(\frac{1}{2} \times \frac{1}{2}\right) + \left(\frac{1}{2} \times \frac{1}{2}\right) + \left(\frac{1}{2} \times \frac{1}{2}\right)$
 $= \frac{3}{4}$

(c) $p(\text{no even number}) = \frac{1}{4}$

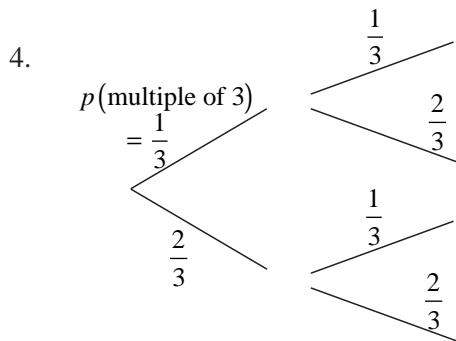

(a) $p(2 \text{ multiples of } 3) = \frac{1}{3} \times \frac{1}{3} = \frac{1}{9}$

(b) $p(1 \text{ multiple of } 3) = \left(\frac{1}{3} \times \frac{2}{3}\right) + \left(\frac{1}{3} \times \frac{2}{3}\right)$
 $= \frac{4}{9}$

(c) $p(\text{less than } 2 \text{ multiples of } 3) = 1 - \frac{1}{9} - \frac{4}{9} = \frac{4}{9}$

5. (a) $p(2 \text{ H}) = \frac{4}{25}$ (b) $p(\text{no heads}) = \frac{9}{25}$ (c) $p(\text{at least one head}) = \frac{16}{25}$

6. (a) $p(2 \text{ R}) = \frac{9}{16}$ (b) $p(\text{at least one red}) = \frac{15}{16}$ (c) $p(\text{no reds}) = \frac{1}{16}$

7. (a) $p(2 \text{ B}) = \frac{4}{25}$,

$$p(\text{at least one A}) = 1 - \frac{4}{25}$$

$$= \frac{21}{25}$$

(b) $p(\text{at least one B}) = 1 - \frac{9}{25} = \frac{16}{25}$

(c) $p(2 \text{ A}) = \frac{9}{25}$ (d) $p(2 \text{ B}) = \frac{4}{25}$

10.4

Answers

8.

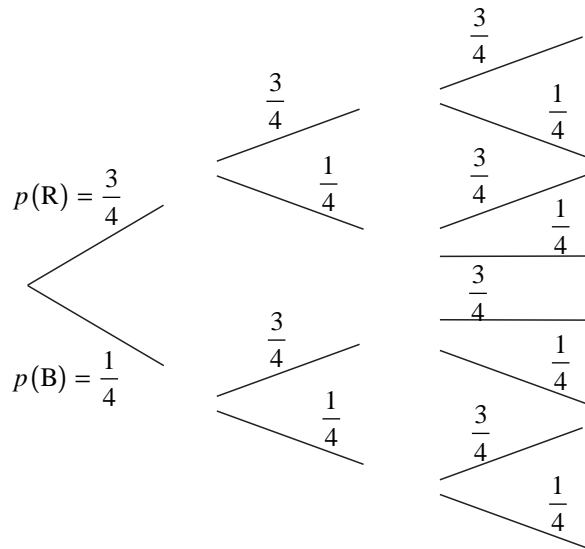

(a) $p(3 \text{ R}) = \frac{27}{64}$

(b) $p(2 \text{ R}) = 3 \times \frac{9}{64} = \frac{27}{64}$

(c) $p(\text{at least one red}) = 1 - p(3 \text{ B})$
 $= \frac{63}{64}$

9. (a) $p(\text{same colour}) = \left(\frac{1}{7}\right)^2 + \left(\frac{2}{7}\right)^2 + \left(\frac{4}{7}\right)^2 = \frac{21}{49} \quad \left(= \frac{3}{7}\right)$ (b) $p(\text{no Y}) = \frac{9}{49}$

(c) $p(\text{at least one Y}) = \frac{40}{49}$

10. (a) $p(2 \text{ no. 5s}) = \left(\frac{1}{10}\right)^2 = \frac{1}{100}$ (b) $p(2 \text{ even nos.}) = \frac{1}{2} \times \frac{1}{2} = \frac{1}{4}$

(c) $p(\text{both multiples of 3}) = \left(\frac{3}{10}\right)^2$
 $= \frac{9}{100}$

(d) $p(\text{at least one with no. greater than 2}) = \left(\frac{4}{5}\right)^2 + \left(\frac{4}{5} \times \frac{1}{5}\right) + \left(\frac{4}{5} \times \frac{1}{5}\right) = \frac{24}{25}$

11. $p(\text{both green}) = 0.5 \times 0.4 = 0.20$

12. (a) $p(3 \text{ R}) = \frac{8}{27}$ (b) $p(2 \text{ G}) = \frac{2}{9}$

13. (a) $\frac{9}{16}$ (b) $\frac{9}{64}$

14. (a) 0.24 (b) 0.144 (c) 0.36

15. $\frac{5}{12}$

Answers

10.5 Conditional Probability

1. (a) $\frac{3}{10}$ (b) $\frac{2}{5}$ (c) $1 - \frac{3}{10} = \frac{7}{10}$

2. $\frac{5}{11}$

3. (a) $\frac{5}{14}$ (b) $\frac{3}{28}$ (c) $\frac{15}{28}$

4. $\frac{13}{18}$

5. $\frac{1}{4}$

6. $\frac{5}{12}$

7. 0.32

8. 0.29

9. $\frac{9}{91}$

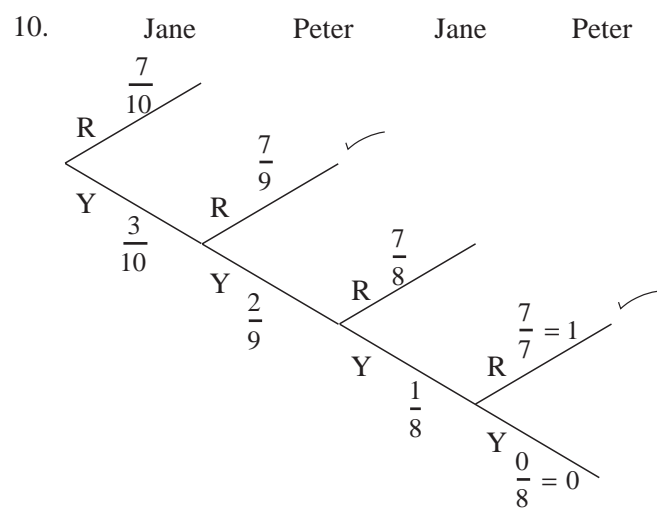

$$p(\text{Peter wins}) = \left(\frac{3}{10} \times \frac{7}{9}\right) + \left(\frac{3}{10} \times \frac{2}{9} \times \frac{1}{8}\right)$$

$$= \frac{29}{120}$$

Practice Book *UNIT 11 Angles, Bearings and Maps* Answers

11.1 Angle Measures

- (a) 45° (b) 76° (c) 20° (d) 50°
- (a) 97° (b) 143° (c) 312° (d) 186° (e) 274° (f) 120°
- (a) Obtuse (b) Reflex (c) Acute
(d) Acute (e) Reflex (f) Reflex
- (a) 40° , 39° , 101° (b) 180°
- (a) 65° , 99° , 80° , 116° (b) 360°
- Drawing
- (a) Drawing (b) 80° (c) $280^\circ + 80^\circ = 360^\circ$
- (a) $a = 34^\circ$, $b = 117^\circ$, $c = 209^\circ$ (b) $34^\circ + 117^\circ + 209^\circ = 360^\circ$
- (a) $x = 45$, $y = 135^\circ$ (b) $x + y = 180^\circ$.
- Drawing

11.2 Parallel and Intersecting Lines

- (a) c , e , g (b) d , f , h
- (a) $a = 70^\circ$, corresponding angles; $b = 110^\circ$, supplementary angles
(b) $a = 40^\circ$, alternate angles; $b = 140^\circ$, supplementary angles; $c = 140^\circ$, vertically opposite
(c) $a = 80^\circ$, supplementary angles; $b = 80^\circ$, vertically opposite;
 $c = 110^\circ$, corresponding angles; $d = 80^\circ$, corresponding or supplementary angles
(d) $a = 81^\circ$, supplementary angles; $b = 99^\circ$, vertically opposite;
 $c = 81^\circ$, supplementary angles; $d = 99^\circ$, alternate angles
- $b = 65^\circ$, $a = c = 115^\circ$
- 36° , 144° , 144°
- 133° , 47° , 47°
- $a = 100^\circ$, $b = 130^\circ$, $c = 50^\circ$, $d = 30^\circ$, $e = 150^\circ$
- (a) $b = 37^\circ$, supplementary angles; $c = 37^\circ$, alternate angles;
 $a + b + c = 180^\circ$, (angles in a triangle)
 $a = 106^\circ$
(b) Isosceles triangle
- $c = 180 - (20 + 62) = 98^\circ$ (angles in a triangle); $a = c = 98^\circ$, alternate angles;
 $b = 180 - (46 + 98) = 36^\circ$ (angles in a triangle)

11.2

Answers

9. (a) $\angle BED = 54^\circ$, supplementary angles;
 $\angle CDE = 180 - (72 + 54) = 54^\circ$, angles in a triangle;
 Since BC parallel to ED (BCDE trapezium),
 $\angle ABC = \angle BED = 54^\circ$, corresponding angles;
 $\angle ACB = \angle CDE = 54^\circ$, corresponding angles;
 $\angle CBE = \angle BCD = 126^\circ$, supplementary angles
- (b) Since $BE = CD$, we have isosceles trapezium.

11.3 Bearings

1. (a) 180° (b) 180° (c) 45° (d) 225° (e) 45°

2.

| <i>Direction</i> | <i>Bearing</i> |
|------------------|----------------|
| N | 000° |
| NE | 045° |
| W | 270° |
| SW | 225° |

3.

| <i>Location</i> | <i>Bearing</i> |
|-----------------|----------------|
| Quay | 043° |
| Beach | 133° |
| Lighthouse | 232° |
| Church | 267° |
| Mine | 309° |

4. (a) 301° (b) 121°
5. (a) 313° (b) 075° (c) 212° (d) 032°
6. $044^\circ + 180^\circ = 224^\circ$

11.3

Answers

7.

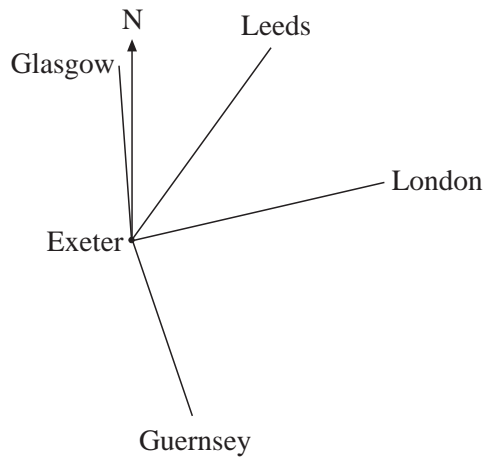

8. Sails 135° on return (SE).

- 9. (a) 000°
- (b) 340°
- (c) 135°
- (d) 315°

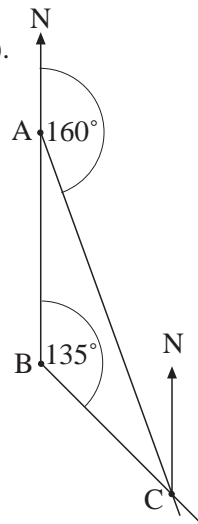

- 10. (a) 030°
- (b) 120°
- (c) 045°

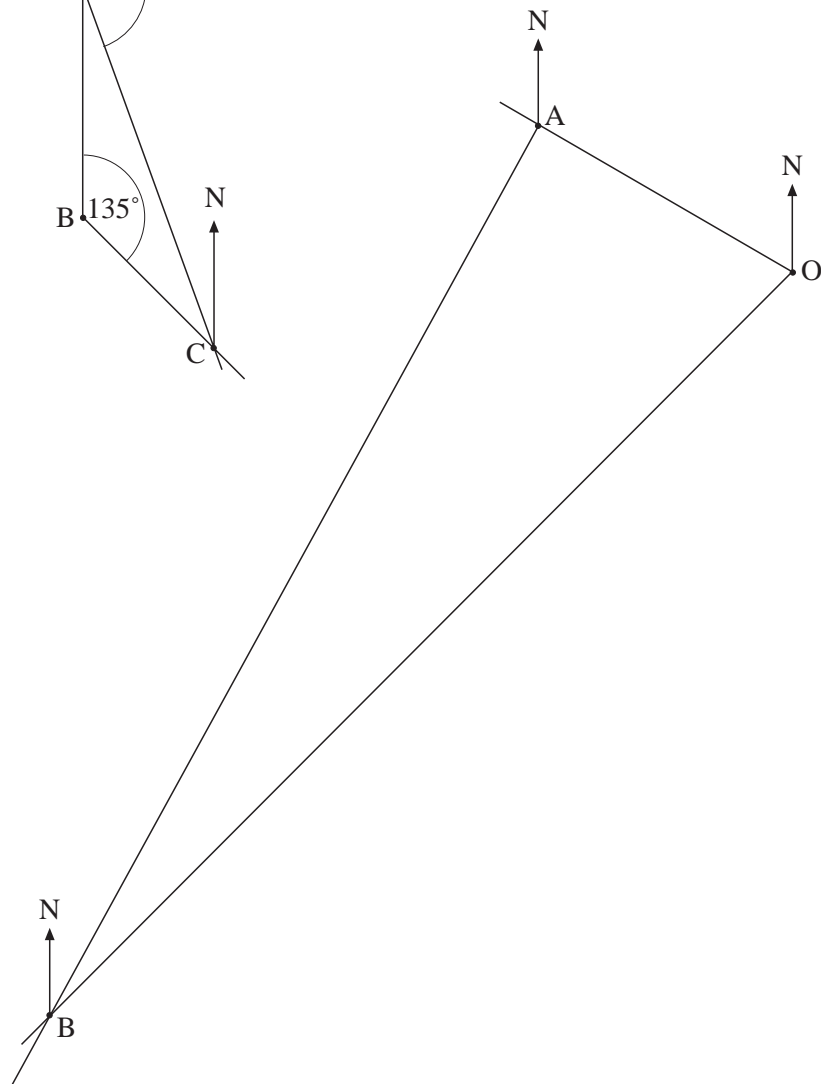

Answers

11.4 Scale Drawings

1. (a) 216

m (b) 248°

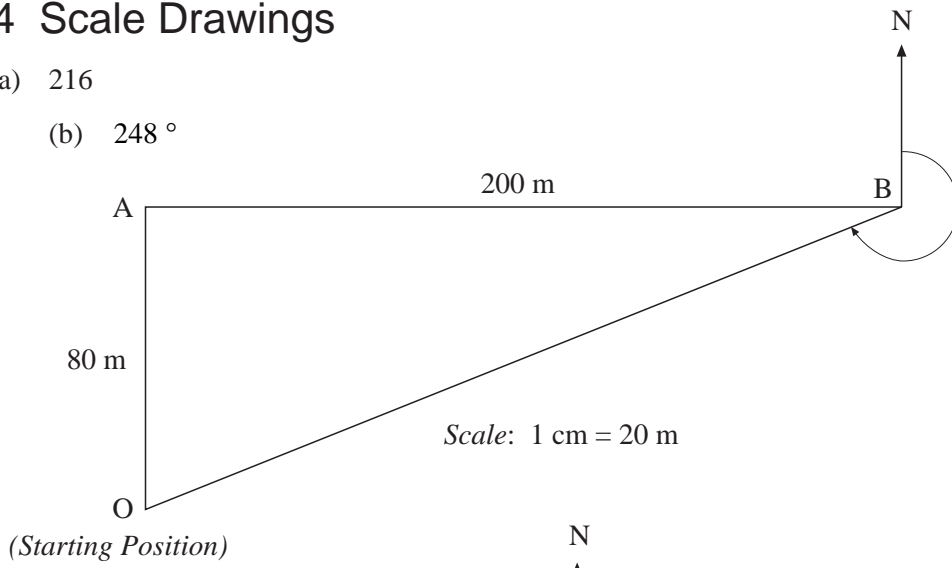

2. (a) 355 m

(b) 217°

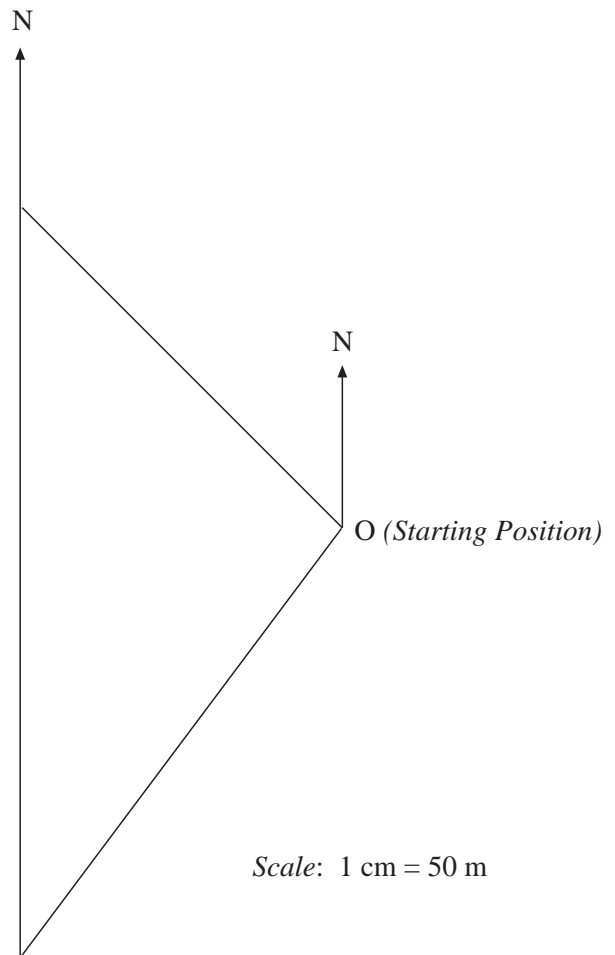

11.4

Answers

3. 420 km

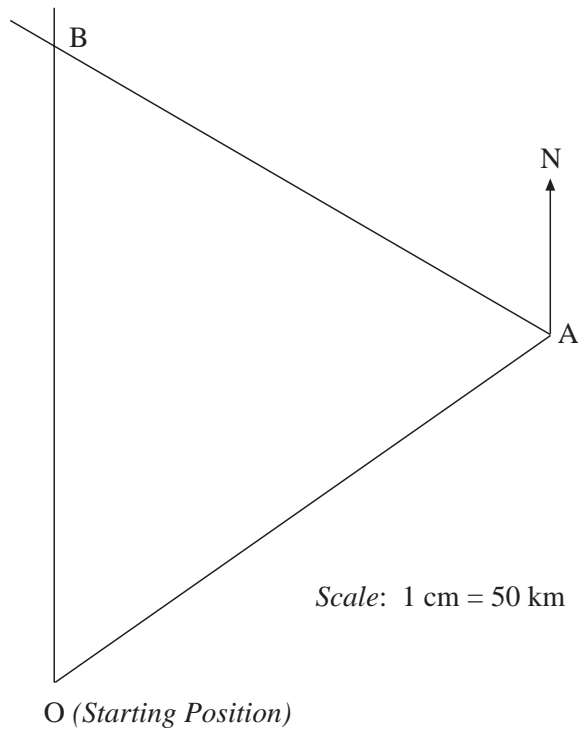

4. (a) 28.5 km

(b) 339°

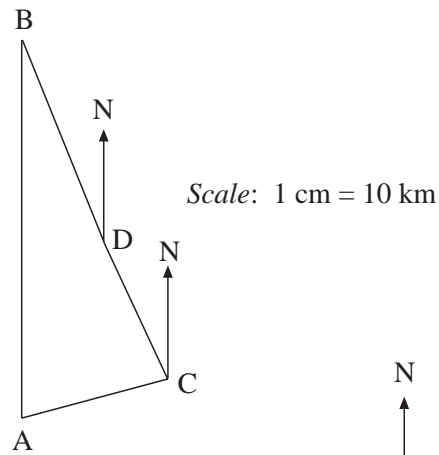

5. 52 m on bearing of 323°

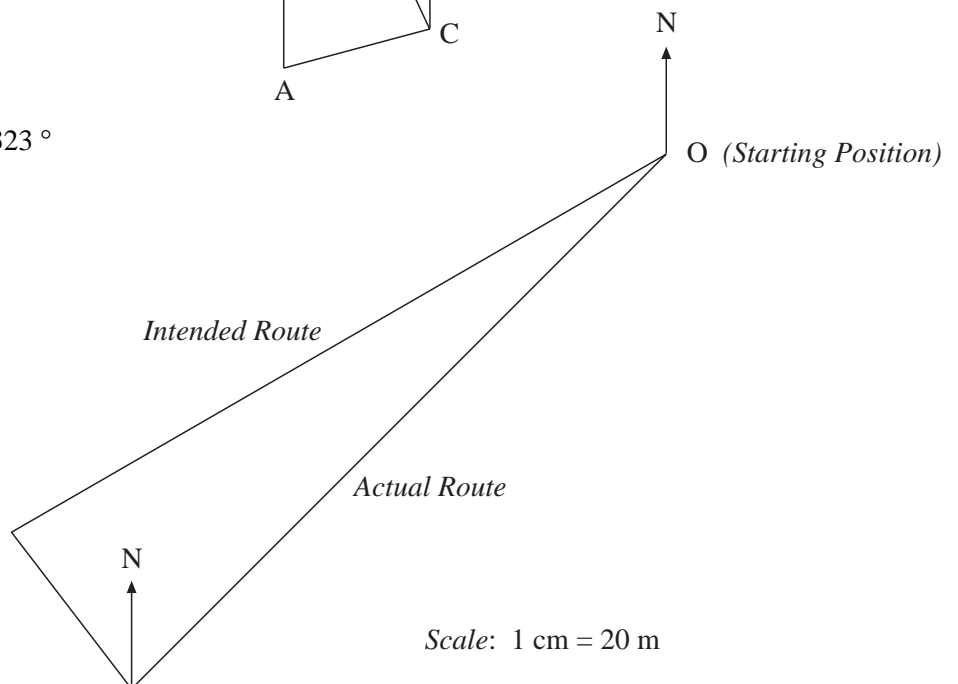

11.4

Answers

6. 11 km

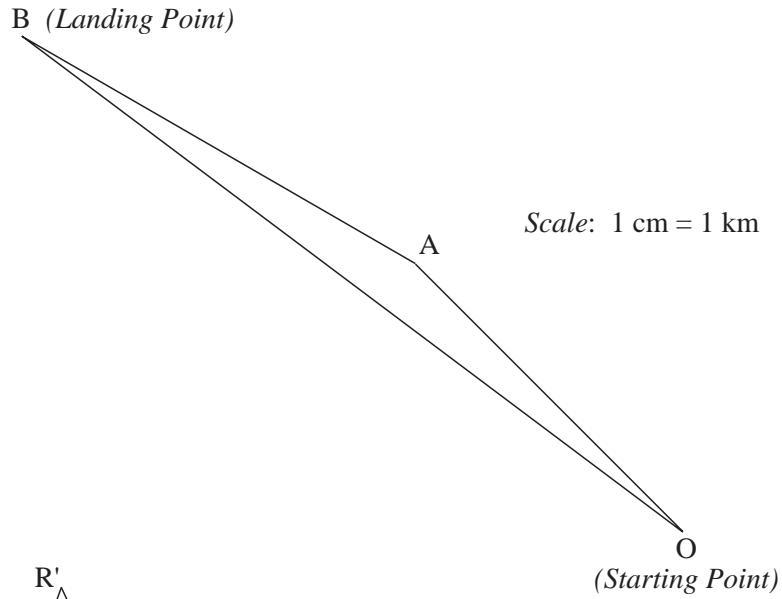

7. 5.6 km

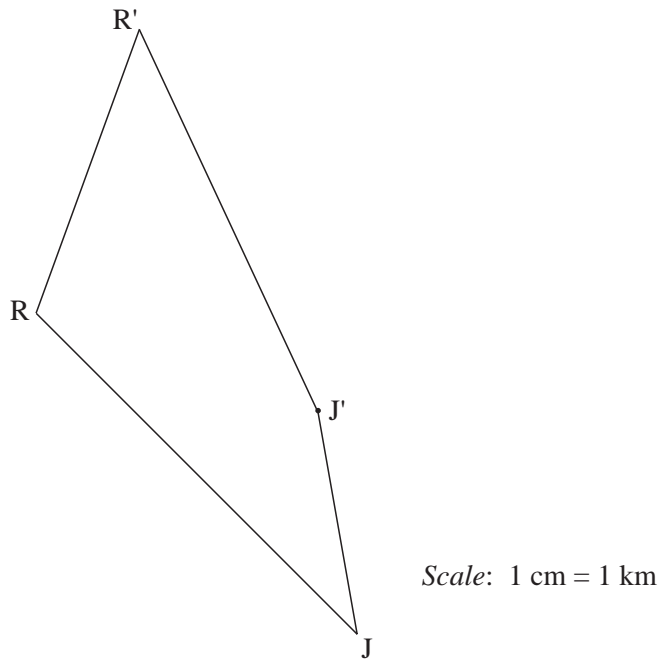

8. (a) 485 km

(b) 288°

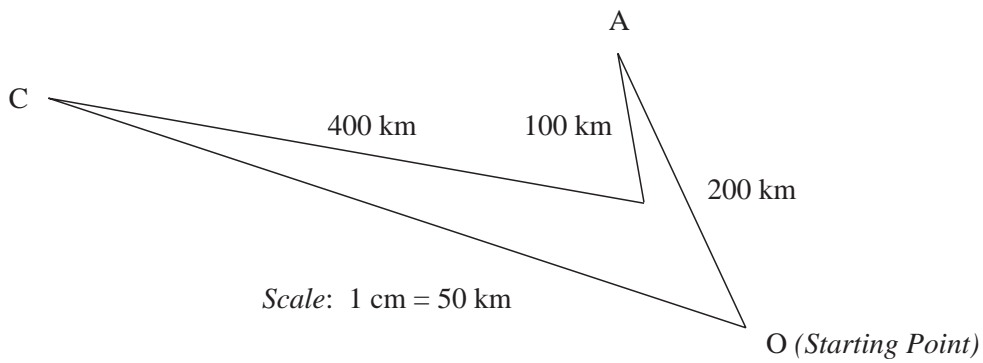

11.4

Answers

9. (a) 137° (b) 20.6 km

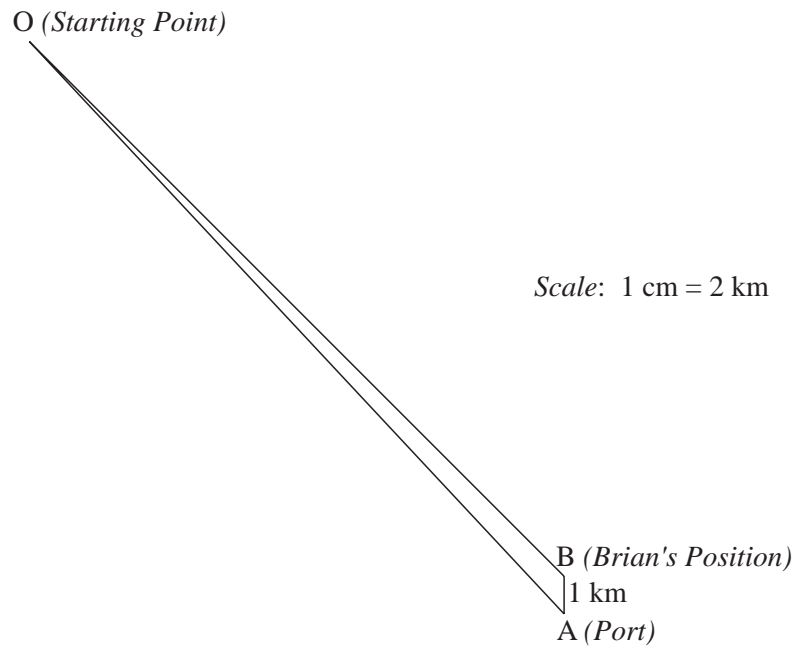

10. (a) 187° (b) 242°
or
 (a) 216° (b) 158°

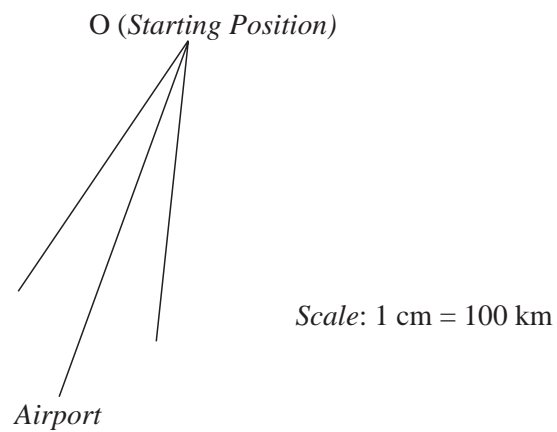

11.4

Answers

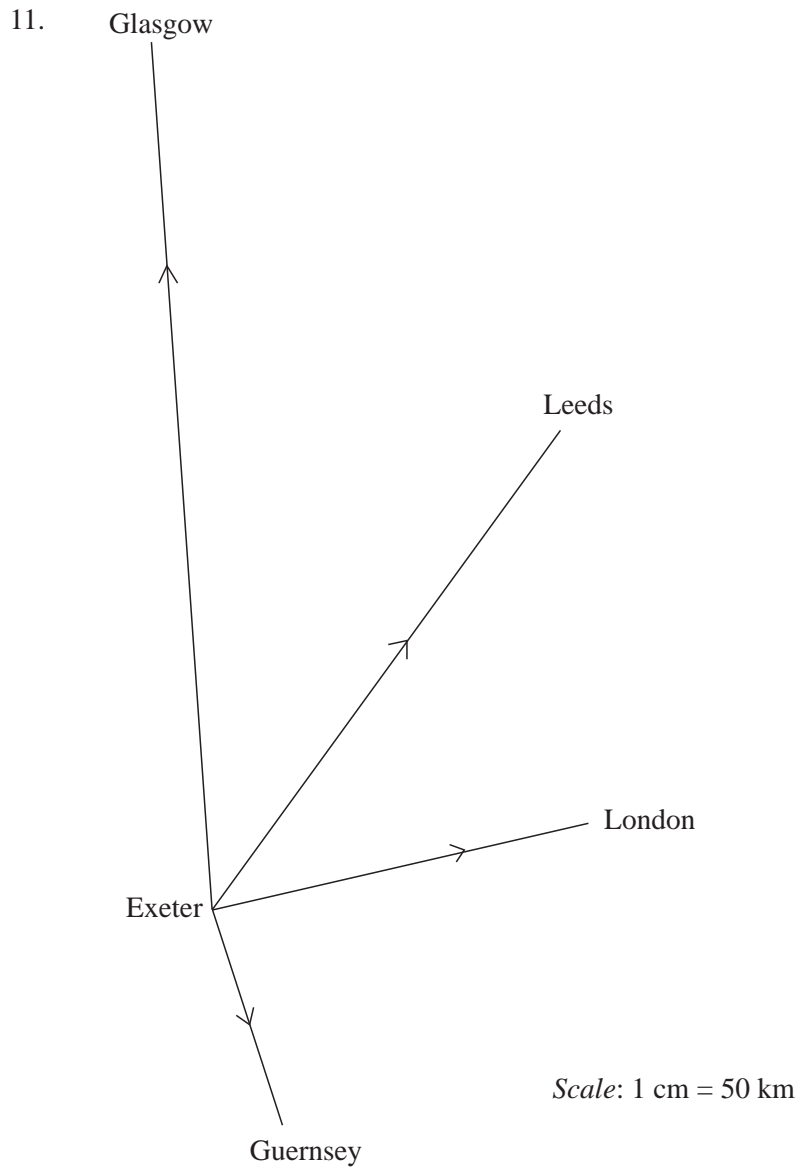

Practice Book *UNIT 12 Formulae*

Answers

12.1 Substitution 1

1. (a) 7 (b) 11 (c) 14 (d) 4 (e) 3
 (f) 7 (g) 16 (h) 12 (i) 6
2. (a) 14 (b) 12 (c) 10 (d) 35 (e) 18
 (f) 4 (g) 21 (h) 70 (i) 24
3. (a) 21 (b) 26 (c) 34 (d) 53
 (e) 36 (f) 94 (g) 11 (h) 6
 (i) 18 (j) 4 (j) 9 (l) 17
4. (a) 5 (b) 4 (c) 3 (d) 2 (e) 10
 (f) 5 (g) 2 (h) 1 (i) 15
5. (a) 50 (b) 20 (c) 200 (d) 40 (e) 2
 (f) 5 (g) 4 (h) 2 (i) 2 (j) 1000
 (k) 1000 (l) 1000 (m) 200 (n) 1 (o) 10
6. (a) 70 (b) 160 (c) 150 (d) 220 (e) 320 (f) 130
7. (a) 6 units (b) 20 units (c) 38 units (d) 26 units
8. (a) 18 units (b) 9 units (c) 47 units (d) 38 units
9. (a) £26 (b) £39 (c) £25 (d) £22 (e) £47 (f) £170
10. (a) 2 hours (b) 2 hours (c) 6 hours (d) 0.5 hours

12.2 Substitution 2

1. (a) 4 (b) 2 (c) -6 (d) -2 (e) 5 (f) -3 (g) -12
 (h) -50 (i) 48 (j) -2 (k) -2 (l) 5 (m) 9 (n) -50
 (o) 18 (p) 2 (q) 17 (r) -2 (s) 25 (t) -135 (u) 61
2. (a) 18 (b) 10 (c) 1 (d) 54 (e) 22 (f) 22
 (g) 126 (h) -3 (i) 84 (j) 9 (k) 27 (l) -4
3. (a) 20 (b) -8 (c) 20 (d) 6 (e) -1 (f) -4
 (g) 24 (h) -2 (i) 2
4. 3
5. $7\frac{1}{2}$ cm

12.2

Answers

6. 7.26 cm^2

7. 5 cm

8. (a) 212 (b) 68 (c) 14 (d) -4

9. (a) 45 (b) 2 (c) -24 (d) -90

10. (i) (a) $\frac{3}{10}$ (b) $\frac{7}{10}$ (c) $\frac{3}{20}$

(ii) Confirmed – the first formula is a rearrangement of the second.

11. A and D

12.3 Linear Equations 1

1. (a) 4 (b) 1 (c) 2 (d) 15 (e) 8 (f) 12
(g) 11 (h) 11 (i) -3 (j) 14 (k) -5 (l) -4

2. (a) 6 (b) 6 (c) 4 (d) 3 (e) 4
(f) 0 (g) 8 (h) 10 (i) 18 (j) 36
(k) 44 (l) 28 (m) $\frac{1}{2}$ (n) 12 (o) 0

3. (a) 2 (b) 14 (c) 11 (d) 10 (e) 11 (f) 7
(g) 11 (h) 16 (i) 7 (j) 810 (k) -2 (l) -32

4. (a) $6x = 18$ (b) $x = 3 \text{ cm}$ (c) 3 cm

5. (a) $x + 14 = 17$, $x = 3 \text{ cm}$ (b) $x = 3 \text{ cm}$

12.4 Linear Equations 2

1. (a) 5 (b) 3 (c) 2 (d) 6 (e) 3
(f) 2 (g) 6 (h) -1 (i) 4 (j) 3
(k) $\frac{1}{2}$ (l) $1\frac{1}{2}$ (m) 12 (n) 0 (o) -2

2. (a) 8 (b) 66 (c) 35 (d) -20 (e) 52 (f) 13
(g) 50 (h) -1 (i) 4 (j) 34 (k) 12 (l) 8

3. (a) 7 (b) $4\frac{1}{2}$ (c) 3 (d) $1\frac{2}{3}$
(e) 3 (f) 11 (g) 77 (h) $2\frac{1}{6}$

12.4

Answers

4. (a) $54 = \frac{9C}{5}$, $270 = 9C$, $30 = C$, $C = 30$

(b) 5 (c) -5

5. $50 = 2(x + 8)$

$25 = x + 8$ [Dividing both sides by 2]

$17 = x$ [Subtracting 8 from both sides]

$x = 17$ units

6. (a) $10 = 3 + 5a$

$7 = 5a$ [Subtracting 3 from both sides]

$\frac{7}{5} = a$ [Dividing both sides by 5]

$a = \frac{7}{5}$

(b) $2 = 5 + 3a$

$-3 = 3a$ [Subtracting 5 from both sides]

$-1 = a$ [Dividing both sides by 3]

$a = -1$

7. 2 cm

8. 7 cm

9. 4.5 cm

10. (a) $x = 4$ cm (b) 12 cm and 8 cm

12.5 Non-Linear Equations

1. (a) 3.9 (1 d.p.) (b) 4.8 (1 d.p.) (c) 2.9 (1 d.p.) (d) 7.7 (1 d.p.)

2. (a) $x = 1$ $x^3 - x^2 = 0 < 2$

$x = 2$ $8 - 4 = 4 > 2$, so solution lies between 1 and 2.

(b) 1.70

3. (a) $x = 2$ $x^2 + 2x + 3 = 11 < 15$

$x = 3$ $x^2 + 2x + 3 = 36 > 15$, so solution lies between 2 and 3.

(b) 2.61

4. $2.33 < x < 2.335$ so $x = 2.33$ (2 d.p.)

12.6

Answers

12.6 Changing the Subject of a Formula

1. (a) $x = y + 2$ (b) $x = y - 7$ (c) $x = \frac{y}{4}$ (d) $x = 3y$

(e) $x = \frac{y-1}{2}$ (f) $x = \frac{y+3}{4}$ (g) $x = \frac{y}{2} - 3$ or $x = \frac{y-6}{2}$

(h) $x = \frac{y}{3} + 4$ or $x = \frac{y+12}{3}$ (i) $x = \frac{y}{m}$ (j) $x = y - a$

(k) $x = \frac{y+c}{k}$ (l) $x = \frac{y-b}{a}$

2. (a) $a = \frac{y-b}{x}$ (b) $b = y - ax$

3. $x = \frac{2y+7}{3}$

4. $C = \frac{5(F-32)}{9}$

5. (a) $a = p - b - c$ (b) $c = p - a - b$

6. (a) $p = 2w + 2l$ (b) $w = \frac{p-2l}{2}$ (c) $A = wl$ (d) $l = \frac{A}{w}$

7. (a) $p = 2l + 2x + b$ (b) $x = \frac{p-2l-b}{2}$ (c) $l = \frac{p-2x-b}{2}$

(d) $b = p - 2l - 2x$

8. (a) $h = \frac{2A}{a+b}$ (b) $a = \frac{2A}{h} - b$

9. (a) $p = 10x$ (b) $x = \frac{p}{10}$

10. (a) $A = 2y^2 - 4x^2$ (b) $x = \sqrt{\frac{2y^2 - A}{4}}$ (c) $y = \sqrt{\frac{A + 4x^2}{2}}$

Practice Book *UNIT 13 Money and Time***Answers**

13.1 Money

1. (a) £2.41 (b) £3.89
2. £12.95
3. £57.49
4. (a) £10.54 (b) £9.46
5. (a) £21.57 (b) £25.72
6. (a) £9.00 (b) £8.70
7. £3.41
8. (a) £6.66 (b) 2 pence
9. (a) £50 (b) £7.50
10. (a) £10.62 (b) £3.54

13.2 Time

1. (a) 0645 (b) 1845 (c) 1420 (d) 2340
(e) 1030 (f) 2215
2. (a) 4:42 p.m. (b) 8:32 a.m. (c) 10:42 a.m. (d) 10:36 p.m.
(e) 11:18 p.m. (f) 3:32 p.m.
3. (a) No more than 60 mins in the hour!
(b) No more than 24 hours in a day.
4. 2 hrs 47 min
5. 2 hrs 58 min
6. 11 hrs 51 min
7. (a) 11:00 a.m. (b) 6:30 p.m. (c) 3:15 a.m.
8. (a) 2:45 p.m. (b) 11:52 a.m.
9. (a) 6:00 p.m. (b) 3:30 a.m. (c) 8:30 a.m.
10. (a) 1200 on Tuesday (b) 2112 on Saturday (c) 0312 on Tuesday

Answers

13.3 Time and Money

1. (a) Janice £26.60
 Martin £32.50
 Gail £31.50
2. A : £152 B : £144 Job A pays the most.
3. £16.80
4. (a) £60 (b) £63.60
5. (a) 38 hrs (b) £247
6. (a) 31 hrs (b) £133.30 (c) £146.63
7. (a) 920 hrs (b) £6.00 (c) £5630.40
8. (a) £4.50 (b) £4.68 (c) 4%
9. (a) £4.20 (b) £18.20 (c) £4.33 (to nearest pence)
10. £161.88

Practice Book *UNIT 14 Straight Line Graphs*

Answers

14.1 Coordinates

1. A (4, 8); B (5, -3); C (3, -7); D (-5, -2); E (-2, 5); F (7, 4);
 G (3, -2); H (-3, -6); I (-6, -5); J (-5, 2); K (-5, 8)

2. (a), (b)

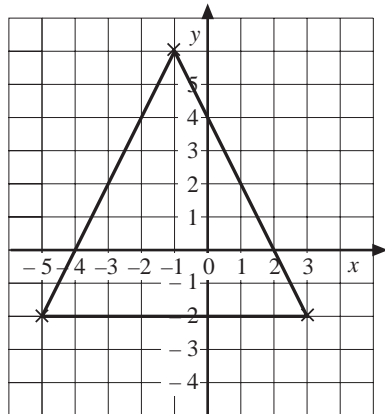

- (c) isosceles

3. (a), (b)

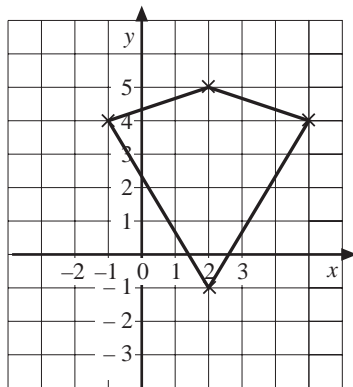

- (c) kite

4. (-1, -3)

5. (-1, -5)

6. (a)

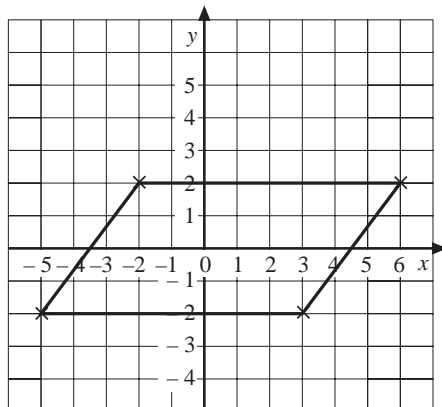

- (b) parallelogram

14.1

Answers

7. (a)

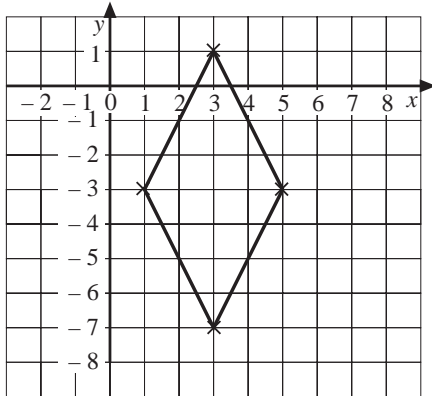

(b) rhombus

8. (a)

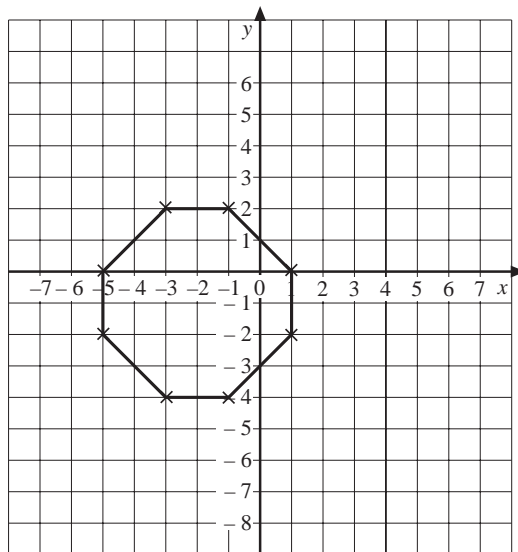

(b) regular octagon

9. (a)

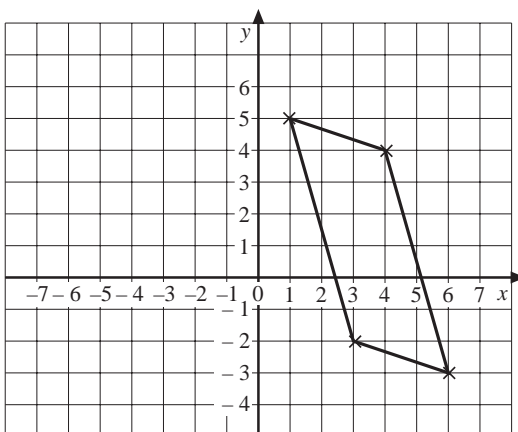

(b) (3, -2)

14.1

Answers

10. (a)

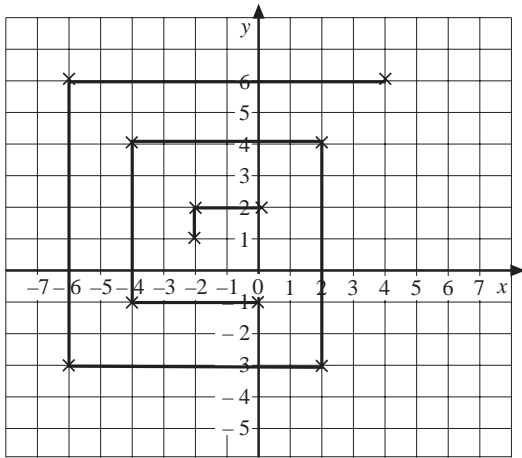

(b) $(-6, -3), (-6, 6), (4, 6)$

14.2 Plotting Points on Straight Lines

1. (a), (b)

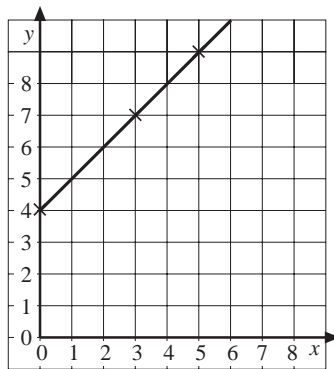

(c) $(2, 6), (4, 8), (6, 10)$

2. (a), (b)

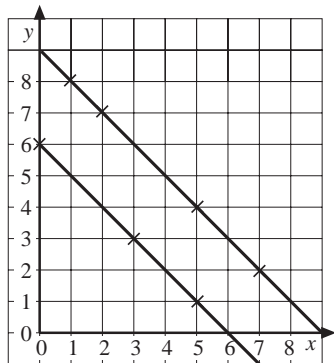

(c) These two lines are parallel.

3. (a), (b)

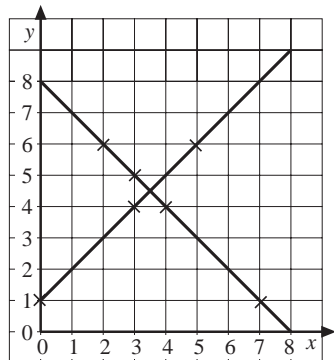

(c) These two lines are perpendicular.

14.2

Answers

4. (a)

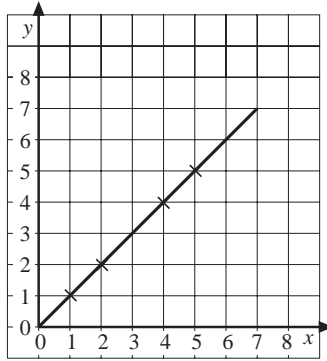

(b) For example, (0, 0), (3, 3)

(c) The y -coordinate is the same as (equals) the x -coordinate, i.e. $y = x$.

5. (a)

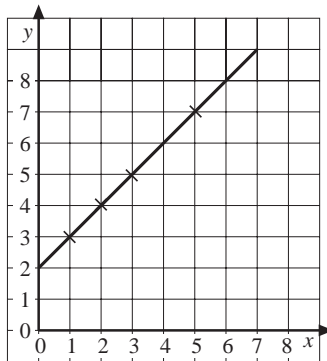

(b) For example, (0, 2), (4, 6), (6, 8)

(c) The y -coordinate is always 2 more than the x -coordinate, i.e. $y = x + 2$.

6. (a)

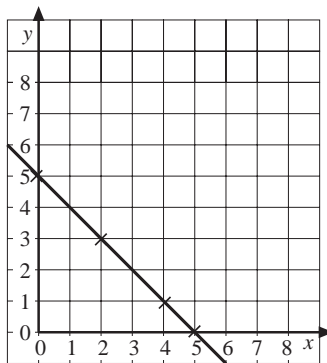

(b) For example, (1, 4), (3, 2)

(c) 5

7. (a), (b)

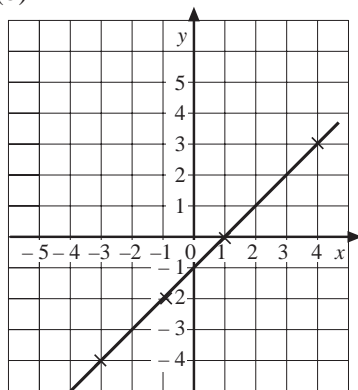

(c) The y -coordinate is always one less than the x -coordinate, i.e. $y = x - 1$.

14.2

Answers

8. (a)

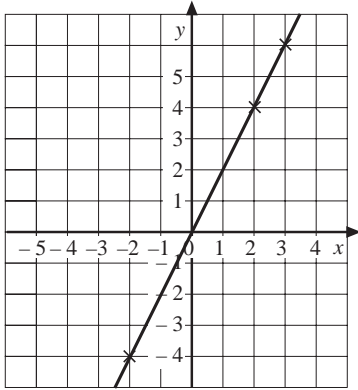

(b) The y -coordinate is always twice the x -coordinate,
i.e. $y = 2x$.

9. (a)

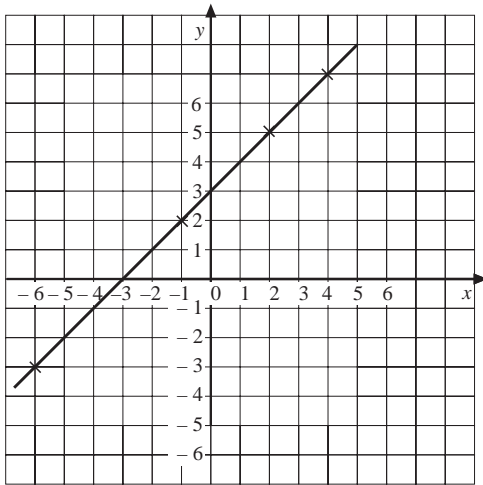

(b) $(-7, -4), (-4, -1), (3, 6), (1, 4), (100, 103)$

(c) The y -coordinate is always 3 more than the x -coordinate, i.e. $y = x + 3$.

(d) No. 27 is only 2 more than 25.

10. (a)

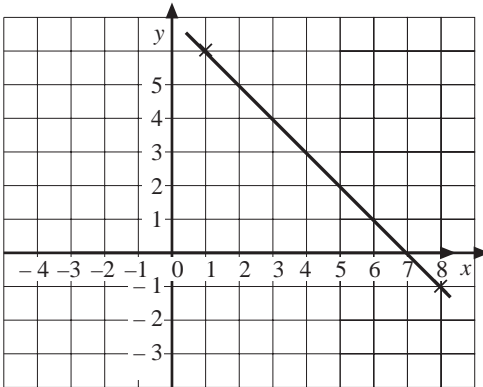

$x + y = 7$

(b)

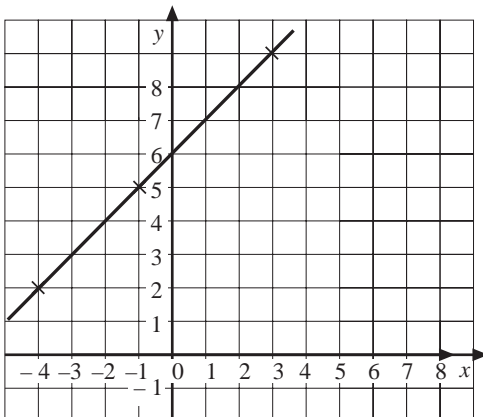

$y = x + 6$

14.2

Answers

10. (c)

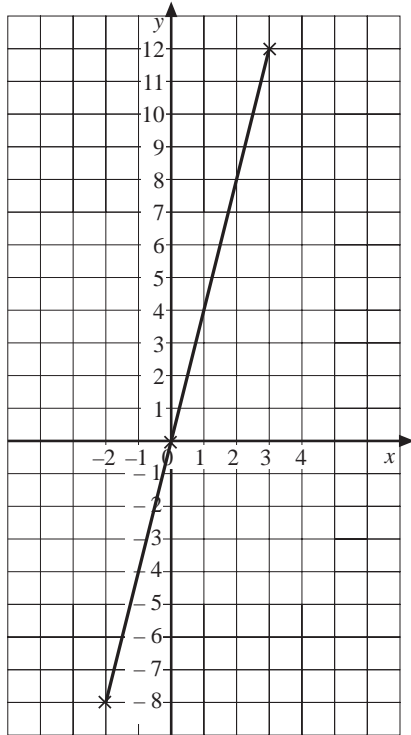

$y = 4x$

(d)

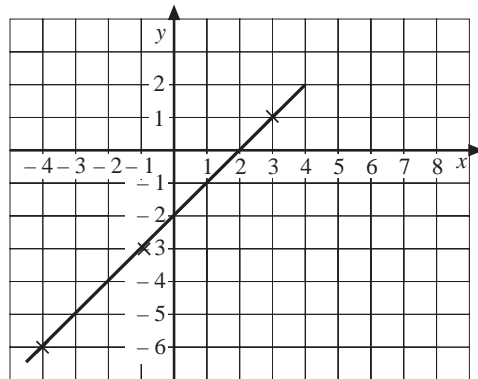

$y = x - 2$

14.3 Plotting Graphs Given Their Equations

- 1. Positive: A, C, F Negative: B, D, E
- 2. (a) 4 (b) 1 (c) 5 (d) 2
- (e) $1\frac{1}{2}$ (f) 1 (g) $2\frac{1}{2}$ (h) 0
- 3. (a) -1 (b) -4 (c) -3 (d) -2

4. (a)

| | | | | | | | |
|-----|----|----|----|----|----|---|---|
| x | -3 | -2 | -1 | 0 | 1 | 2 | 3 |
| y | -5 | -4 | -3 | -2 | -1 | 0 | 1 |

14.3

Answers

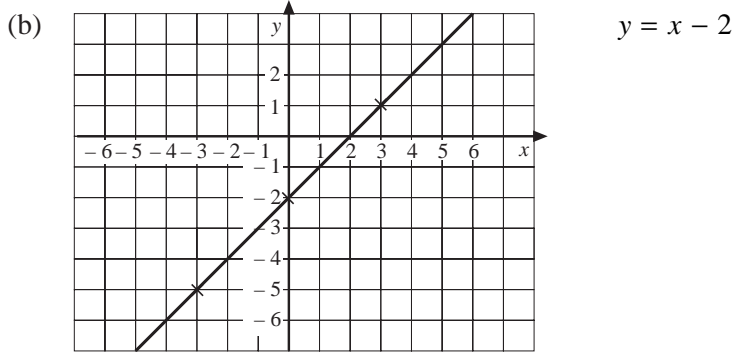

5. (a)

| | | | | | | | |
|-----|----|----|----|---|---|---|---|
| x | -3 | -2 | -1 | 0 | 1 | 2 | 3 |
| y | -3 | -1 | 1 | 3 | 5 | 7 | 9 |

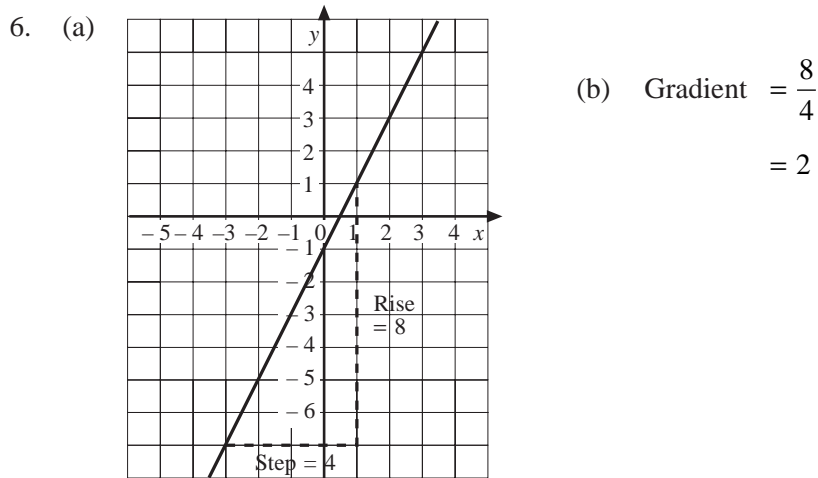
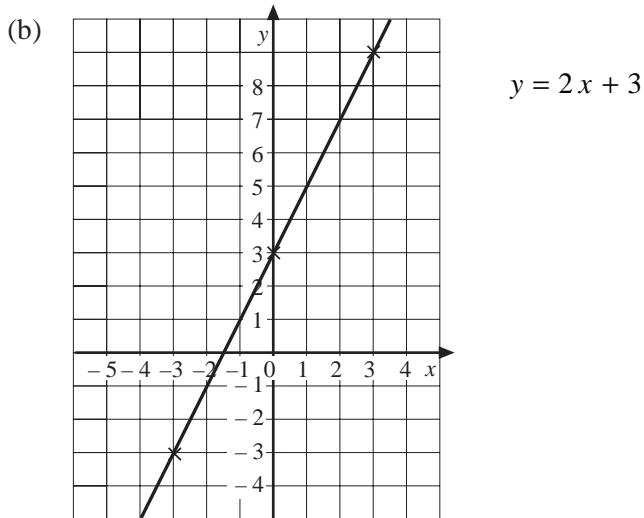

14.3

Answers

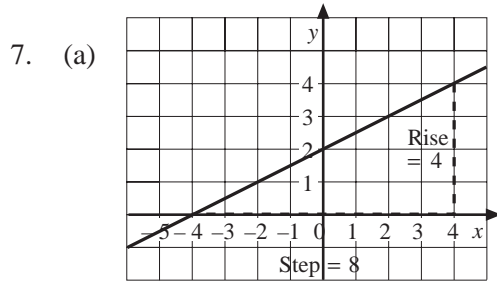

(b) Gradient = $\frac{4}{8}$
 $= \frac{1}{2}$

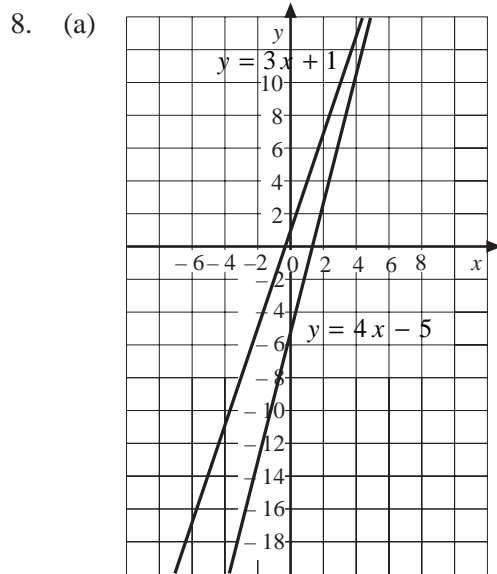

(b) $y = 3x + 1$ Gradient = 3
 $y = 4x - 5$ Gradient = 4

9. (a) 2 (b) 3 (c) 10 (d) 5

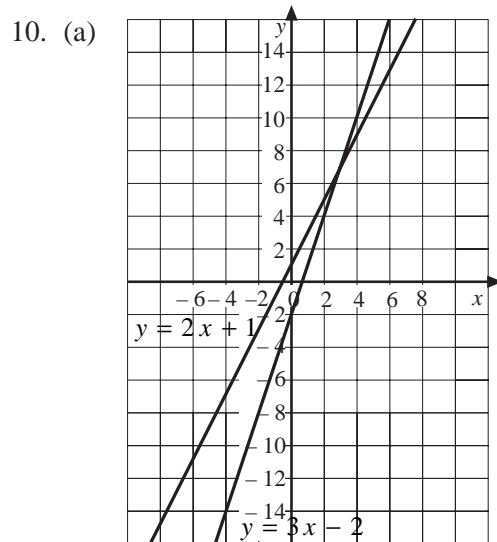

(b) (3, 7)

14.3

Answers

11.

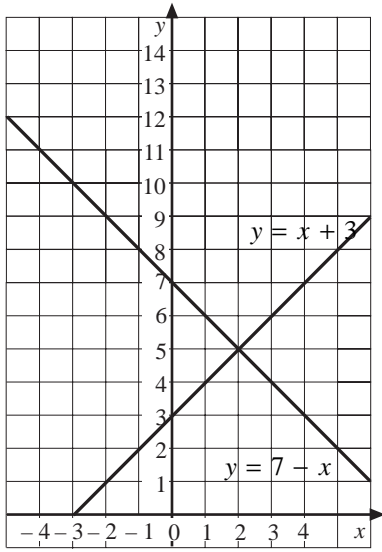

Coordinates of intersection = (2, 5)

12. (a)

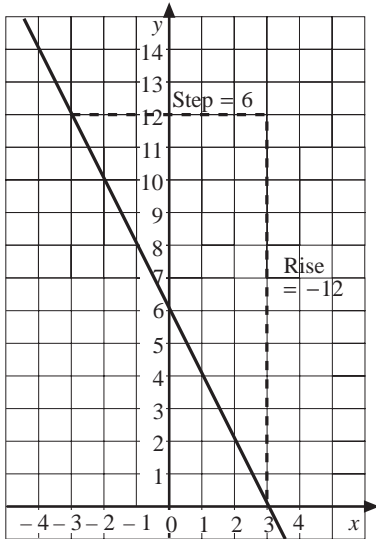

(b) Gradient = $\frac{-12}{6}$
 $= -2$

13. (a) Both lines have gradient = -2.

(b) For example, $y = 7 - 2x$.

(c) See diagram

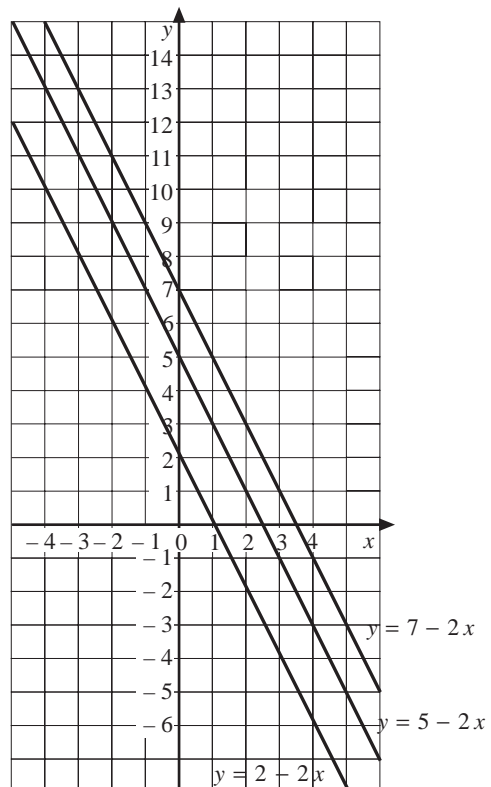

Answers

14.4 The Equation of a Straight Line

1. (a)

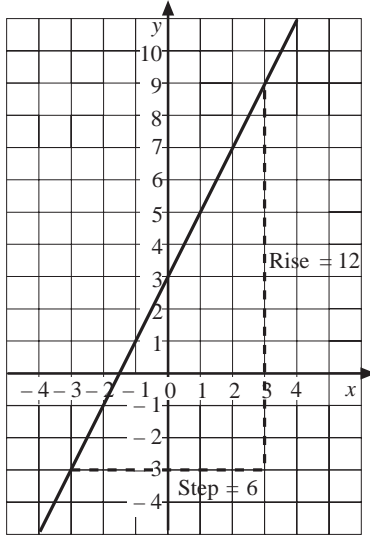

(b) Gradient = $\frac{12}{6}$
 $= 2$

(c) Intercept = 3

2. (a)

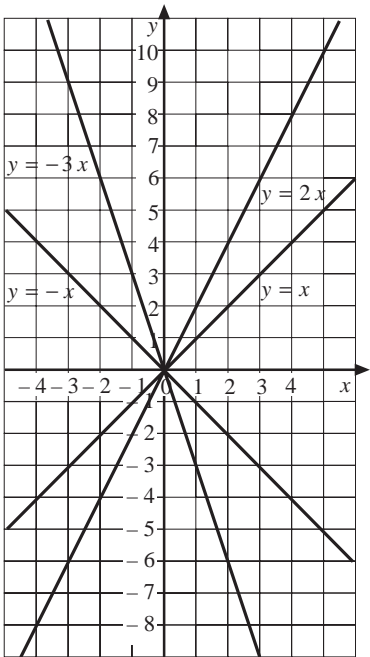

(b) Gradients = 1, -1, 2, -3

(c) $y = 0$

3. (a)

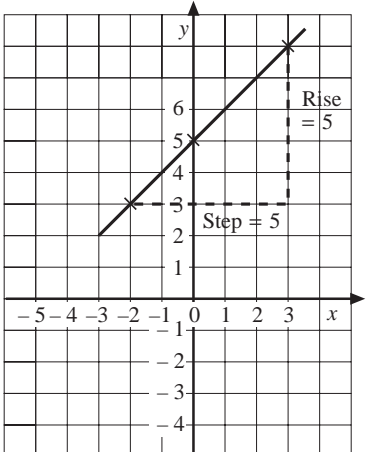

(b) Gradient = $\frac{\text{Rise}}{\text{Step}}$
 $= 1$

(c) $y = 5$

(d) $y = x + 5$

14.4

Answers

| 4. | m | c | $y = mx + c$ |
|-----|-----|-----|-------------------------------|
| (a) | 1 | -3 | $y = x - 3$ |
| (b) | 2 | 2 | $y = 2x + 2$ |
| (c) | -1 | 4 | $y = -x + 4$ or $y = 4 - x$ |
| (d) | -3 | 2 | $y = -3x + 2$ or $y = 2 - 3x$ |

| 5. | Equation | Gradient | Intercept |
|----|---------------|----------|-----------|
| | $y = 2x + 7$ | 2 | 7 |
| | $y = 8x - 2$ | 8 | -2 |
| | $y = 8 - 3x$ | -3 | 8 |
| | $y = 7x - 5$ | 7 | -5 |
| | $y = -3x + 2$ | -3 | 2 |
| | $y = -5x - 2$ | -5 | -2 |

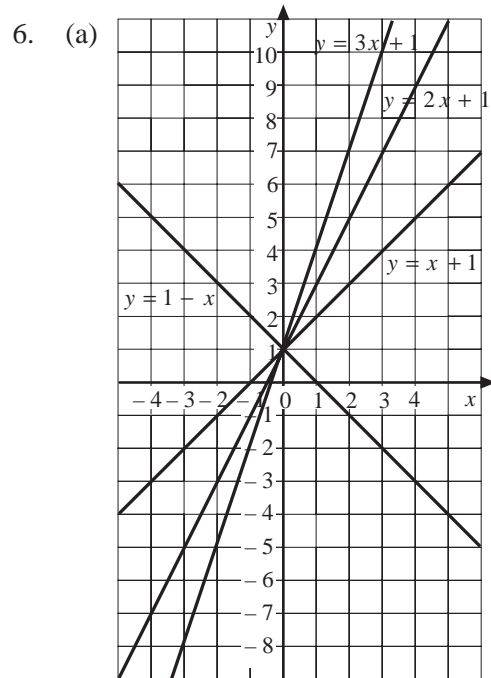

(b) All lines pass through $y = 1$ since $c = 1$ in each equation (same intercept).

7. (a) Gradient = $\frac{15}{5} = 3$ (b) $y = 0$ (c) $y = 3x$

14.4

Answers

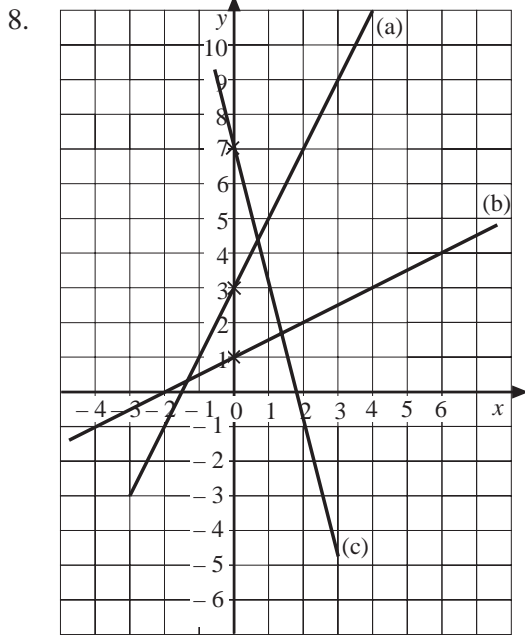

14.5 The Equation of a Line Given Two Points

1. (a) Gradient = $\frac{6}{3} = 2$ (b) $y = 2x - 1$
2. $y = 7x$
3. Since $c = 0$ (intercept $y = 0$)
4. (a) $y = 3x + 1$ (b) $y = 3x + 11$ (c) $y = -2x + 100$ or $y = 100 - 2x$
- (d) $y = -3x + 6$ or $y = 6 - 3x$ (e) $y = 2x + 8$ (f) $y = -\frac{7}{4}x - \frac{25}{2}$
5. $y = -4x + 27$

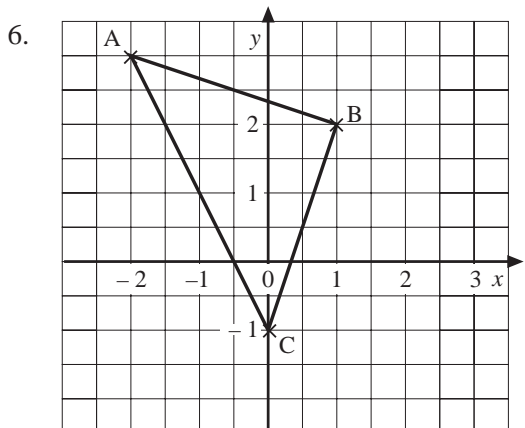

| Line | Gradient | Intercept | Equation |
|------|----------------|---------------|-----------------------------------|
| A B | $-\frac{1}{3}$ | $\frac{7}{3}$ | $y = -\frac{1}{3}x + \frac{7}{3}$ |
| B C | 3 | -1 | $y = 3x - 1$ |
| A C | -2 | -1 | $y = -2x - 1$ |

14.5

Answers

7.

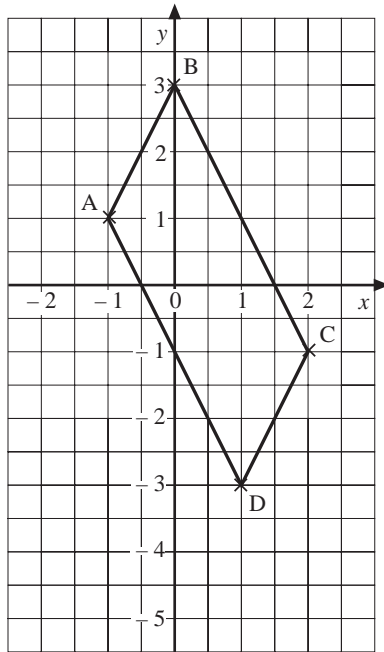

| Line | Gradient | Intercept | Equation |
|------|----------|-----------|---------------|
| A B | 2 | 3 | $y = 2x + 3$ |
| B C | -2 | 3 | $y = -2x + 3$ |
| C D | 2 | -5 | $y = 2x - 5$ |
| A D | -2 | -1 | $y = -2x - 1$ |

Practice Book *UNIT 15 Polygons*Answers

15.1 Angle Facts

1. (a) 127° (b) 163° (c) 141° (d) 50°
2. (a) 36° (b) 61° (c) 47° (d) 49°
3. (a) 131° (b) 67° (c) 34° (d) 50°
4. $a = b = 70^\circ$
5. $a = 37^\circ$, $b = 70^\circ$
6. $b = 47^\circ$, $a = c = 133^\circ$ (a and c are equal - vertically opposite)
7. $a = 106^\circ$, $b = 74^\circ$, $c = 53^\circ$
8. $a = 89^\circ$, $b = 91^\circ$, $c = 66^\circ$
9. $a = 80^\circ$, $b = 9^\circ$, $c = 86^\circ$
10. $a = 57^\circ$, $b = 86^\circ$, $c = 123^\circ$, $d = 57^\circ$, $e = 110^\circ$

15.2 Angle Properties of Polygons

1. (a) 30° (b) 5° (c) 18° (d) 6°
2. (a) Exterior = 45° , Interior = 135°
(b) Exterior = 36° , Interior = 144°
3. (a) 150° (b) 1800°
4. (a) 162° (b) 3240°
5. 72°
6. 30 sides
7. (a) (i) 12 (ii) 72 (iii) 20 (iv) 60
(b) Interior angle = 123° , Exterior angle = 57°

No. of sides = $\frac{360}{57}$ which is not an exact integer, so a regular polygon not possible.

15.2

Answers

8. (a)

| <i>Number of Sides</i> | <i>Exterior Angles</i> | <i>Interior Angles</i> | <i>Sum of Interior Angles</i> |
|------------------------|------------------------|------------------------|-------------------------------|
| 4 | 90 ° | 90 ° | 360 ° |
| 5 | 72 ° | 108 ° | 540 ° |
| 6 | 60 ° | 120 ° | 720 ° |
| 7 | 51 $\frac{3}{7}$ ° | 128 $\frac{4}{7}$ ° | 900 ° |
| 8 | 45 ° | 135 ° | 1080 ° |
| 9 | 40 ° | 140 ° | 1260 ° |
| 10 | 36 ° | 144 ° | 1440 ° |
| 12 | 30 ° | 150 ° | 1800 ° |

(b) If n = no. of sides of regular polygon, $\text{sum} = (n - 2) \times 180^\circ$.

(c) Sum of interior angles.

9. (a) 90 (b) $(90 - 2) \times 180 = 15840^\circ$

10. (a) $\frac{360^\circ}{\text{no. of sides}}$ (b) Interior angle = $180^\circ - \text{exterior angle}$
 $= 180^\circ - \frac{360^\circ}{n}$

(c) $\text{sum} = 180^\circ(n - 2)$

15.3 Symmetry

1. (a)

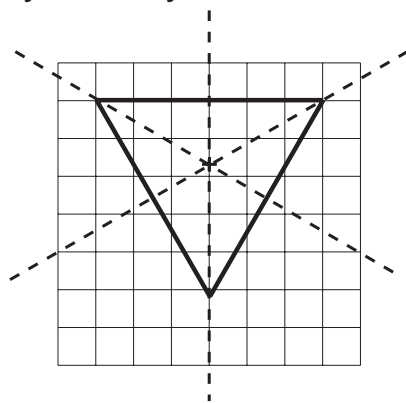

Order of rotational symmetry 3

(b)

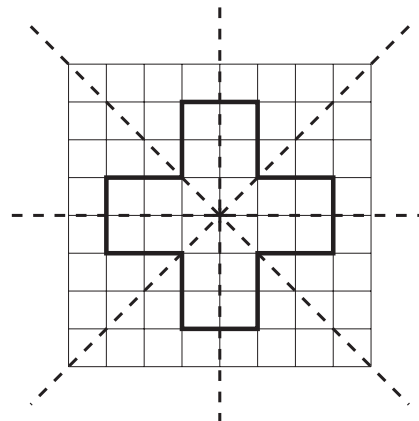

Order of rotational symmetry 4

15.3

Answers

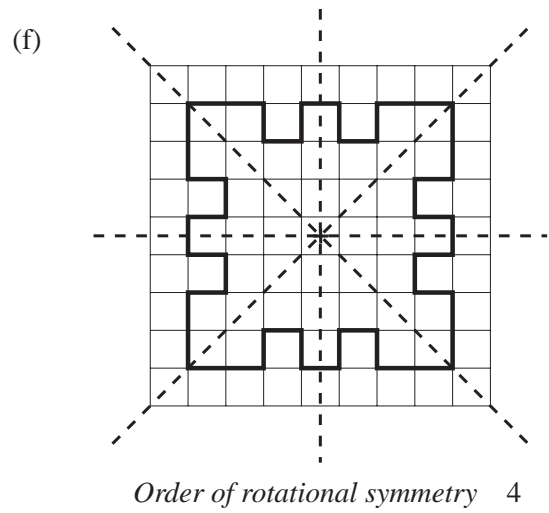
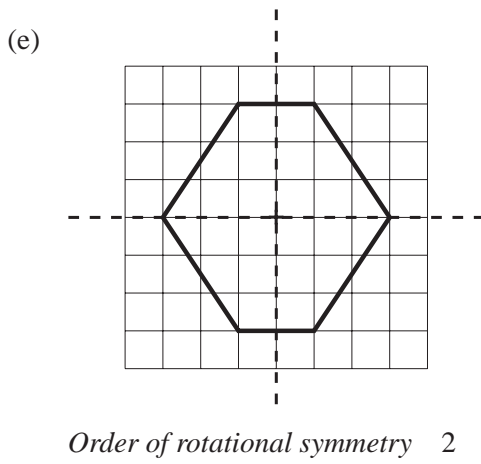
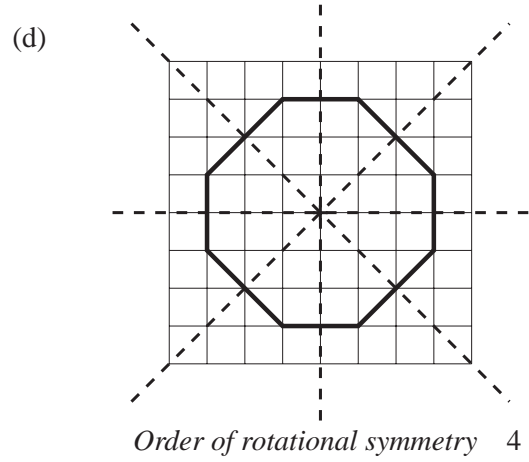
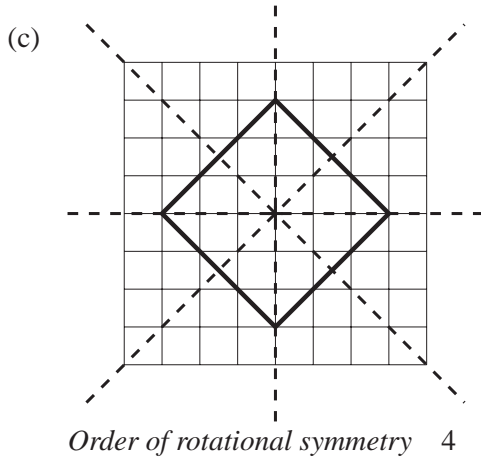

2.

| | <i>Order of Rotational Symmetry</i> | <i>No. of Lines of Symmetry</i> |
|-----|-------------------------------------|---------------------------------|
| (a) | 4 | 4 |
| (b) | 1 | 1 |
| (c) | 2 | 2 |
| (d) | 2 | 2 |
| (e) | 2 | 2 |
| (f) | 1 | 1 |

3.

| | <i>Order of Rotational Symmetry</i> | <i>No. of Lines of Symmetry</i> |
|-----|-------------------------------------|---------------------------------|
| (a) | 6 | 0 |
| (b) | 3 | 3 |

15.3

Answers

| | | |
|-------------|-------------------------------------|---------------------------------|
| 4. | <i>Order of Rotational Symmetry</i> | <i>No. of Lines of Symmetry</i> |
| Equilateral | 3 | 3 |
| Isosceles | 1 | 1 |
| Scalene | 1 | 0 |

5. (a) 4 (b) 4

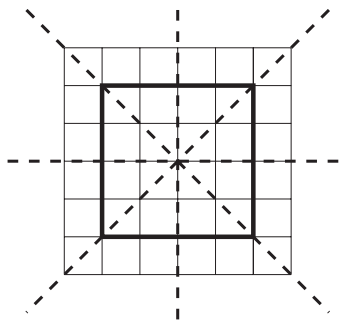

6. (a)

| <i>Shape</i> | <i>Order of Rotational Symmetry</i> | <i>Number of Lines of Symmetry</i> |
|-------------------------------------|-------------------------------------|------------------------------------|
| <i>Equilateral triangle</i> | 3 | 3 |
| <i>Square</i> | 4 | 4 |
| <i>Regular pentagon</i> | 5 | 5 |
| <i>Regular hexagon</i> | 6 | 6 |
| <i>Regular heptagon (7 sides)</i> | 7 | 7 |
| <i>Regular octagon</i> | 8 | 8 |
| <i>Regular nonagon (9 sides)</i> | 9 | 9 |
| <i>Regular decagon (10 sides)</i> | 10 | 10 |
| <i>Regular dodecagon (12 sides)</i> | 12 | 12 |

(b) The number of lines of symmetry = order of rotational symmetry for a regular polygon.

7. Pupil's own design.

15.3

Answers

8. Pupil's own design, e.g.

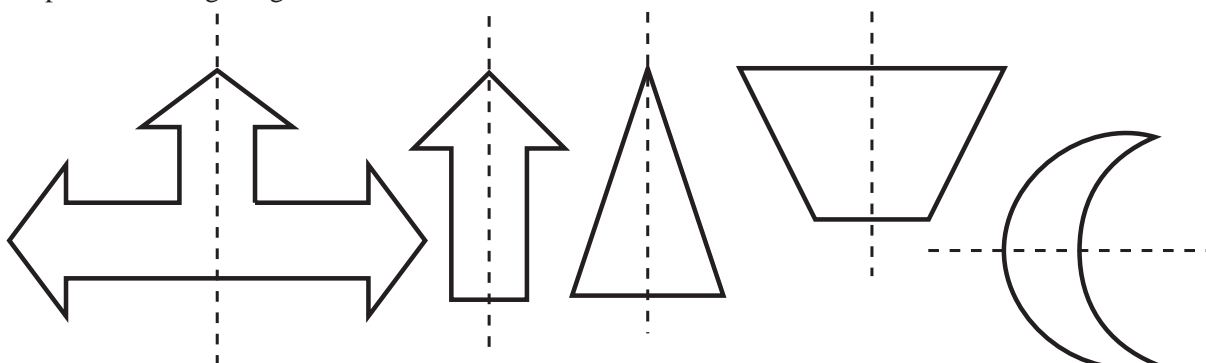

9. E.g:

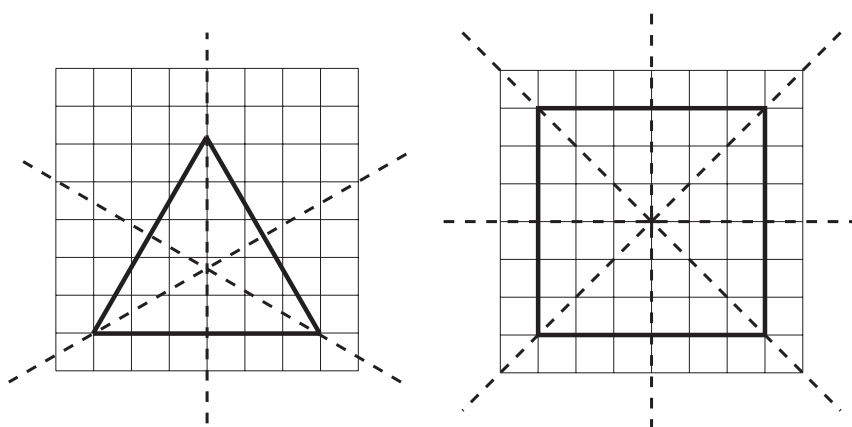

Odd number of sides – lines of symmetry through vertex and middle of opposite side.

Even number of sides – lines of symmetry through middle of opposite sides, or diagonal vertices.

10.

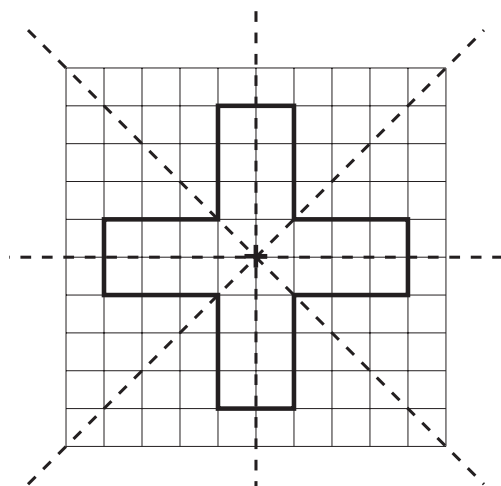

Order of rotational symmetry = 4

Answers

15.4. Quadrilaterals

1. Rectangle, Square
2. (a) Rectangle (but not square), Rhombus (but not square)

(b)

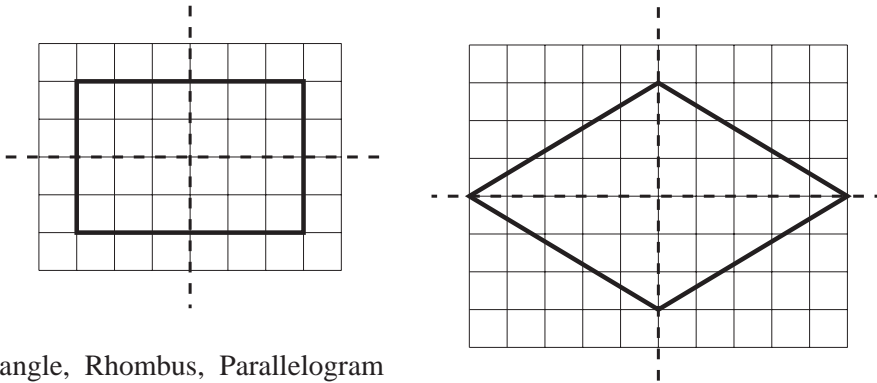

3. Rectangle, Rhombus, Parallelogram

4. (a) Kite and Isosceles Trapezium

(b)

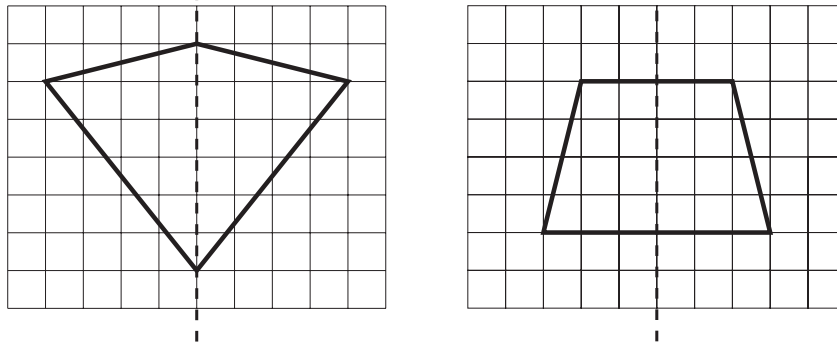

5. (a) Trapezium (b) Kite (c) Rectangle
(d) Rhombus (e) Trapezium (f) Parallelogram

6. Parallelogram (unless it is a rectangle), Rhombus (unless it is a square), Kite, Trapezium (unless it is isosceles)

7. (a) The quadrilateral must be a rhombus.
(b) The quadrilateral could be a square if it contains 4 right angles.

8. (a) Rectangle, Square, Rhombus

(b)

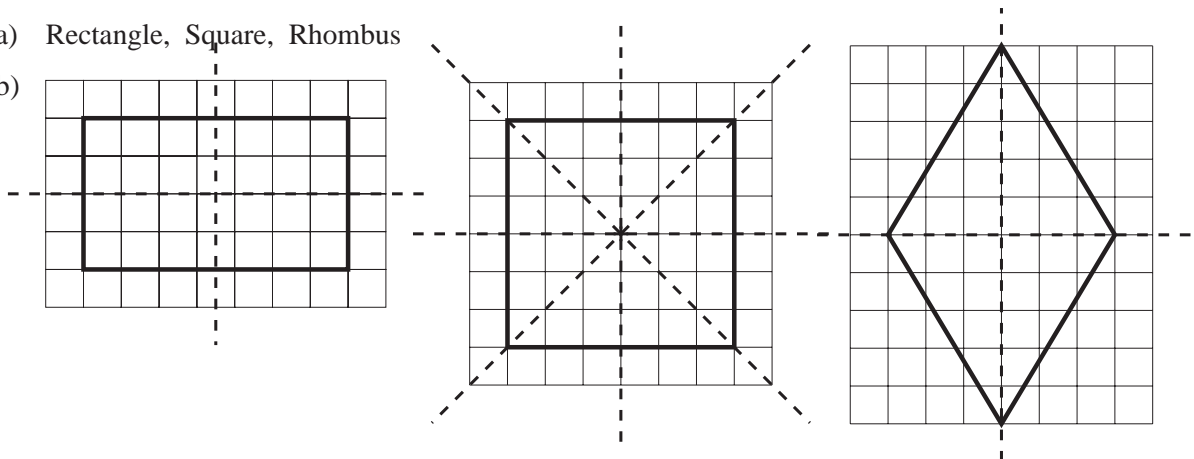

15.4

Answers

| (c) Name | Order of Rotational Symmetry |
|---------------|------------------------------|
| Rectangle | 2 |
| Square | 4 |
| Parallelogram | 2 |
| Rhombus | 2 |

9. A Square B Rectangle C Rhombus D Parallelogram
 E Trapezium F Kite G General quadrilateral

10. A variety of acceptable solutions, e.g.

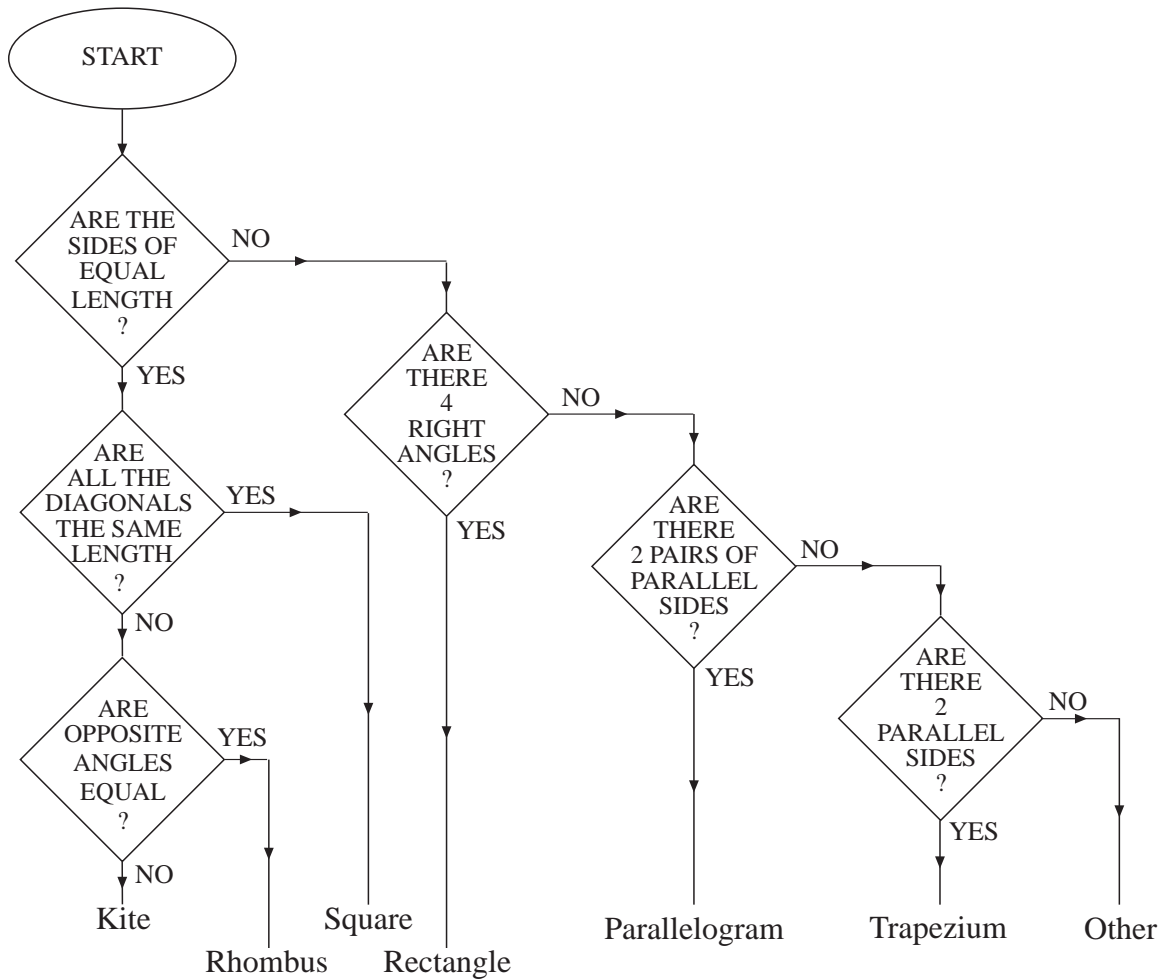

Practice Book *UNIT 16 Circles and Cylinders*

Answers

16.1 Introduction to Circles

1. (a) Radius (b) Chord (c) Chord (d) Radius
 (e) Chord (f) Diameter (g) Chord
2. (a) C, F (b) A, E (c) D
3. (a), (b), (c), (d)

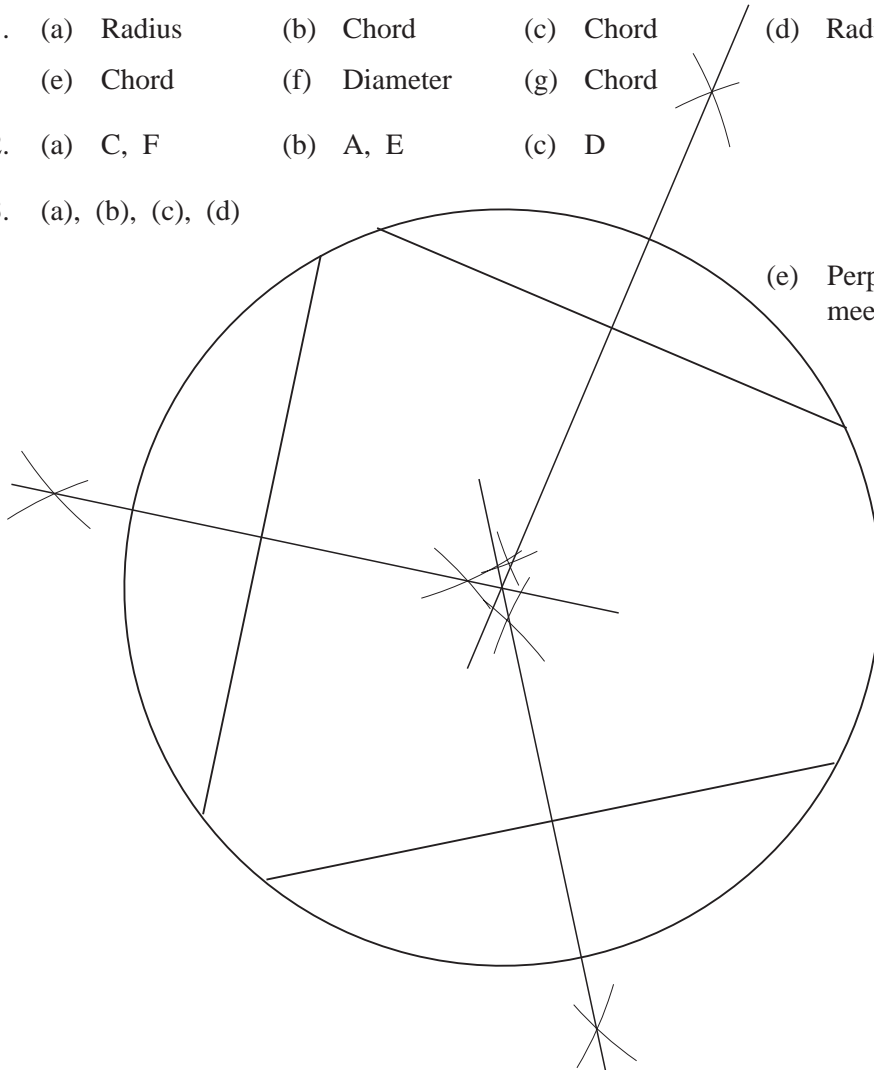

(e) Perpendicular bisectors of chords meet at the centre of the circle.

4. (a), (b)

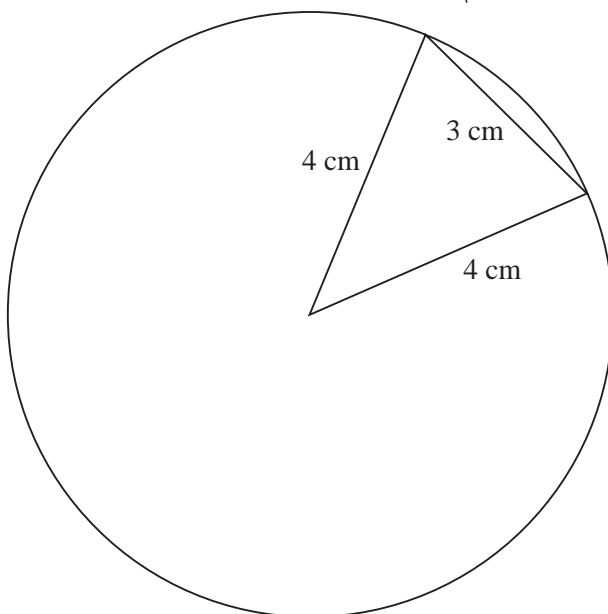

(c) Perimeter of triangle = 11 cm

16.1

Answers

5. (a)

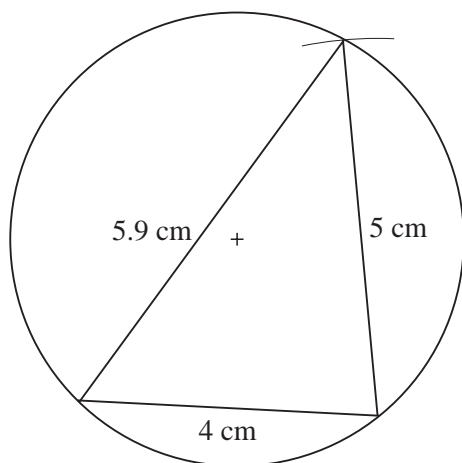

(b) Perimeter = $4 + 5 + 5.9$
 $= 14.9 \text{ cm}$

6. (a)

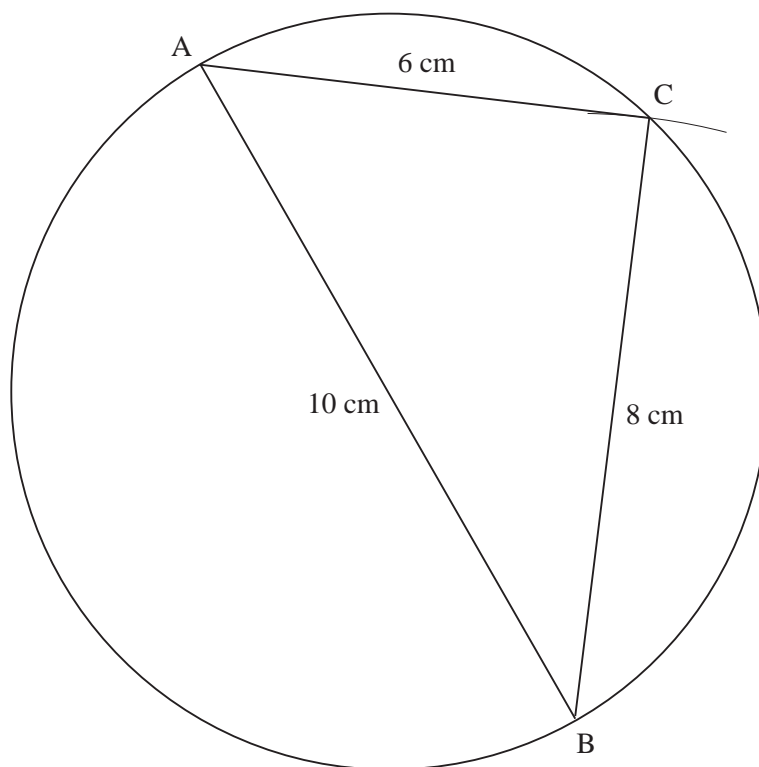

- (b) 6 cm
- (c) 90°
- (d) $A = \frac{1}{2} \times 8 \times 6$
 $= 24 \text{ cm}^2$

7. (a)

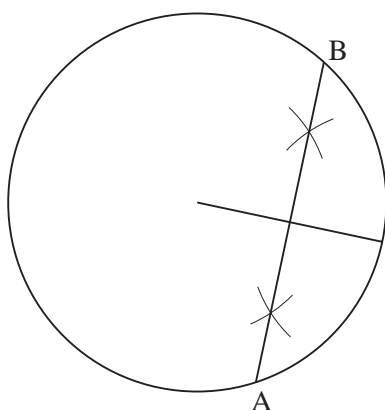

(b) Chord AB $\approx 4.3 \text{ cm}$

16.1

Answers

8. (a)

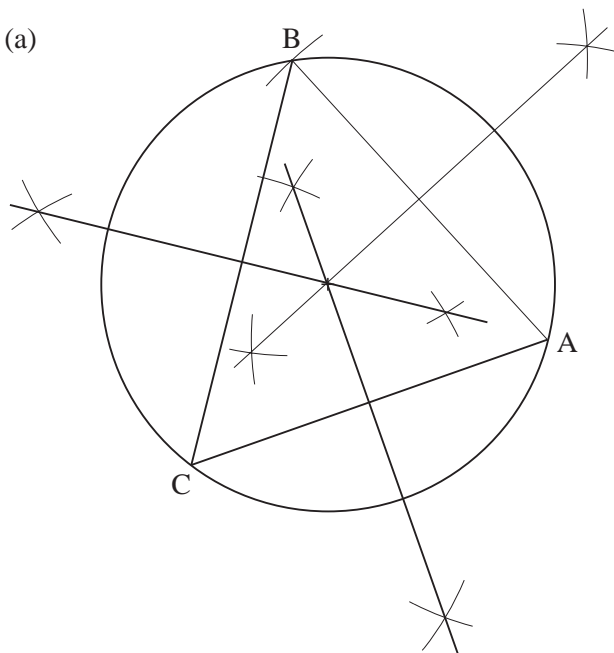

- (b) $AB = AC = 5 \text{ cm}$
Third side $BC = 5.5 \text{ cm}$
- (c) Perpendicular bisectors
- (d) 1.7 cm, 1.7 cm, 1.2 cm

9. (a), (b), (c)

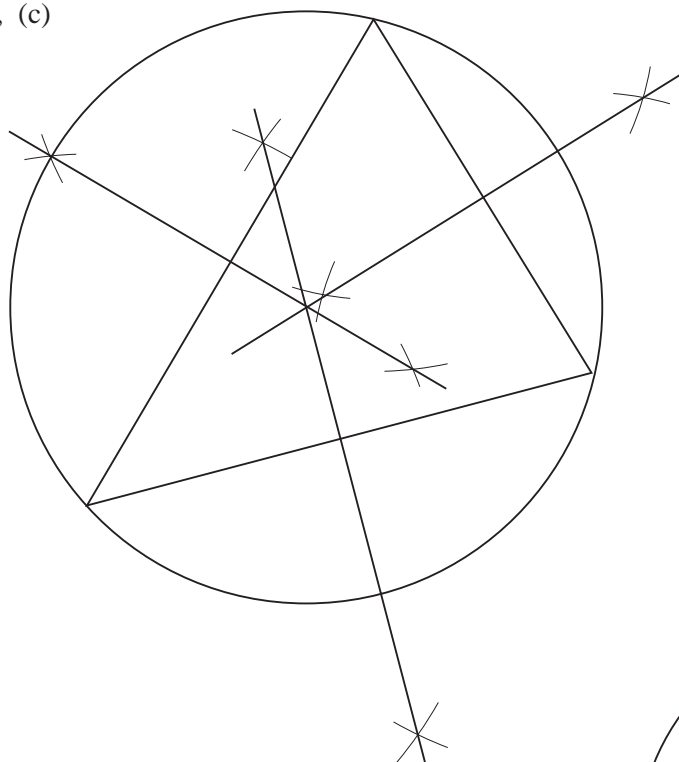

10. Distance from centre of chord to centre of circle = 2.2 cm.

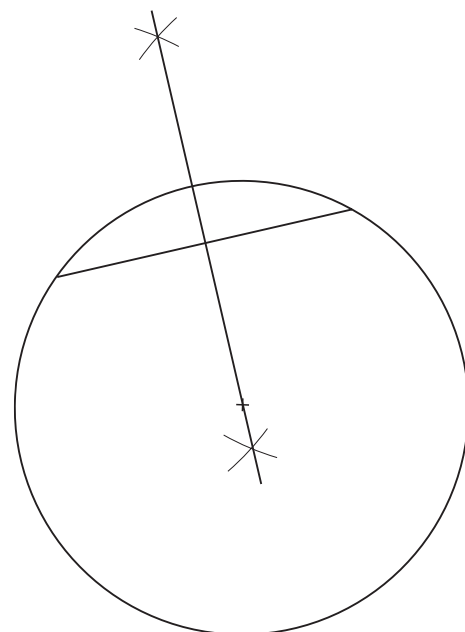

Answers

16.2 Estimating the Circumference of a Circle

1. (a)

| <i>Radius</i> | <i>Diameter</i> | <i>Circumference (measured)</i> |
|---------------|-----------------|---------------------------------|
| 1 cm | 2 cm | 6.3 cm |
| 2 cm | 4 cm | 12.6 cm |
| 3 cm | 6 cm | 18.9 cm |
| 4 cm | 8 cm | 25.1 cm |
| 5 cm | 10 cm | 31.4 cm |
| 6 cm | 12 cm | 37.7 cm |

3. (a)

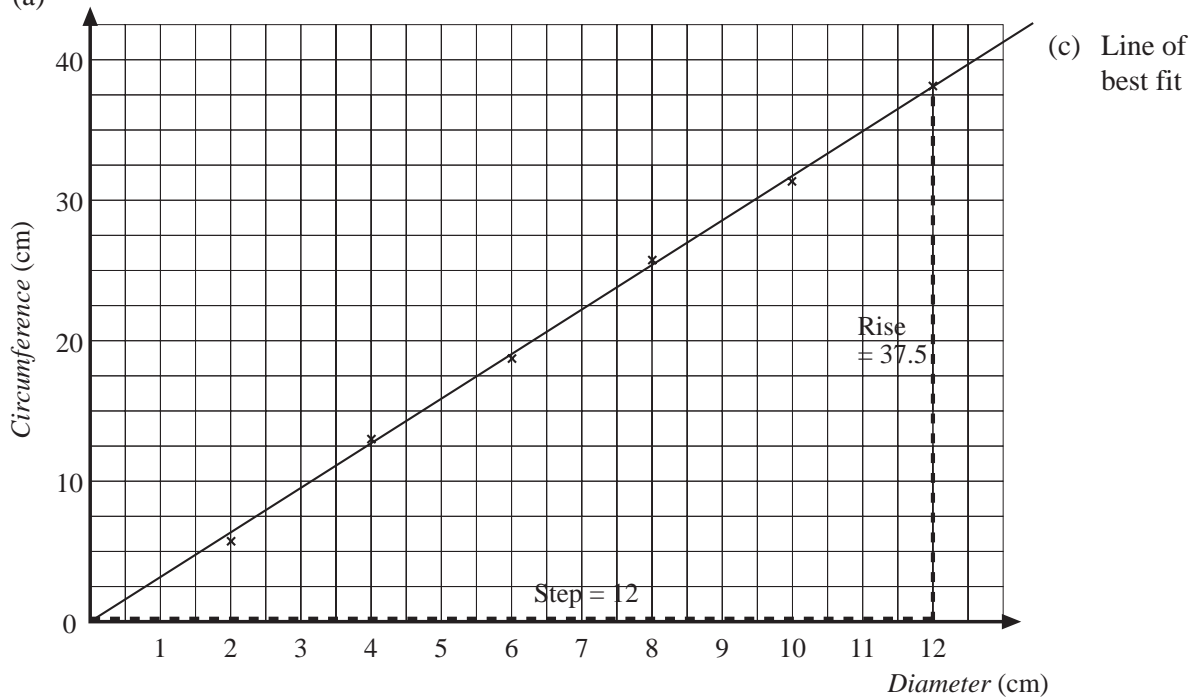

(b) Line should pass through (0, 0) since for diameter = 0, circumference = 0.

(d) $C = kd$ where $k = \text{gradient} = \frac{\text{rise}}{\text{step}}$

$$= \frac{37.5}{12}$$

Answers

16.3 Estimating the Area of a Circle

1. (a)

| <i>Radius</i> | <i>Area (approx.)</i> |
|---------------|-----------------------|
| 1 cm | 3 cm ² |
| 2 cm | 13 cm ² |
| 3 cm | 28 cm ² |
| 4 cm | 50 cm ² |
| 5 cm | 79 cm ² |
| 6 cm | 113 cm ² |
| 7 cm | 154 cm ² |

2. $A = 0 \text{ cm}^2$

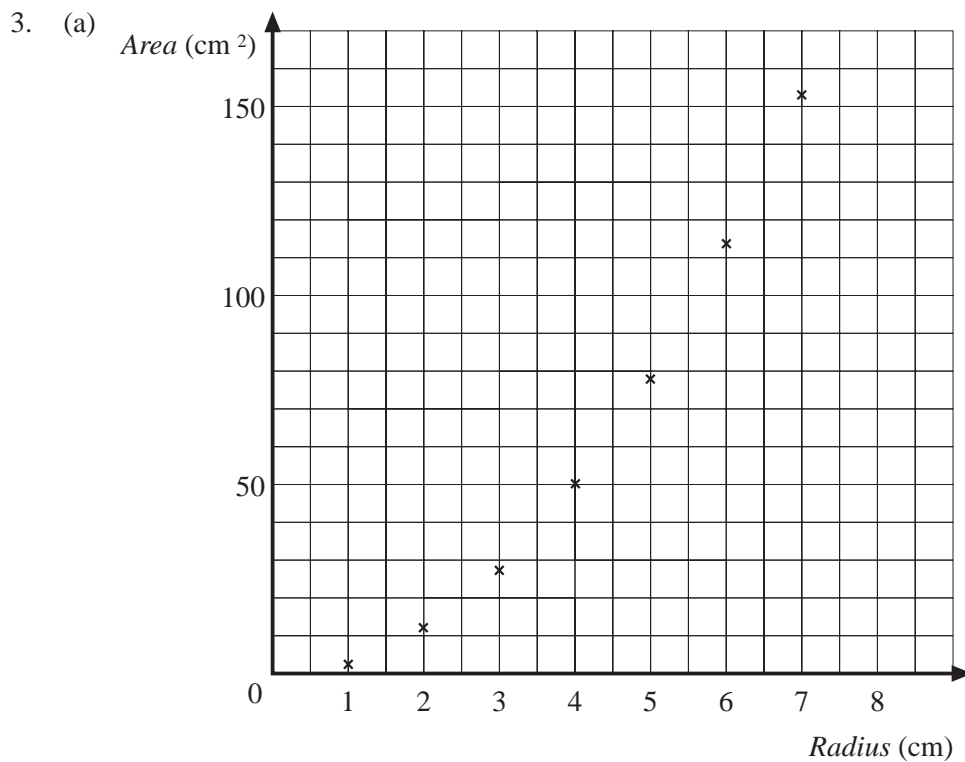

4. (a)

| | | | | | | | | |
|--|---|---|----|----|----|----|-----|-----|
| <i>Radius (cm)</i> | 0 | 1 | 2 | 3 | 4 | 5 | 6 | 7 |
| <i>Radius</i> ² (cm) ² | 0 | 1 | 4 | 9 | 16 | 25 | 36 | 49 |
| <i>Area (approx.) (cm)</i> ² | 0 | 3 | 13 | 28 | 50 | 79 | 113 | 154 |

16.3

Answers

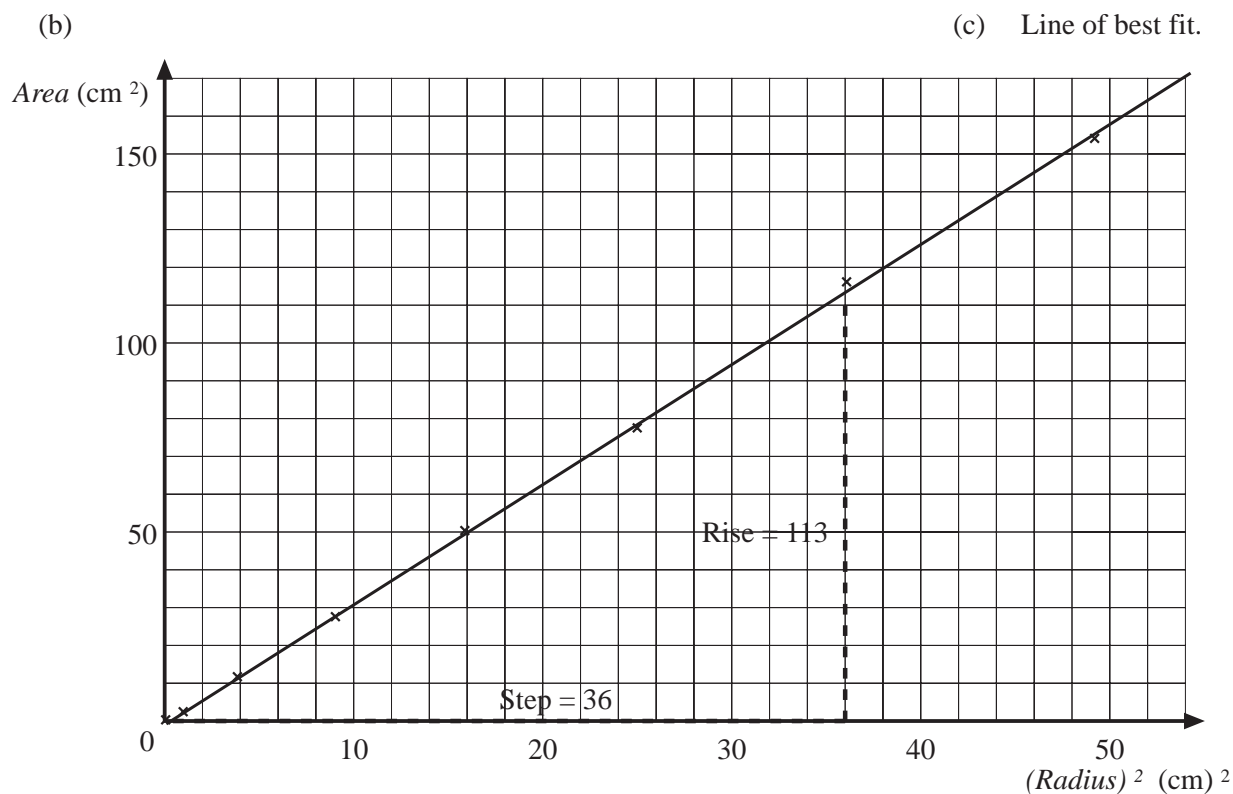

(d) $A = k r^2$ where $k = \text{gradient} = \frac{\text{rise}}{\text{step}}$

$$= \frac{113}{36}$$

$$\approx 3.14 \text{ (2 d.p.)}$$

16.4 Formulae for Circumference and Area

- (a) $d = 22 \text{ cm}$ (b) $C = 69.1 \text{ cm}$ (3 s.f.) (c) $A = 380 \text{ cm}^2$ (3 s.f.)
- $C = 50.3 \text{ cm}$ (3 s.f.) $A = 201 \text{ cm}^2$ (3 s.f.)
- $C = 59.7 \text{ cm}$ (3 s.f.) $A = 284 \text{ cm}^2$ (3 s.f.)

16.4

Answers

4.

| <i>Radius</i> | <i>Diameter</i> | <i>Circumference</i> | <i>Area</i> |
|---------------|-----------------|----------------------|-----------------------|
| 12 cm | 24 cm | 75.4 cm | 452.4 cm ² |
| 1 cm | 2 cm | 6.3 cm | 3.1 cm ² |
| 3 mm | 6 mm | 18.8 mm | 28.3 mm ² |
| 4.5 m | 9 m | 28.3 m | 63.6 m ² |
| 11.5 km | 23 km | 72.3 km | 415.5 km ² |

(Note: answers to Circumference and Area all correct to 1 d.p.)

5. $C = 37.7 \text{ cm}$ (3 s.f.) $A = 113 \text{ cm}^2$ (3 s.f.)

6. (a) 150 cm^2 (b) 50.3 cm^2 (3 s.f.) (c) 99.7 cm^2 (3 s.f.)

7. $A = 39.3 \text{ cm}^2$ (3 s.f.) $P = 25.7 \text{ cm}$ (3 s.f.)

8. (a) $r = 4.62 \text{ cm}$ (3 s.f.) (b) $A = 66.9 \text{ cm}^2$ (3 s.f.)

9. $r = 3.91 \text{ cm}$ (3 s.f.) $C = 24.6 \text{ cm}$ (3 s.f.)

10.

| <i>Radius</i> | <i>Diameter</i> | <i>Circumference</i> | <i>Area</i> |
|---------------|-----------------|----------------------|---------------------|
| 13.1 cm | 26.1 cm | 82 cm | 535 cm ² |
| 2.46 m | 4.92 m | 15.5 m | 19 m ² |
| 16.5 m | 33 m | 104 m | 855 m ² |
| 7.00 mm | 14.0 mm | 44 mm | 154 mm ² |
| 3.39 mm | 6.77 mm | 21.3 mm | 36 mm ² |

(Note: all answers to to 3 s.f.)

11. (a) Circumference of circle = $2\pi r$

Half sectors form the long sides of rectangle = πr .

(b) Total area of rectangle = $l \times w$
 $= \pi r \times r$
 $= \pi r^2$

Answers

16.5 Problems in Context

1. (a) Area $A = 7.07 \text{ cm}^2$ (3 s.f.) $B = 13.5 \text{ cm}^2$ $C = 7.07 \text{ cm}^2$ (3 s.f.)
 (b) Total area = 27.7 cm^2 (3 s.f.)
2. (a) $A = 8 + 6.28 = 14.3 \text{ cm}^2$ (3 s.f.)
 (b) $A = 16 - 2 \times 3.14 = 9.72 \text{ cm}^2$ (3 s.f.)
 (c) $A = 6 + 7.1 = 13.1 \text{ cm}^2$ (3 s.f.)
3. $A = 18 + 9 + \frac{1}{4} \times \pi \times 3^2 = 34.1 \text{ m}^2$ (3 s.f.)
4. $A = 24 - 2 \times \frac{1}{2} \times \pi \times 2^2 = 11.4 \text{ cm}^2$ (3 s.f.)
5. Painted area = $2 \times (\pi \times 3.8^2 - \pi \times 1.2^2 - \pi \times 0.2^2) = 81.4 \text{ cm}^2$ (3 s.f.)
6. $A = 72 - 4 \times \frac{1}{4} \times \pi \times 3^2 = 43.7 \text{ cm}^2$ (3 s.f.) $P = 10 + 4 \times \frac{1}{4} \times 2 \times \pi \times 3 = 28.8 \text{ cm}$ (3 s.f.)
7. $A_1 = 1.27 \text{ m}^2$ (3 s.f.) $A_2 = 0.966 \text{ m}^2$ (3 s.f.) $A_3 = 1.23 \text{ m}^2$ (3 s.f.)
8. (a) 15.7 m (3 s.f.) (b) 942 m (3 s.f.)
9. (a) 265 times (3 s.f.) (b) 1380 times (3 s.f.)
10. (a) $A = 26.2 \text{ cm}^2$ (3 s.f.) $P = 20.5 \text{ cm}$ (3 s.f.)
 (b) $A = 9.24 \text{ m}^2$ (3 s.f.) $P = 12.8 \text{ m}$ (3 s.f.)

16.6 Volume and Surface Area of a Cylinder

1. $V = \pi \times 3.5^2 \times 4 = 154 \text{ cm}^3$ (3 s.f.)
2. (b) $V_A = 56.5 \text{ cm}^3$ (3 s.f.) $V_B = 50.3 \text{ cm}^3$ (3 s.f.) $V_C = 28.3 \text{ cm}^3$ (3 s.f.)
3. $A = 2 \times \pi \times 2.8 \times 7.2 + 2 \times \pi \times 2.8^2 \approx 176 \text{ cm}^2$ (3 s.f.)
4. (a) $V_A = \pi \times 2^2 \times 5 = 20 \times \pi \text{ cm}^3$ $V_B = \pi \times 4^2 \times 1.25 = 20 \times \pi \text{ cm}^3$
 (b) $A_A = 2 \times \pi \times 2 \times 5 + 2 \times \pi \times 2^2 = 88.0 \text{ cm}^2$ (3 s.f.)
 $A_B = 2 \times \pi \times 4 \times 1.25 + 2 \times \pi \times 4^2 = 132 \text{ cm}^2$ (3 s.f.)

16.6

Answers

5. (a) $\pi \times 6^2 \times h = 250 \Rightarrow h = \frac{250}{\pi \times 6^2} \approx 2.21 \text{ cm (3 s.f.)}$

(b) $A = 2 \times \pi \times 2.21 \times 6 + 2 \times \pi \times 6^2 \approx 309 \text{ cm}^2 \text{ (3 s.f.)}$

6. $\pi \times r^2 \times 9 = 300$

$$r^2 = \frac{300}{\pi \times 9}$$

$$r = \sqrt{\frac{300}{\pi \times 9}} \approx 3.2571$$

i.e. $d = 6.51 \text{ cm (3 s.f.)}$

7. (a) Tall (32 cm) and thin; short (18 cm) and fat !

(b) $r = \frac{576}{2 \times \pi \times 32} \approx 2.86 \text{ cm (3 s.f.)}$; $r = \frac{576}{2 \times \pi \times 18} \approx 5.09 \text{ cm (3 s.f.)}$

(c) $V = \pi \times 2.86^2 \times 32 \approx 822 \text{ cm}^3 \text{ (3 s.f.)}$; $V = \pi \times 5 \times 0.9^2 \times 18 \approx 1470 \text{ cm}^3 \text{ (3 s.f.)}$

8. $2 \times \pi \times r \times 11 = 40 \Rightarrow r = \frac{40}{22 \times \pi}$

$$V = \pi \times r^2 \times 11 \approx 11.6 \text{ cm}^3 \text{ (3 s.f.)}$$

9. $V = (\pi \times 5^2 - \pi \times 4^2) \times 40 \approx 1131 \text{ cm}^3 \text{ (4 s.f.)}$

10. $V = \frac{1}{2} \times (\pi \times 6^2 - \pi \times 3^2) \times 15 \approx 636 \text{ cm}^3 \text{ (3 s.f.)}$

$$A = \frac{1}{2} \times 2 \times \pi \times 6 \times 15 + \frac{1}{2} \times 2 \times \pi \times 3 \times 15 + 2 \times \frac{1}{2} \times (\pi \times 6^2 - \pi \times 3^2) + 2 \times 3 \times 15$$

$$\approx 599 \text{ cm}^3 \text{ (3 s.f.)}$$

Practice Book *UNIT 17 Units of Measure*

Answers

17.1 Estimating Metric Units of Length, Mass and Capacity

3. (a) 30 cm × 20 cm (b) 29.7 cm × 21 cm
4. (a) 4 m (b) 9 m (c) 15 m (d) 2 m
6. (a) 10 gms (b) 4 kg (c) 70 kg (d) 10 kg (e) 100 gms (f) 25 gms
7. (a) 10 ml (b) 100 ml (c) 300 ml
8. (a) 0.1 m³ (b) 15 c m³ (c) 5 c m³ (d) 20 c m³
9. No – 9 m is about the length of a double-decker bus.
10. No – the lining is about $\frac{2}{3}$ of the whole volume.
11. C
12. A
13. E

17.2 The Metric System: Conversion Between Units

1. (a) 40 mm (b) 70 mm (c) 260 mm (d) 8350 mm
 (e) 62 mm (f) 147 mm (g) 92.5 mm (h) 0.4 mm
 (i) 6 cm (j) 8 cm (k) 34 cm (l) 945 cm
 (m) 8.7 cm (n) 26.2 cm (o) 6.79 cm (p) 0.6 cm
2. (a) 700 cm (b) 1800 cm (c) 3600 cm (d) 90 400 cm
 (e) 430 cm (f) 5390 cm (g) 2838 cm (h) 9 cm
 (i) 8 m (j) 5 m (k) 7.6 m (l) 21.5 m
 (m) 3.65 m (n) 0.57 m (o) 0.776 m (p) 0.06 m
3. (a) 5 000 m (b) 11 000 m (c) 63 000 m (d) 423 000 m
 (e) 7400 m (f) 2650 m (g) 14 321 m (h) 70 m
 (i) 6 km (j) 17 km (k) 53 km (l) 4.75 km
 (m) 0.807 km (n) 0.062 km (o) 0.003 km (p) 0.0293 km
4. (a) 6000 gm (b) 8000 gm (c) 15 000 gm (d) 92 000 gm
 (e) 1700 g (f) 5470 gm (g) 2925 gm (h) 4 gm
 (i) 3 kg (j) 40 kg (k) 8.34 kg (l) 29.75 kg
 (m) 0.237 kg (n) 0.052 kg (o) 0.009 kg (p) 0.0036 kg

17.2

Answers

-
5. (a) 0.32 m (b) 6.42 m (c) 0.642 m (d) 8.88 m
 (e) 2240 mm (f) 45 000 mm (g) 32 000 cm (h) 8730 mm
6. (a) 8200 kg (b) 160 000 kg (c) 0.088 kg (d) 3.47 kg
7. (a) 3600 gm (b) 3 700 000 gm (c) 0.84 gm (d) 0.062 gm
8. (a) 250 ml (b) 22 000 ml (c) 750 ml (d) 450 ml
9. (a) 4.74 litres (b) 0.064 litres (c) 0.3 litres (d) 3.6 litres
10. (a) 0.3 kg (b) 300 gm
11. 120 times
12. (a) 750 ml (b) 0.75 litres
13. 18 sweets
14. (a) 12.5 gm (b) 16 ml (c) 6.25 gm

17.3 Estimating Imperial Units of Length, Mass and Capacity

1. (a) 5 " (b) 1 " (c) 3 " (d) $3\frac{1}{2}$ " (by measurement)
6. About 4 oz
7. About 0.5 pint
8. About 1 lb 4 oz
9. About 100×50 yds
10. Approximately 50 pints

17.4 Metric and Imperial Units

1. (a) 48 " (b) 84 " (c) 50 " (d) 103 "
 (e) 66 " (f) 72 " (g) 204 " (h) 63 360 "
 (i) 5 ' (j) 4 ' (k) 1 ' 5 " (l) 2 ' 5 "
 (m) 9 ' (n) 7 ' 11 " (o) 20 ' (p) 0.5 '
2. (a) 112 oz (b) 176 oz (c) 576 oz (d) 14 464 oz
 (e) 672 oz (f) 88 oz (g) 448 oz (h) 2208 oz
 (i) 5 lb (j) 8 lb (k) 3.5 lb = 3 lb 8 oz (l) 45 lb
 (m) 2.25 lb = 2 lb 4 oz (n) 4.8125 lb = 4 lb 13 oz (o) 0.5 lb (p) 0.25 lb

17.4

Answers

3. (a) 40 pts (b) 88 pts (c) 504 pts (d) 3296 pts
 (e) 60 pts (f) 4 pts (g) 26 pts (h) 55 pts
 (i) 7 gallons (j) 20 gallons (k) 600 gallons (l) 66 gallons
 (m) $1\frac{1}{2}$ gallons = 1 gallon 8 pts (n) 10.875 gallons = 10 gallons 7 pts
 (o) 0.25 gallons (p) 235.5 gallons = 235 gallons 4 pts

4. (a) 15 cm (b) 20 cm (c) 19 cm (d) 240 cm
 (e) 360 cm (f) 112.5 cm

5. BREST 250
 ROSCOFF 240
 ST MALO 105
 RENNES 101
 NANTES 9

6. (a) 222 gms (b) 0.222 kg (c) 8 oz

7. (a) 135 litres (b) 240 pts

8. 10.3 litres

9. 1.9 kg

| 10. | mph | km/h | mph | km/h |
|-----|------|------|------|------|
| | 30 | 48 | 60 | 96 |
| | 31.3 | 50 | 62.5 | 100 |
| | 40 | 64 | 70 | 112 |
| | 43.8 | 70 | 75 | 120 |
| | 50 | 80 | | |

| 11. | Ounces | Grams | Ounces | Grams |
|-----|--------|-------|--------|--------|
| | 0.7 | 20 | 4 | 112.5 |
| | 1 | 28.1 | 8 | 225 |
| | 1.8 | 50 | 9 | 253.1 |
| | 2 | 56.2 | 10.7 | 300 |
| | 3.6 | 100 | 14.2 | 40012. |

Practice Book *UNIT 18 Speed, Distance and Time* Answers

18.1 Speed

1. 40 mph
2. 42 mph
3. 4 m/hr
4. (a) 43 mph (b) 56 mph (c) 37.5 mph (d) 48 mph (e) 35 mph
5. 20 km/hr
6. 8 mph
7.

| | Julie | Debbie |
|-----|-----------|-----------|
| (a) | 25 wpm | 20 wpm |
| (b) | 1500 wphr | 1200 wphr |
8. (a) Fatima 60 mph
(b) Emma 30 mph
(c) Andy 40 mph
9. (a) 70 mph (b) 80 mph (c) 39 mph
10. 63 km/hr

18.2 Calculating Speed, Distance and Time

1. (a) 60 miles (b) 480 miles (c) 38 miles (d) 63 miles
(e) 250 miles (f) 16.5 miles (g) 45 miles (h) 67.5 miles
2. (a) 3 hrs (b) 6 hrs (c) 4 hrs (d) $5\frac{1}{2}$ hrs
(e) $1\frac{1}{2}$ hrs (f) 12 hrs (g) $6\frac{1}{2}$ hrs (h) $5\frac{1}{2}$ hrs
3. (a) 60 mph (b) 1 mile per minute 82 mins
4. (a) $1\frac{1}{2}$ hrs (b) $\frac{1}{2}$ hr
5. (a) 200 m (b) 720 m (c) 14 400 m or 14.4 km (d) 36 km
6. (a) (i) 35 s (ii) 400 s = 3 min 40 secs (iii) 750 s = $12\frac{1}{2}$ mins
(b) (i) 24 m (ii) 420 m (iii) 28.8 km

18.2**Answers**

-
7. (a) 8 hrs (b) 8.75 m (c) 24 mins (d) 62.5 cm
8. (a) Clare (Laura travels 132 miles) (b) Clare (36 mph) (c) 108 miles
9. (a) 250 miles (b) 50 mph
10. (a) 235 miles (b) 5 hrs (c) 47 mph

18.3 Problems With Mixed Units

1. (a) 1.67 hrs (b) 3.17 hrs (c) 1.1 hrs (d) 2.3 hrs
(e) 3.08 hrs (f) 6.03 hrs (g) 1.12 hrs (h) 2.38 hrs
2. (a) 1 hr 15 mins (b) 1 hr 12 mins (c) 3 hrs 42 mins
(d) 4 hrs 24 mins (e) 1 hr 27 mins (f) 3 hrs 39 mins
3. 72 mph
4. 48 mph
5. (a) 96 km/h (b) 154.8 km/h (c) 237.6 km/h (d) 134.4 km/h
6. (a) 36 mph (b) 51.25 mph (c) 30 mph (d) 15.75 mph
7. (a) 73.64 km/h (b) 20.45 m/s (c) 46 mph
8. (a) 55 mph (b) 377.67 miles
9. (a) $12\frac{1}{2}$ mins (b) 20 mins 50 sec or 20.83 mins (c) 2.22 hours
10. (a) $2\frac{6}{7}$ hrs \approx 2 hrs 51 mins (b) 1 hr 20 min (c) 54 min
(answers given to the nearest minute)

Answers

18.4 Distance-Time Graphs

1. (a) $150 \text{ secs} = 2\frac{1}{2} \text{ mins}$ (b) 450 m (c) $180 \text{ m/min} = 3 \text{ m/s}$
 (d) $90 \text{ secs} = 1\frac{1}{2} \text{ min}$ (e) 3.75 m/s

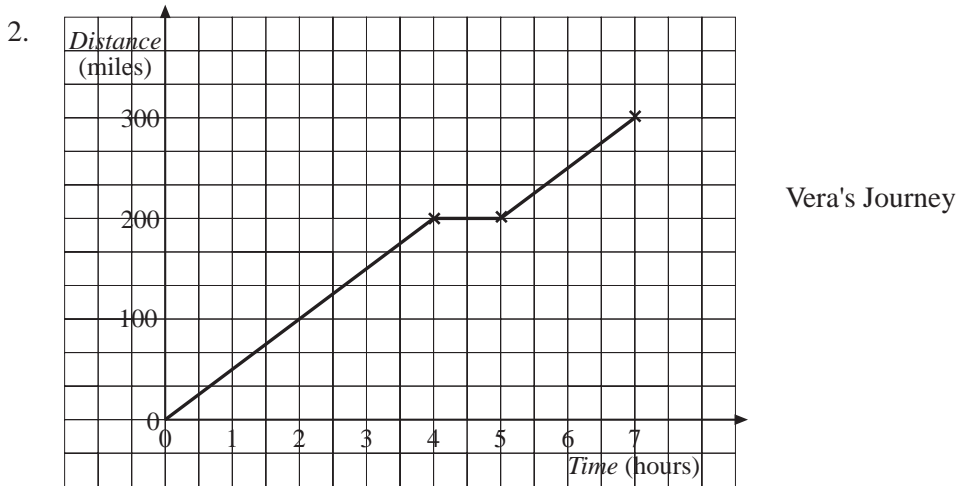

3. (a) Constant speed 100 km/h for 3 hrs
 (b) Rest for $\frac{1}{2}$ hr
 (c) Constant speed 100 km/h for 1 hr
 (d) Rest for $\frac{1}{2}$ hr
 (e) Constant speed 37.5 km/h for 4 hrs.

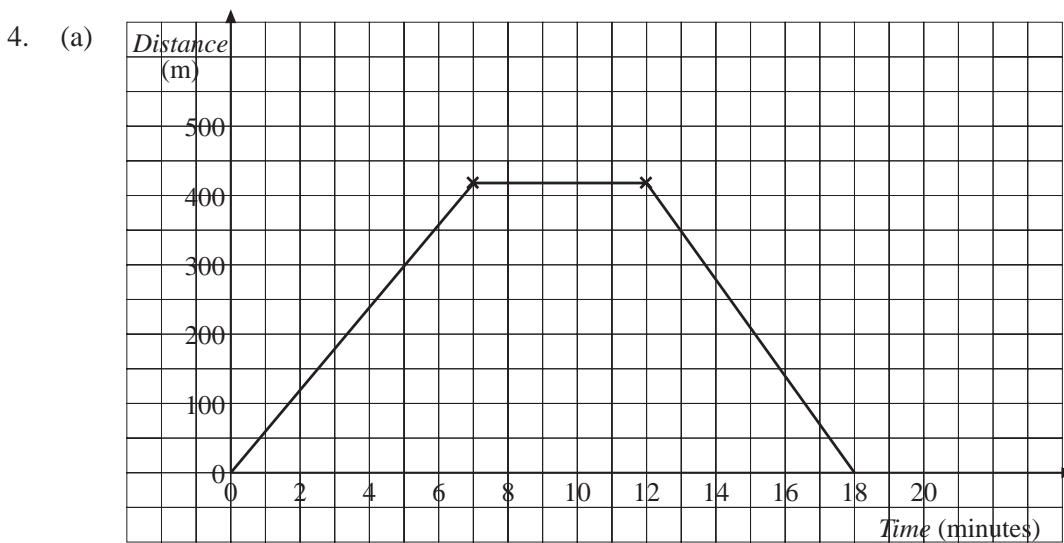

- (b) Ray walks to the shop at 60 m/minute and walks home at 70 m/minute.
 (Answers to 2 d.p.)

18.4

Answers

5. (a)

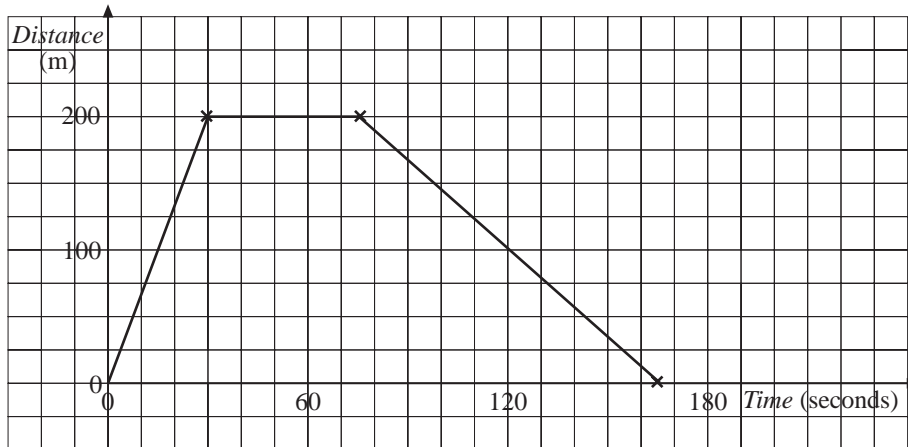

(b) Runs at $\frac{200}{30} = 6\frac{2}{3}$ m/s (≈ 6.67 m/s) (c) Walks at $\frac{200}{90} = 2\frac{2}{9}$ m/s (≈ 2.22 m/s)

6. (a) 1500 m (b) 15 mins (c) $1\frac{2}{3}$ m/s ≈ 1.67 m/s (2 d.p.)

(d) 35 mins (e) $1\frac{1}{4}$ m/s = 1.25 m/s

7. (a) 8400 m

(b)

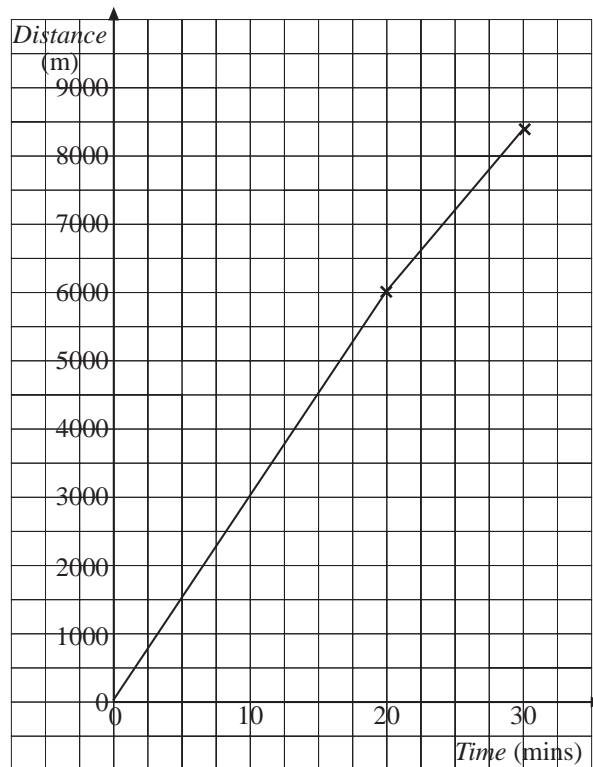

8. (a) James constant speed 100 m/min

(b) Rachel 200 m/min for 5 mins
 60 m/min for next 25 mins
 100 m/min for next 5 mins

18.4

Answers

- (c) 17.5 mins into race at 1750 m
- (d) 100 m/min
- (e) 200 m/min; 60 m/min; 100m/min
- (f) James

9. (a)

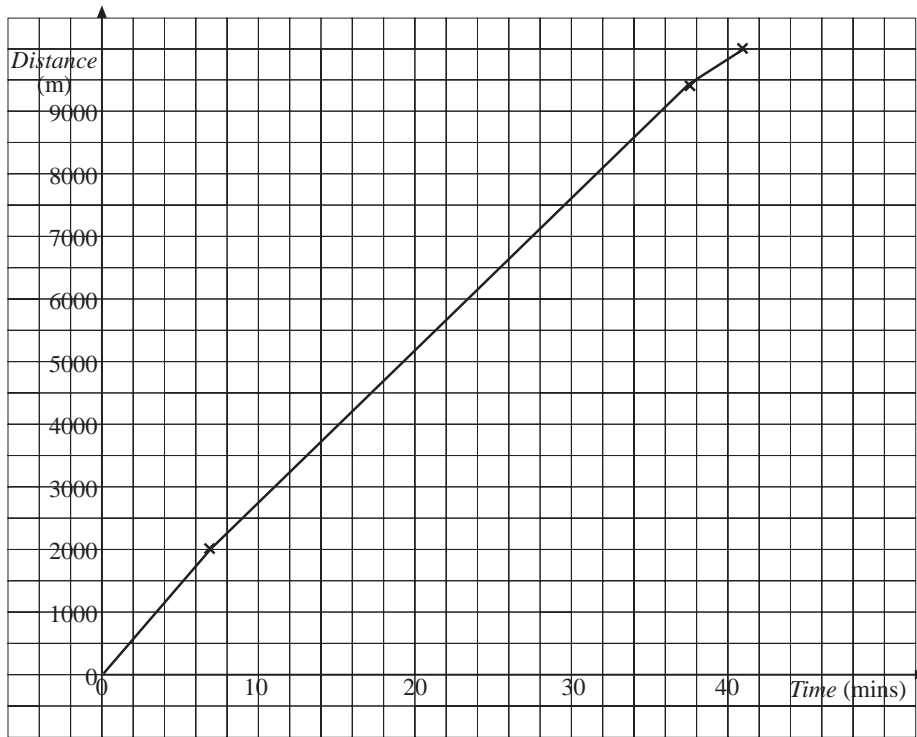

- (b) Time to complete race = $39\frac{1}{6} \approx 39.17$ mins (2 d.p.)

10. (a)

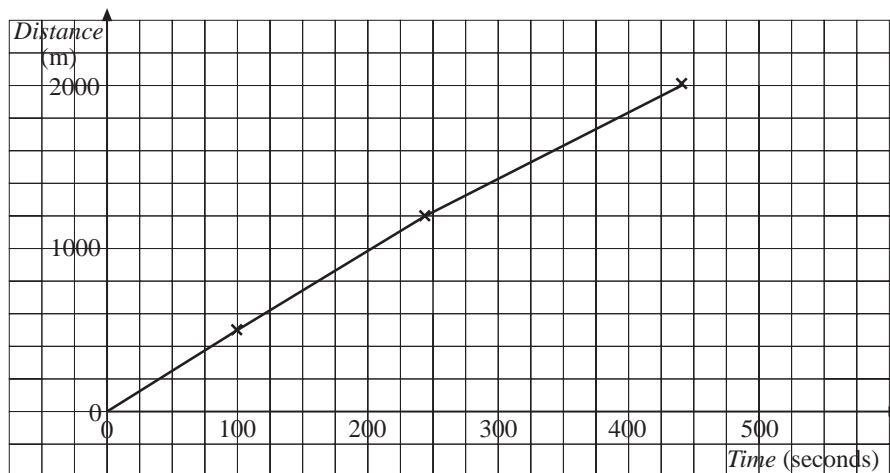

- (b) 1200 m at 5 m/s
- 800 m at 4 m/s

18.4

Answers

11. (a) Speed increasing from zero; then slowing down; stationary at destination.
 (b) Speed increasing from zero; then slowing down until stationary; then increasing again on return and slowing to start position.
 (c) Speed increasing from point away from starting position; back to start; speed rapidly increasing, back to original distance from start.
 (d) Stationary; moving at increasing speed towards 'start'; then turn around and move at reasonably constant speed away from 'start'; turn round again move steadily to distance further away from 'start' than when journey began.

18.5 Other Compound Measures

| 1. | <i>No. of Goals Scored</i> | <i>No. of Matches Played</i> | <i>Goals per Match</i> |
|--------|----------------------------|------------------------------|------------------------|
| Ian | 16 | 32 | 0.5 |
| Ben | 22 | 40 | 0.55 |
| Sergio | 9 | 20 | 0.45 |

- (a) Most goals/match = 0.55 (Ben)
 (b) Least goals/match = 0.45 (Sergio)
2. (a) 0.6 (b) 0.01 (c) 0.9
3. (a) 2.25 (b) 1.5 (c) 11.25 (d) 90
4. (a) Africa = 2.4 p/gm China = 2.675 p/gm
 (b) Africa = £1.20 p/gm China = £1.34 to nearest pence
5. First class = 0.4875 p/gm Second class = 0.3875 p/gm
6. (a) 80 p/km (b) 0.08 pence/m
7. (a) £1.98 (b) £2.76 (c) £4.71 (d) £9.39
8. (a) 93p (b) £8.56

| 9. | <i>Hours</i> | <i>Pay</i> | <i>Pay/Hour</i> |
|--------|--------------|------------|-----------------|
| Dee | 8 | 28.64 | 3.58 |
| Nadina | 12 | 43.44 | 3.62 |
| Lisa | 42 | 302.40 | 7.20 |
| Mary | 38 | 136.80 | 3.60 |
| Clare | 35 | 134.40 | 3.84 |

- (a) Most £7.20, Lisa (b) Least £3.60, Mary
10. (a) 0.2 litres/m² (b) 200 cm³/m² (c) 0.02 ml/cm²

Practice Book *UNIT 19 Similarity*

Answers

19.1 Enlargement

1. B Scale factor 2
E Scale factor 3
2. B, E
3. B Scale factor 2
C Scale factor 3
D Scale factor $\frac{1}{2}$ or 0.5
E Scale factor $1\frac{1}{2}$ or 1.5
4. C, E
5. B, E
6. C, E
7. (a) Scale factor 2

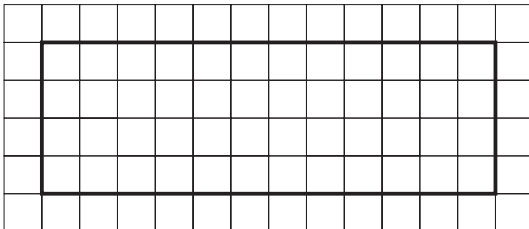

- (c) Scale factor $\frac{1}{2}$

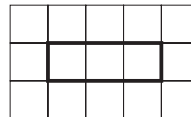

- (b) Scale factor 4

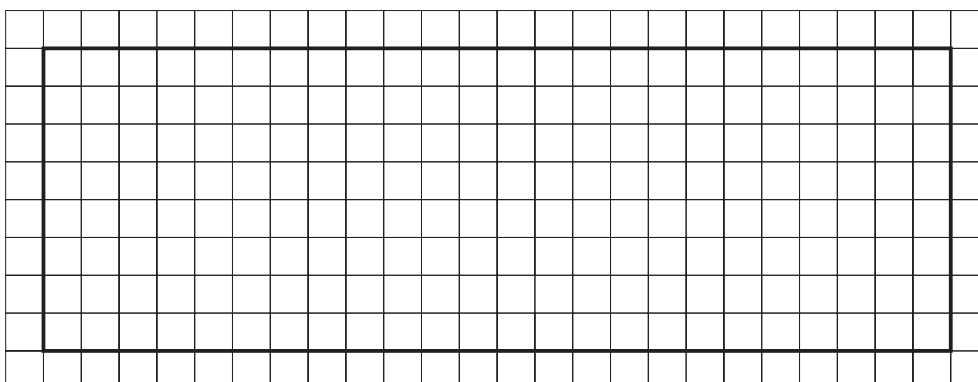

19.1

Answers

(d) Scale factor 3

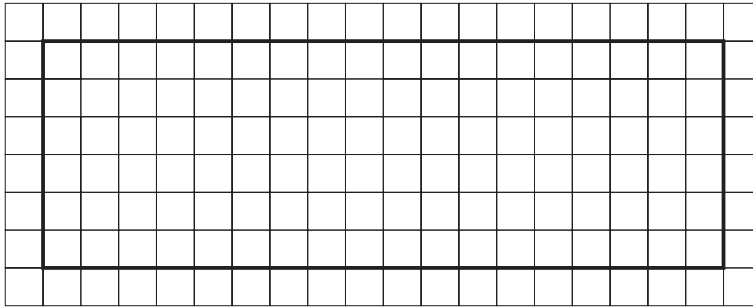

8. (a) Scale factor 2

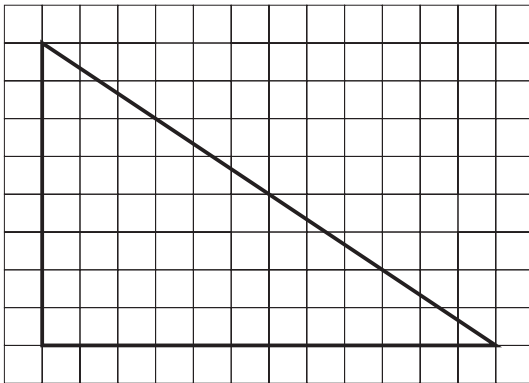

(c) Scale factor $1\frac{1}{2}$

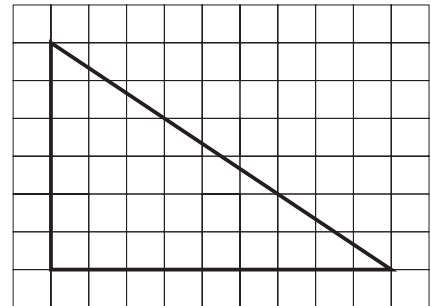

(b) Scale factor 3

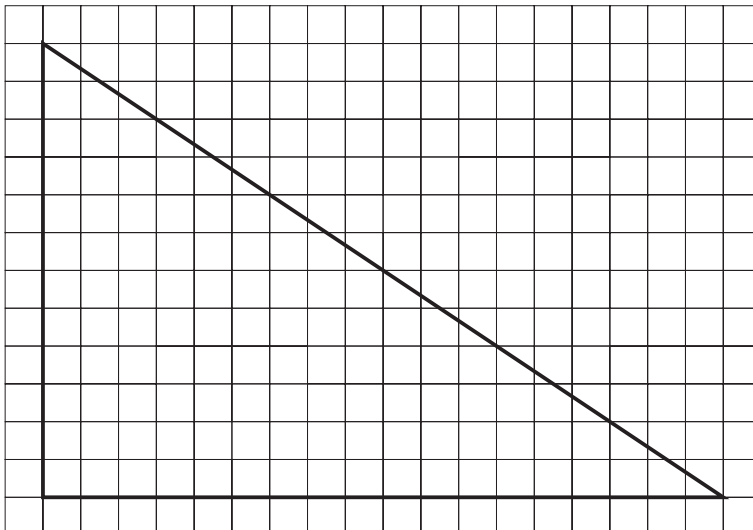

19.1

Answers

9.

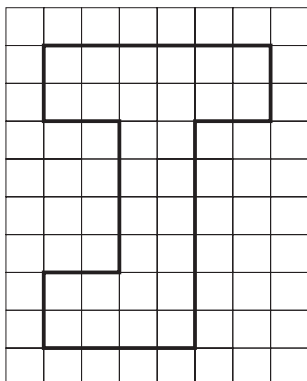

10.

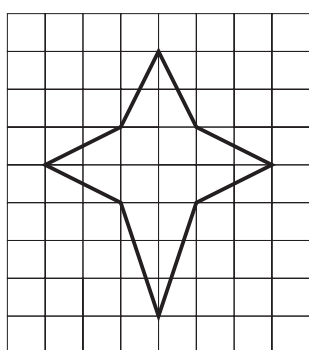

19.2 Similar Shapes

1. Scale factor = $\frac{30}{6} = 5$ $CD = 5 \times 16 = 80$ cm
2. Scale factor = $\frac{12}{6} = 2$ (a) $AB = 2 \times 2.5 = 5$ cm (b) $EF = \frac{13}{2} = 6.5$ cm
3. Scale factor = 8 (a) $DE = \frac{32}{8} = 4$ cm (b) $AC = 4 \times 8 = 32$ cm
(c) $BC = 3 \times 8 = 24$ cm
4. Scale factor = 7 $GE = 42$ cm
 $FG = 35$ cm
5. Scale factor = 2, 6 (a) $EG = 10$ cm (b) $HJ = 30$ cm
(c) $EF = 12$ cm (d) $AB = 6$ cm
6. Scale factors = $1\frac{1}{2}$, $2\frac{1}{2}$ (a) $HI = 7.5$ cm (b) $BC = 3$ cm
(c) $AC = 5$ cm (e) $DF = 7.5$ cm
7. (a) $IP = 8$ cm (b) $JK = 2$ cm (c) $LM = 2$ cm
(d) $FG = 6$ cm $NO = 4$ cm (e) $EF = 4.5$ cm

19.2

Answers

8. (a) (i) Angle A B E = angle D B C (ii) Angle B A E = angle B D C
 (iii) Angle A E B = angle B C D
 (b) A B = 16.4 cm; B E = 20 cm
9. (a) Since BE is parallel to D D, angle A E B = angel A D C and angle A B E = angle A C D. Also, angle A is common to both triangles. So triangle A B E is similar to triangle A C D.
 (b) A C = 6.6 cm , B C = 2.2 cm
 (c) A E = 9.0 cm, D E = 4.5 cm
10. Scale factor 0.6 (a) A C = $0.6 \times 15 = 9$ cm; C D = $\frac{8}{10} \times 15 = 12$ cm; D E = 3 cm
 (b) C F = $\frac{10.8}{0.6} = 18$ cm; G C = $0.8 \times 18 = 14.4$ cm; F G = 3.6 cm

19.3 Line, Area and Volume Ratios

1. (a) $12 \text{ cm}^2, 192 \text{ cm}^2$ (b) 4 (c) $4^2 = 16$
2. (a) 48 cm^2 (b) 108 cm^2 (c) 432 cm^2 (d) 1200 cm^2

3.

| <i>Length of Sides</i> | | <i>Scale Factor</i> | <i>Area</i> | <i>Area Factor</i> |
|------------------------|---------------|---------------------|---------------------|--------------------|
| <i>Base</i> | <i>Height</i> | | | |
| 3 cm | 4 cm | 1 | 6 cm^2 | 1 |
| 6 cm | 8 cm | 2 | 24 cm^2 | 4 |
| 9 cm | 12 cm | 3 | 54 cm^2 | 9 |
| 12 cm | 16 cm | 4 | 96 cm^2 | 16 |
| 15 cm | 20 cm | 5 | 150 cm^2 | 25 |
| 18 cm | 24 cm | 6 | 216 cm^2 | 36 |
| 30 cm | 40 cm | 10 | 600 cm^2 | 100 |
| 4.5 cm | 6 cm | 1.5 | 13.5 cm^2 | 2.25 |

4. Area = $25 \times 42 = 1050 \text{ cm}^2$

5. Area = $9 \times 50 = 450 \text{ cm}^2$

19.3

Answers

6. Large rectangle has sides $4 \times$ small rectangle.
7. (a) Smaller = 24 cm^3 ; Larger = 192 cm^3
 (b) Scale factor = 2
 (c) 8
 (d) $2^3 = 8$

8.

| <i>Dimensions</i> | | | <i>Scale Factor</i> | <i>Volume</i> | <i>Volume Factor</i> |
|-------------------|---------------|---------------|---------------------|------------------------|----------------------|
| <i>Width</i> | <i>Length</i> | <i>Height</i> | | | |
| 3 cm | 6 cm | 2 cm | 1 | 36 cm^3 | 1 |
| 6 cm | 12 cm | 4 cm | 2 | 288 cm^3 | 8 |
| 12 cm | 24 cm | 8 cm | 4 | 2304 cm^3 | 64 |
| 15 cm | 30 cm | 10 cm | 5 | 4500 cm^3 | 125 |
| 30 cm | 60 cm | 20 cm | 10 | $36\,000 \text{ cm}^3$ | 1000 |

9. Vol = $27 \times 32 = 864 \text{ cm}^3$
10. Vol = $(2.5)^3 \times 42 = 656.25 \text{ cm}^3$

19.4 Maps and Scale Models

1. (a) $400 \text{ cm} = 4 \text{ m}$ (b) $50\,000 \text{ cm}^2 = 5 \text{ m}^2$ (c) 3.2 m^3 ($3\,200\,000 \text{ cm}^3$)
2. (a) $50 \times 50\,000^2 = 125\,000\,000\,000 \text{ cm}^2$ (b) $12\,500\,000 \text{ m}^2$ (c) 12.5 km^2
3. 7776 m^3
4. (a) $16\,000\,000\,000 \text{ cm}^2$ (b) $1\,600\,000 \text{ m}^2$ (c) 1.6 km^2
5. (a) 6 m (b) 76.5 m^2 (c) 3898.8 m^3
6. (a) $1 : 20$ (b) 24.12 m^3 (c) 800 cm^2 or 0.08 m^2
7. 16 km^2
8. 312.5 cm^2
9. (a) 5000 (b) 600 cm^2 (c) 7500 cm^3
10. $1 : 50\,000$

Practice Book *UNIT 20 Questionnaires and Analysis Answers*

20.1 Questionnaire Design

1. to 4. Individual responses

5. (a) E.g. Do you enjoy maths?

(b) E.g. Should town centre car park charges be increased?

(c) E.g. Do you think school lunches are good value for money?

6. (a) No age ranges / specific age; derogatory terms.

Question: e.g. How old are you?

(b) Only limited choice.

Question: e.g. What is your favourite breakfast cereal?

(c) Gaps in age ranges.

Question: e.g. How old are you? 0 - 5 years

6 - 10 years

11 - 15 years

15 + years

(d) Confusing / non-specific.

Question: e.g. How many brothers do you have?

7. (a) Include questions on fuel escalator / pollution increases / congestion in city centres, etc.

(b) Include questions on new road schemes / independence of travel / speed, etc.

8. (a) Weather conditions influence modes of transport.

(b) Interviews conducted on cross-section of occasions throughout the year to include *all* possible conditions.

9. (a) Statement of days television watched gives no indication of programme schedules / personal routine / recorded programmes, etc.

(b) Specific programmes / live or recorded / weekday or weekend.

10. Individual responses to include activities / holidays / time with acquaintances, etc.

Answers

20.2 Data Display

1.

| Letter | Frequency | Angle |
|--------|-----------|--|
| P | 3 | $\frac{3}{36} \times 360^\circ = 30^\circ$ |
| R | 6 | 60° |
| S | 7 | 70° |
| T | 2 | 20° |
| V | 5 | 50° |
| W | 3 | 30° |
| Other | 10 | 100° |
| Totals | 36 | 360° |

Pie Chart Showing Registration Letter of Cars in a Car Park

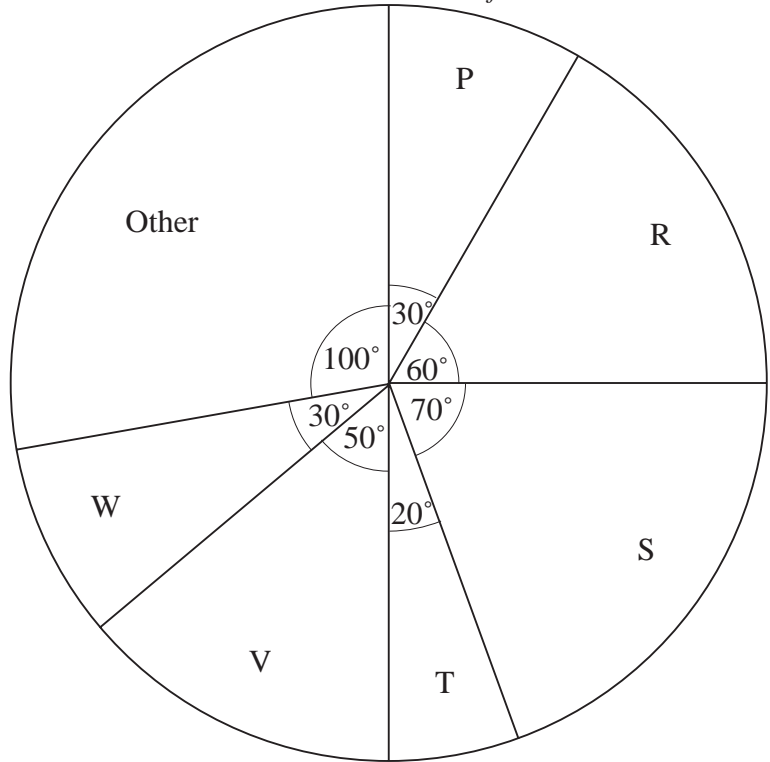

2. (a) *Vertical Line Diagram Showing Number of Bus Journeys Made by Class Members in One Week*

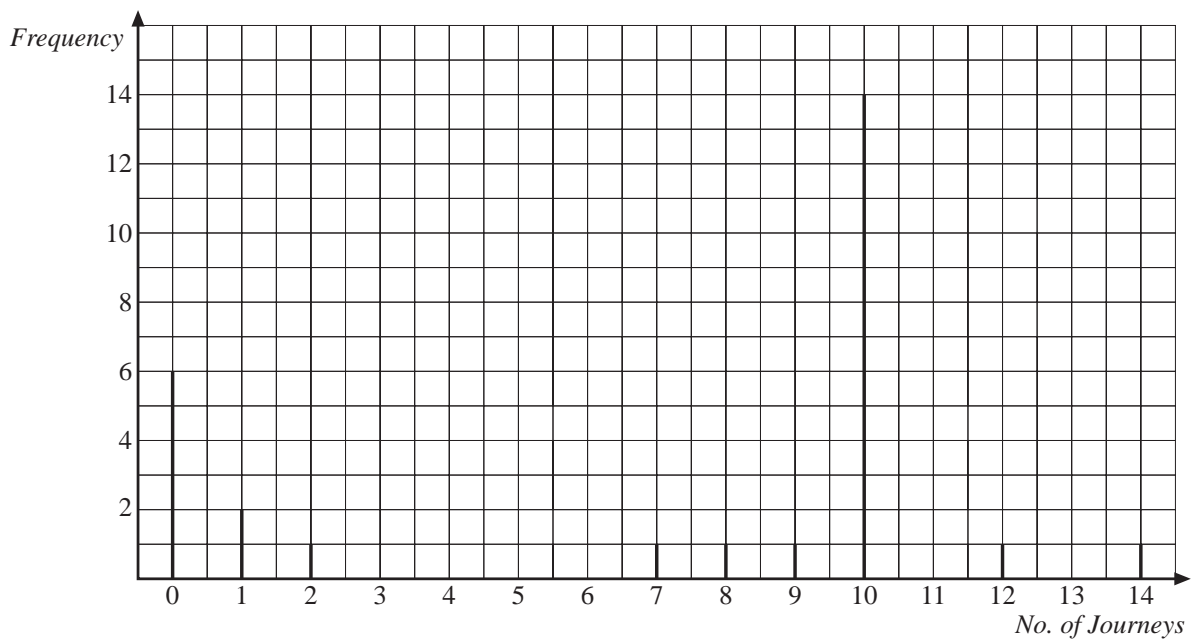

(b) School bus rides

20.2

Answers

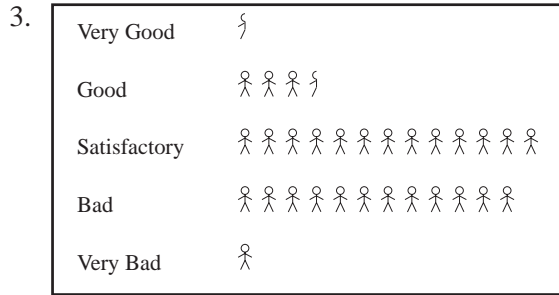

Pictogram to Show Rating of School Bus Service

↵ = 2 people

General view of services is not satisfactory.

4. (a) 19 (b) 5 (c) 17

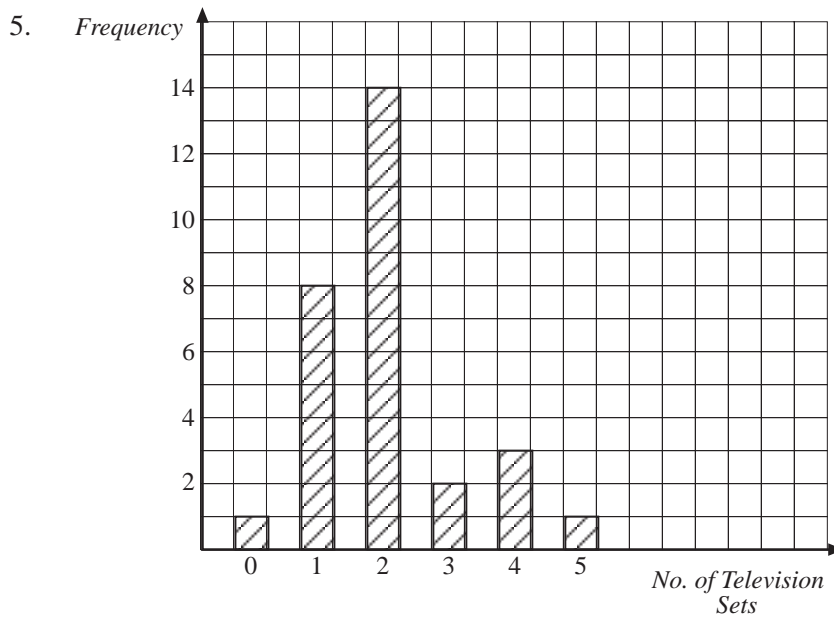

Bar Chart Showing Number of Television Sets in Each Household

Many households appear to have a main television and perhaps one more - maybe in a bedroom.

6. (a) Since he spent all his money, the pie chart shows how his spending was divided.
- (b) *Pie Chart Showing How Jason Spent His Pocket Money*

| <i>Item</i> | <i>Amount</i> | <i>Angle</i> |
|---------------|---------------|--------------|
| Sweets | 60p | 72° |
| Football club | £1.00 | 120° |
| Tennis club | 50p | 60° |
| Comics | 70p | 84° |
| New pencil | 20p | 24° |
| Totals | 300p | 360° |

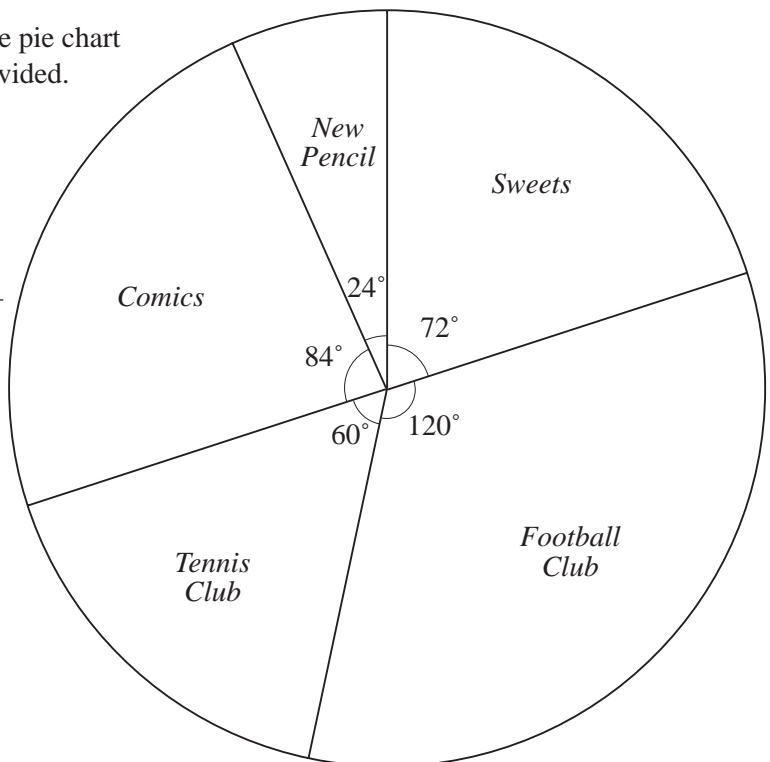

20.2

Answers

7. (a) *Pie Chart Showing Pupils' Favourite Types of Television Programme*

| <i>Programme</i> | <i>Number</i> | <i>Angle</i> |
|------------------|---------------|--------------|
| Soaps | 8 | 96° |
| Films | 9 | 108° |
| News | 1 | 12° |
| Quizzes | 2 | 24° |
| Wildlife | 4 | 48° |
| Others | 6 | 72° |
| Totals | 30 | 360° |

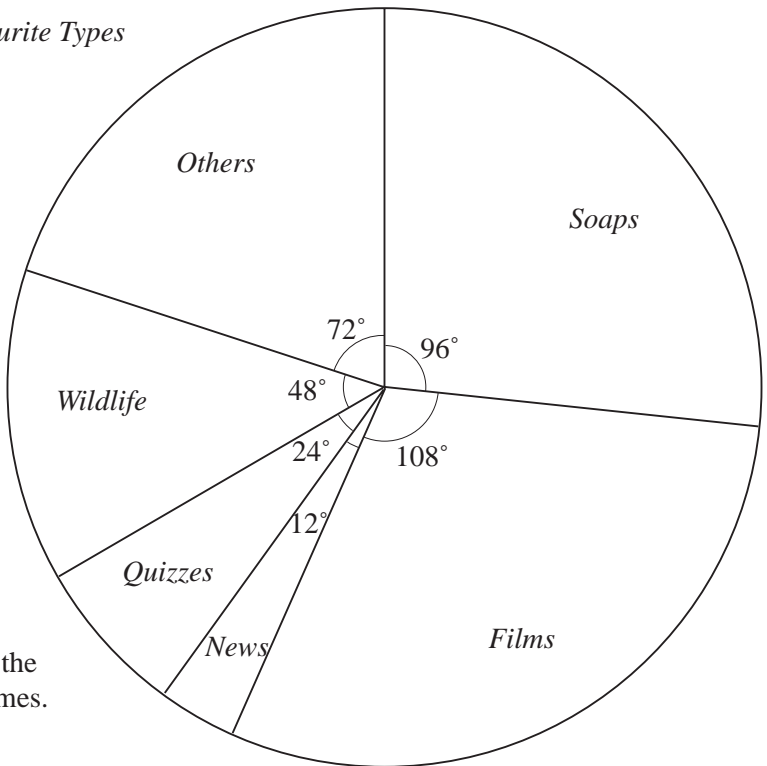

(b) Pie chart, bar chart or pictogram are all methods that give an immediate visual comparison of the relative popularity of TV programmes.

8. (a) *Bar Chart Showing Amount of Pocket Money Allocated to Pupils*

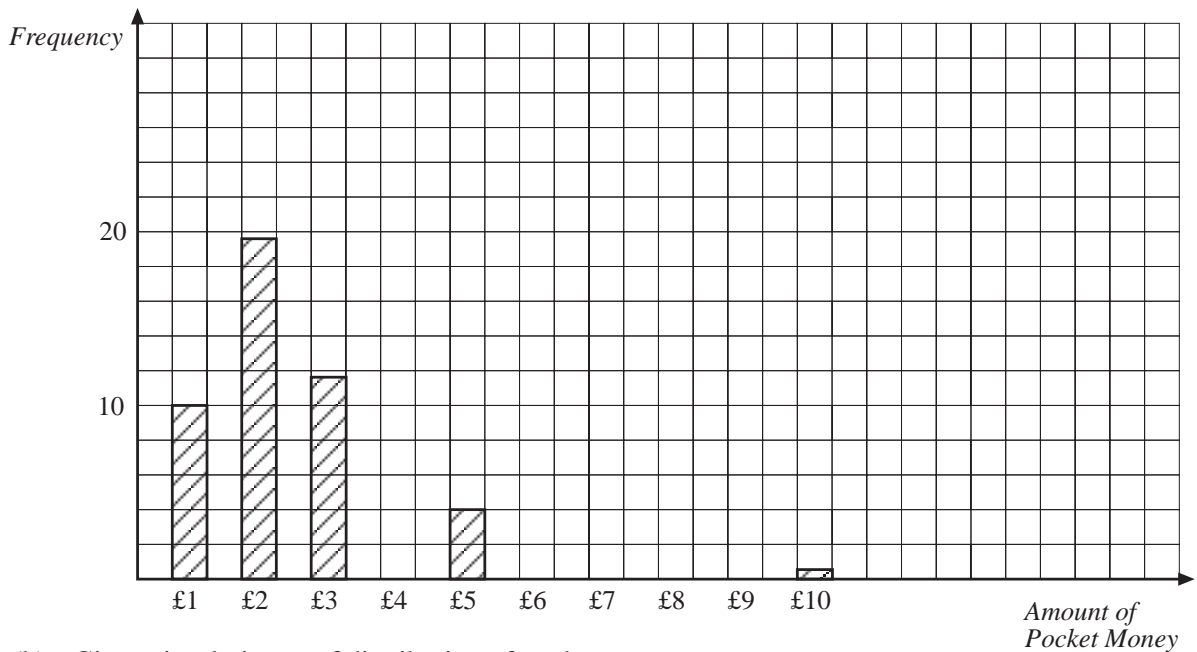

(b) Gives visual picture of distribution of pocket money.

(c) No - most pupils receive less than £4 pocket money.

9. Survey

10. Survey

Answers

20.3 Line Graphs

1. (a) *Graph Shpwing Outside Temperature Every Hour During the School Day*

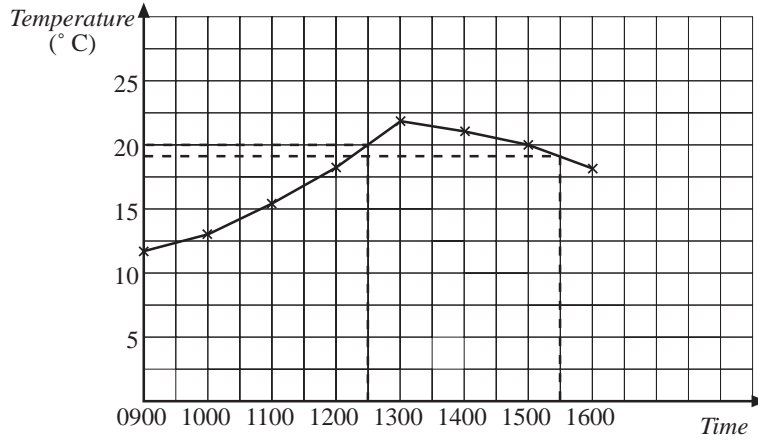

- (b) Temperature at
 1230 hours : 20 ° C
 1530 hours : 19 ° C

2. (a) *Graph Showing the Height of a Plant After Transplanting*

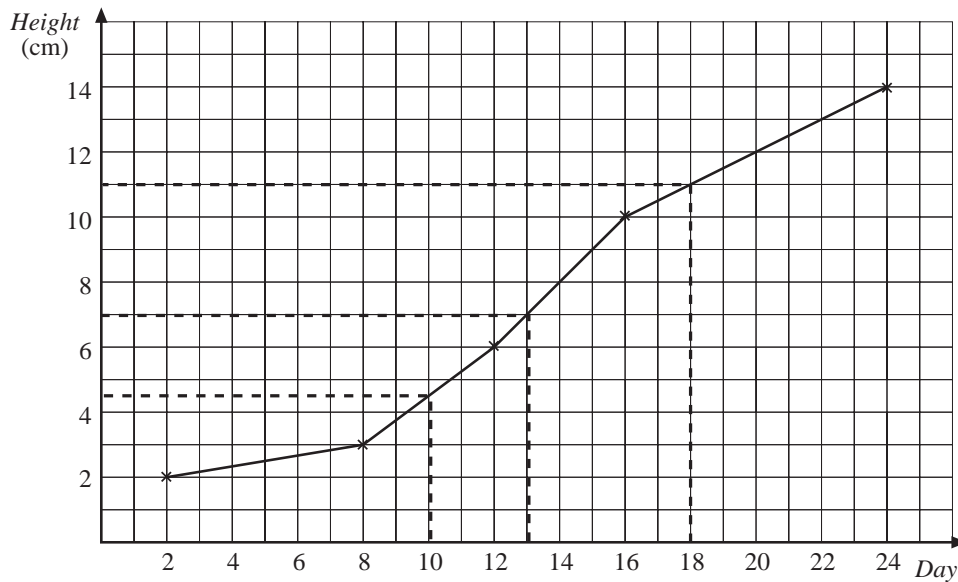

- (b) Height after
 (i) 10 days : 4.5 cm
 (ii) 18 days : 11 cm
 (iii) 13 days : 7 cm

20.3

Answers

3. (a) *Graph Showing Distance Against Time*

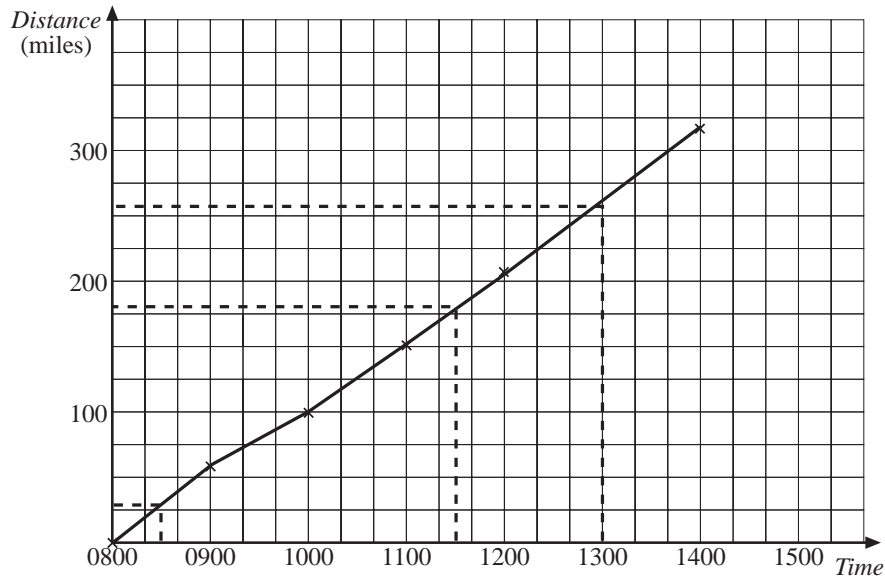

(b) Distance travelled at:

- (i) 0830 hours : 30 miles
- (ii) 1130 hours : 180 miles
- (iii) 1300 hours : 270 miles

4. *Line Graph Showing Mass of Puppy Against Age*

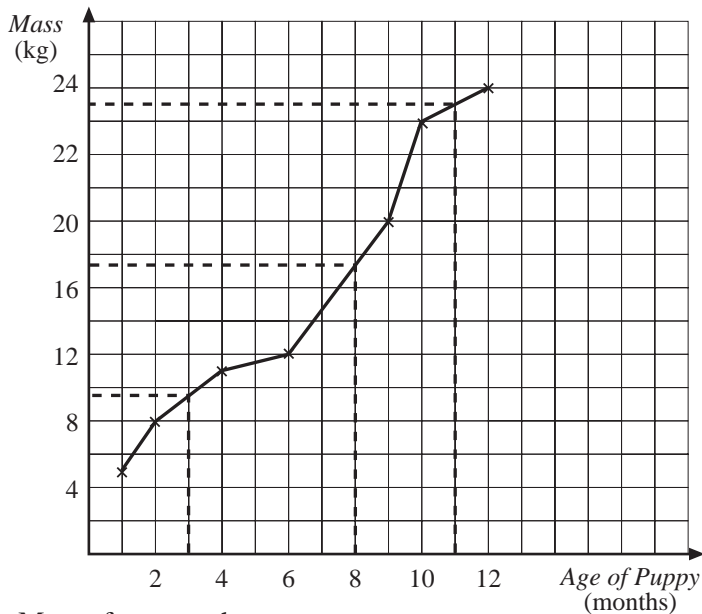

Mass of puppy when age:

- (a) 3 months : 9.5 kg
- (b) 8 months : 17.5 kg
- (c) 11 months : 23.5 kg

20.3

Answers

5. Line Graph Showing Depth of Water During Flood Alert

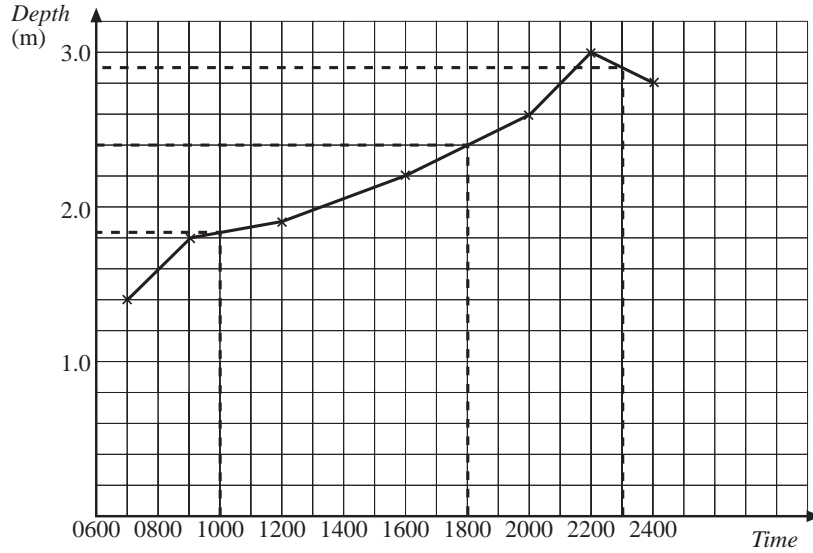

Depth of water at:

- (a) 1000 hours : 1.85 m
- (b) 1800 hours : 2.4 m
- (c) 2300 hours : 2.9 m

6. Line Graph Showing Depth of Water Recorded in Harbour During One Day

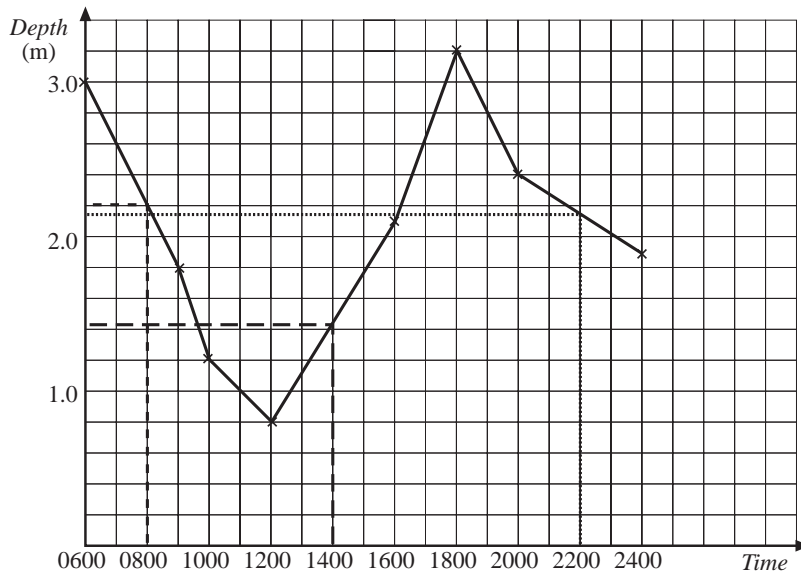

Depth of water at:

- (a) 0800 hours : 2.2 m
- (b) 1400 hours : 1.45 m
- (c) 2200 hours : 2.15 m

20.3

Answers

7. Graph Showing Patient's Temperature Whilst in Hospital

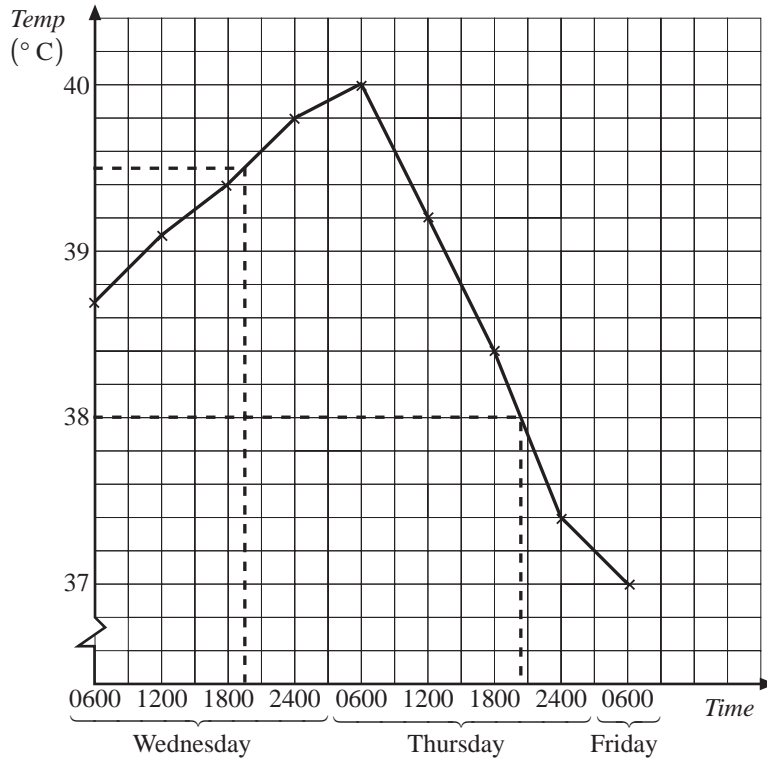

- (a) Rose above 39.5 °C at about 1930 on Wednesday.
- (b) Fell below 38 °C at about 2000 on Thursday.

8. Line Graph Showing Spring Length Against Mass

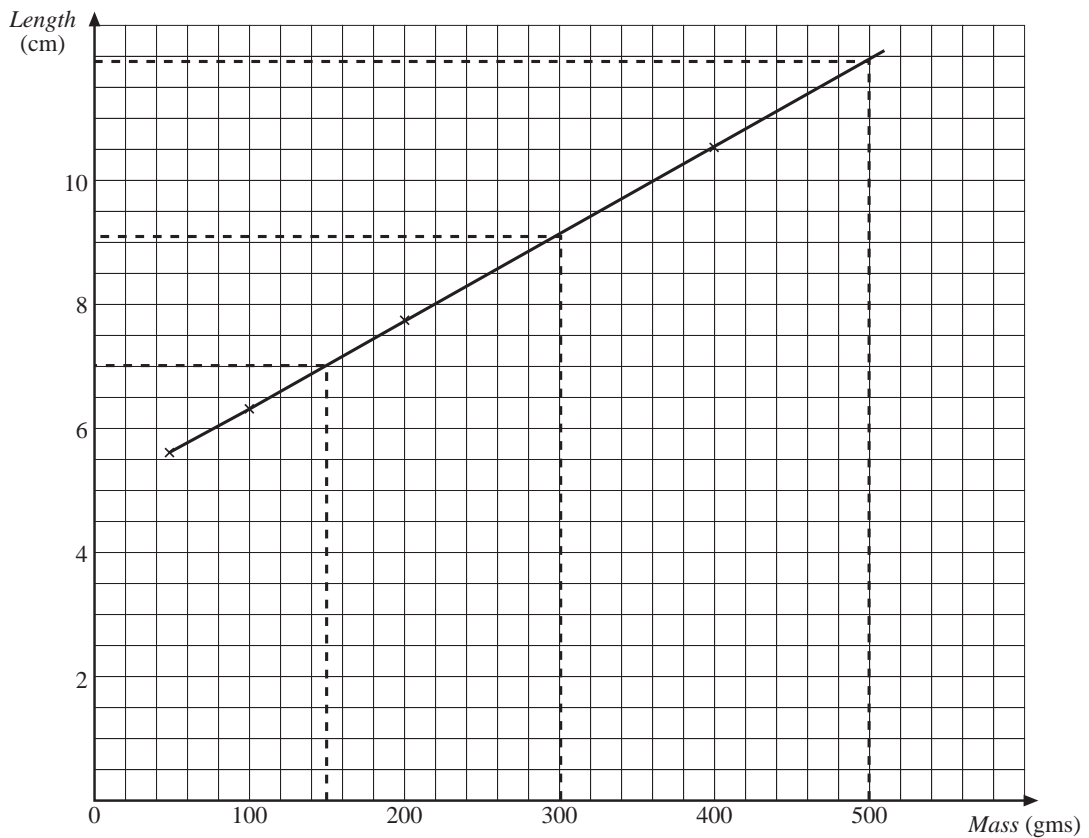

20.3

Answers

Spring length for

- (a) 150 gm mass : 7 cm
- (b) 1300 gm mass : 9.1 cm
- (c) 500 gm mass : 11.7 cm

9. Line Graph Showing Increase in Average Temperature on Earth Since 1800

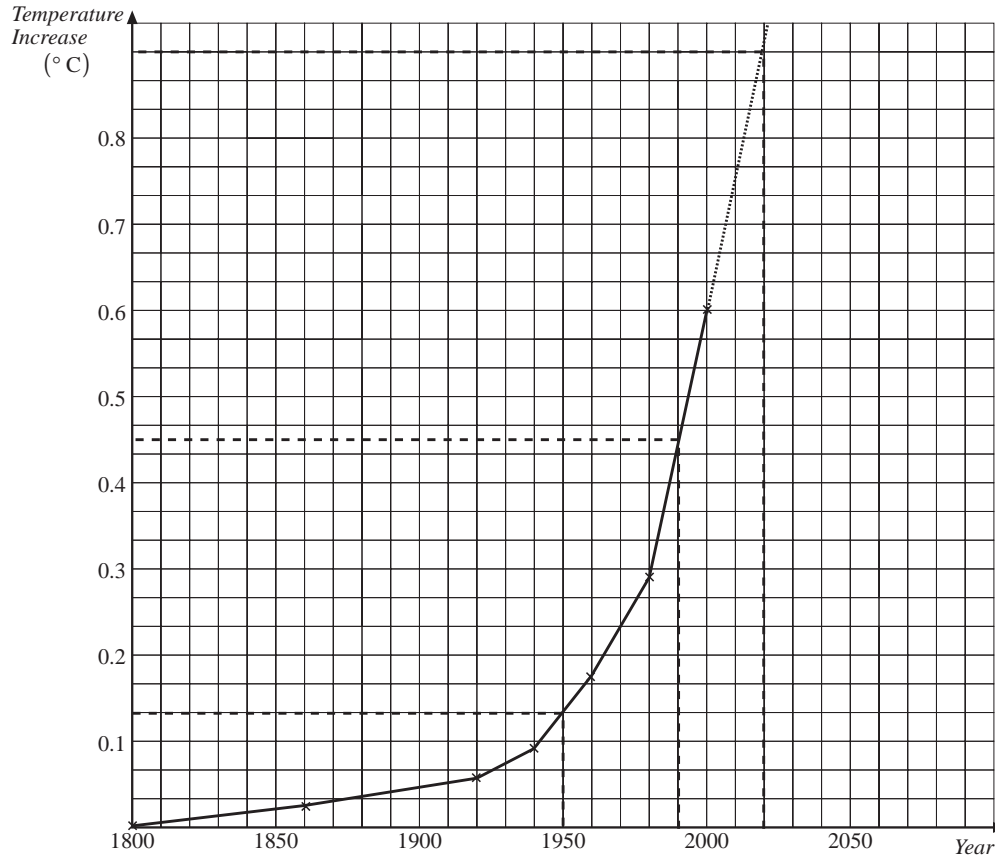

Temperature increase by

- (a) 1950 hours : 0.14
- (b) 1990 hours : 0.45
- (c) 2020 hours : 0.9

20.3

Answers

10. Graph Showing Mass Against Day of Diet

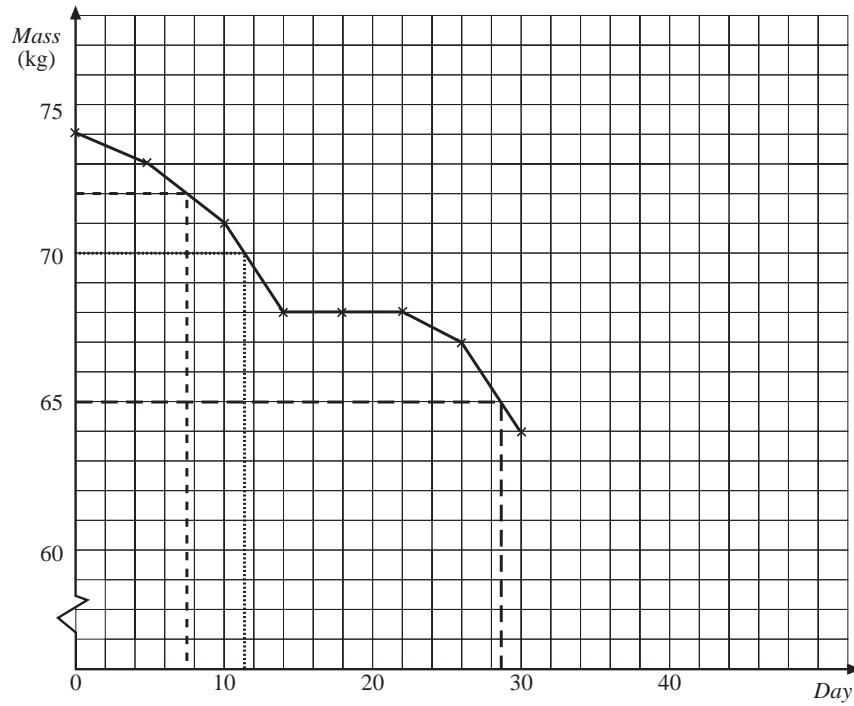

Julie's mass dropped to

- (a) 72 kg on Day 8
- (b) 70 kg on Day 12
- (c) 65 kg on Day 33

Practice Book *UNIT 1 Base Arithmetic*

Answers

1.1 Binary Numbers

1. (a) 6 (b) 15 (c) 9 (d) 13
 (e) 17 (f) 27 (g) 127 (h) 113
 (i) 170 (j) 205 (k) 455 (l) 102

2. (a) 1001 (b) 1000 (c) 1110 (d) 10001
 (e) 10010 (f) 11110 (g) 101111 (h) 110100
 (i) 1000011 (j) 1010100 (k) 11001000 (l) 111110100

3. (a) 101 (b) 1001 (c) 10001 (d) 100001

The binary equivalents always begin and end with 1 and the number of zeros in the middle increases by 1 each time.

The next base 10 number that fits this pattern is 65 (corresponding to the binary number 1000001).

4. (a) 11 (b) 111 (c) 1111 (d) 11111

The next base 10 number that fits this pattern is 63 (corresponding to the binary number 111111).

5. (a) Largest = 111, smallest = 100 (b) 7 and 4

6. Any whole number from 8 to 15

7. (a) 1100, 1010 and 1001 (b) 12, 10 and 9

8. (a) Largest = 255 (binary 11111111) (b) smallest = 128 (binary 10000000)

9. 999 converts to binary 1111100111 with 10 digits, so the binary equivalent has 7 more digits than the 3 digits in base 10.

10. The binary number 11111 is 31 in base 10, so the difference is $11111 - 31 = 11080$.

1.2 Adding and Subtracting Binary Numbers

1. (a) 100 (b) 110 (c) 1010 (d) 1001
 (e) 10101 (f) 10010 (g) 100100 (h) 100101
 (i) 11000 (j) 100101 (k) 11101 (l) 111100

2. (a) 1 (b) 100 (c) 1001 (d) 10
 (e) 1 (f) 101 (g) 111 (h) 10101
 (i) 1000 (j) 101011 (k) 10100 (l) 10111

3. (a) 110 (b) 1110 (c) 11110 (d) 111110

The answers always end in a single zero and all the other digits are ones. Also, the number of ones increases by 1 each time.

1.1

Answers

Alternatively, the answer is the binary number in the question with an extra zero on the right hand end. This is because adding a number to itself is the same as doubling, which in binary means multiplying by 10, so you just add a zero onto the right hand end of the number you are adding to itself.

4. (a) 100 (b) 1000 (c) 10000 (d) 100000

The answer always begins with 1 and the remaining digits are all zero. Also, the number of zeros increases by 1 each time.

Alternatively, the answer is the binary number in the question with an extra zero on the right hand end. Again this is because adding a number to itself is the same as doubling, which in binary means multiplying by 10, so you just add a zero onto the right hand end of the number you are adding to itself.

5. (a) 1010 (b) 111 (c) 101000 (d) 11
(e) 10111 (f) 100110

6. (a) 1 (b) 11 (c) 111 (d) 1111

The answers only involve the digit one. Also, the number of ones increases by 1 each time. The number of ones is equal to the number of zeros in the original calculation.

7. (a) $11101 \rightarrow 29$ in base 10, $1110 \rightarrow 14$ in base 10 (b) $29 + 14 = 43$
(c) $11101 + 1110 = 101011$ (d) $101011 \rightarrow 43$ in base 10

The answers to (b) and (d) are the same.

8. (a) $11101 \rightarrow 29$ in base 10, $10111 \rightarrow 23$ in base 10 (b) $29 - 23 = 6$
(c) $6 \rightarrow 110$ in binary (d) $11101 - 10111 = 110$

The answers to (c) and (d) are the same.

9. (a) 10110001 (b) 11010011 (c) 100010 (d) 100100110

10. (a) 10000 (b) 1100111

1.3 Multiplying Binary Numbers

1. (a) 1110 (check $7 \times 2 = 14$) (b) 110000 (check $12 \times 4 = 48$)
(c) 101000 (check $5 \times 8 = 40$) (d) 11101000 (check $29 \times 8 = 232$)
(e) 110000 (check $24 \times 2 = 48$) (f) 10100000 (check $20 \times 8 = 160$)
(g) 1010 (check $20 \div 2 = 10$) (h) 11 (check $12 \div 4 = 3$)

2. (a) 10101 (b) 100111 (c) 1000001 (d) 1011010
(e) 100101001 (f) 100011110 (g) 1101001 (h) 10010011
(i) 1111110 (j) 11111011

1.3

Answers

3. (a) 10010 (b) 11001 (c) 1110 (d) 1001101

4. (a) 1001 (b) 110001 (c) 11100001

The number of ones at the start increases by 1 each time, as does the number of zeros that follow. The answer always ends with a single 1. Also, the number of ones in the original number being squared is one more than the number of ones at the start of the answer, and is the same as the number of zeros that follow.

$$11111 \times 11111 = 1111000001$$

5. (a) 11001 (b) 1010001 (c) 100100001 (d) 10001000001

$$1000001 \times 1000001 = 1000010000001$$

6. (a) 1011111 (b) 1110101 (c) 10101 (d) 1001101

7. (a) 1011110100 (b) 1000000001

8. (a) 1485 (b) 10111001101 (c) $45 \rightarrow 101101$ in binary,
 $33 \rightarrow 100001$ in binary

(d) $101101 \times 100001 = 10111001101$, the same answer as part (b).

1.4 Other Bases

1. (a) 107 (b) 63 (c) 593 (d) 48
(e) 825 (f) 303 (g) 139 (h) 13

2. (a) 220 (b) 100 (c) 2241 (d) 305
(e) 626 (f) 103 (g) 12021 (h) 4432

3. (a) 11 (b) 14 (c) 12 (d) 11
(e) 14 (f) 11

4. (a) Bases 4, 5, 6, 7, 8, 9 and 10 (b) Bases 3, 4, 5, 6, 7, 8, 9, and 10
(c) Bases 9 and 10

5. (a) 102 check $13 \rightarrow (1 \times 4) + (3 \times 1) = 7$
 $23 \rightarrow (2 \times 4) + (3 \times 1) = 11$
 $102 \rightarrow (1 \times 16) + (0 \times 4) + (2 \times 1) = 18$
and $7 + 11 = 18$

(b) 434

1.4

Answers

- (c) 1101 check $222 \rightarrow (2 \times 9) + (2 \times 3) + (2 \times 1) = 26$
 $102 \rightarrow (1 \times 9) + (0 \times 3) + (2 \times 1) = 11$
 $1101 \rightarrow (1 \times 27) + (1 \times 9) + (0 \times 3) + (1 \times 1) = 37$
 and $26 + 11 = 37$
- (d) 1102
- (e) 1063 check $624 \rightarrow (6 \times 49) + (2 \times 7) + (4 \times 1) = 312$
 $136 \rightarrow (1 \times 49) + (3 \times 7) + (6 \times 1) = 76$
 $1063 \rightarrow (1 \times 343) + (0 \times 49) + (6 \times 7) + (3 \times 1) = 388$
 and $312 + 76 = 388$
- (f) 403 (g) 1322 (h) 1120
6. (a) 12 (b) 22 (c) 12 (d) 23
 (e) 11 (f) 71
7. (a) 2101 check $121 \rightarrow (1 \times 9) + (2 \times 3) + (1 \times 1) = 16$
 $11 \rightarrow (1 \times 3) + (1 \times 1) = 4$
 $2101 \rightarrow (2 \times 27) + (1 \times 9) + (0 \times 3) + (1 \times 1) = 64$
 and $16 \times 4 = 64$
- (b) 2322
- (c) 422 check $13 \rightarrow (1 \times 5) + (3 \times 1) = 8$
 $24 \rightarrow (2 \times 5) + (4 \times 1) = 14$
 $422 \rightarrow (4 \times 25) + (2 \times 5) + (2 \times 1) = 112$
 and $8 \times 14 = 112$
- (d) 3143
- (e) 4554 check $161 \rightarrow (1 \times 49) + (6 \times 7) + (1 \times 1) = 92$
 $24 \rightarrow (2 \times 7) + (4 \times 1) = 18$
 $4554 \rightarrow (4 \times 343) + (5 \times 49) + (5 \times 7) + (4 \times 1) = 1656$
 and $92 \times 18 = 1656$
- (f) 17744 (g) 20213 (h) 121121

1.4

Answers

- | | | | | |
|-----|------------|------------|------------|------------|
| 8. | (a) Base 5 | (b) Base 9 | (c) Base 9 | (d) Base 6 |
| | (e) Base 7 | (f) Base 5 | | |
| 9. | (a) Base 8 | (b) Base 3 | (c) Base 6 | (d) Base 5 |
| 10. | (a) 10211 | (b) 111 | (c) 2102 | (d) 225 |

Practice Book *UNIT 2 Basic Operations*

Answers

2.1 Place Value

- (a) (i) 180 (ii) 212 (iii) 108 (iv) 92
(b) 92, 108, 180, 212
- (a) Bird (b) Diver (c) Fish
- (a) $8 + 2 < 7 + 6$ (b) $6 - 3 = 1 + 2$ (c) $0 > -3$
- (a) £72.45 (b) £103.50 (c) £130.05
- (a) 7510 (b) 1057 (c) 105
- (a) The numbers on this number line go up in steps of 50.
(b) 80, 100, 120 (c) -10, 0, 10
(d) -3 and 13. The numbers on this number line go up in steps of 10.
(e) 7.9, 8.0 and 8.1. The numbers on this number line go up in steps of 0.1.

2.2 Addition and Subtraction

- (a) 63 (b) 50 (c) 34 (d) 148
(e) 129 (f) 170 (g) 688 (h) 459
(i) 783 (j) 758 (k) 437 (l) 1323
- (a) 62 (b) 75 (c) 42 (d) 51
(e) 22 (f) 52 (g) 19 (h) 36
(i) 19 (j) 29 (k) 591 (l) 25
- (a) 7.8 (b) 6.9 (c) 8.9 (d) 14.4 (e) 7.82
(f) 21.34 (g) 5.324 (h) 27.84 (i) 27.51
- (a) 2.3 (b) 2.1 (c) 2.5 (d) 3.11 (e) 4.61
(f) 2.51 (g) 1.53 (h) 5.12 (i) 0.88
- (a) 12 (b) 8 (c) 14 (d) 85 (e) 3
(f) 10 (g) 52 (h) 44 (i) 94 (j) 57
- (a) 486 (b) 543 (c) 3569 (d) 7604
- (a) 50 (b) 16 (c) 10 (d) 27
(e) 7 (f) 14
- 89 pupils

2.2

Answers



9. 52 people
10. (a) £20.26 (b) £4.74
11. (a) £5.53 (b) £4.47
12. 45.55 cm
13. (a) +7 (b) Choose -8, giving $-2 + (-8) = -10$
(c) Choose +9, giving $-2 - (+9) = -11$
(d) Choose -8, giving $-2 - (-8) = +6$

2.3 Multiplication and Division

1. (a) 60 (b) 1700 (c) 8000 (d) 140 (e) 3210
(f) 42 (g) 360 (h) 147 (i) 46.1
2. (a) 470 (b) 36 (c) 42.1 (d) 1.68 (e) 4.76
(f) 56 (g) 0.562 (h) 1.136 (i) 0.0652
3. (a) 90 (b) 68 (c) 574 (d) 185
(e) 114 (f) 328 (g) 192 (h) 336
(i) 768 (j) 3102 (k) 2352 (l) 1798
4. (a) 9.4 (b) 31.5 (c) 57 (d) 38.1
(d) 59.2 (f) 154.7 (g) 4.44 (h) 24.78
(i) 1.984 (j) 10.122 (k) 58.24 (l) 115.92
5. (a) 3 (b) 9 (c) 6 (d) 3
(e) 8 (f) 9 (g) 15 (h) 43
(i) 14 (j) 32 (k) 62 (l) 71
(m) 213 (n) 137 (o) 171
6. (a) 20 (b) 56 (c) 37 (d) 384
7. (a) 10 (b) 100 (c) 6 (d) 10
(e) 100 (f) 3

2.3

Answers

8. (a) £0.96 (b) £2.24 (c) £8.00
9. (a) £5.90 (b) £8.85 (c) £14.75
10. (a) 132 (b) 2200 (c) 374
11. 34
12. £10.65
13. (a) Because 9 stamps cost less than 10 stamps which cost £1.90, which is less than £2.
(b) £1.71
14. (a) £123.50
(b) $250 \div 16 = 15$ remainder 10, so Gwen can make 15 kites (with 10 staples left over).
15. (a) 45 (b) 84 (c) flower buttons (d) star buttons
(e) 4 cards of star buttons or 10 cards of flower buttons
16. (a)  (b) e.g. 
(c) 3, 8; 4, 6; 6, 4
(d) Megan is wrong because 24 is not a multiple of 5, or because she will be able to plant 4 rows of 5 seeds with 4 seeds left over, since $24 \div 5 = 4$ remainder 4.

2.4 Problems in Context

1. (a) £2.60 (b) £4.55 (c) £5.85
2. £5.73
3. (a) £31.96 (b) £79.90 (c) £71.91
4. £17.50
5. £71
6. 206 grams
7. (a) 90 miles (b) 225 miles (c) 157.5 miles

2.4

Answers

8. 9 tickets
9. (a) £2.52 (b) £2.48
10. 3 empty seats
11. (a) £33.25 (b) 14 trees (with £12 left over)
12. (a) £6.60 (b) (i) £89.60 (ii) 5 people
13. (a) Any positive multiple of 5 (b) Any other positive multiple of 5
 (c) Any other positive multiple of 5
 (d) Anna is wrong because 113 is not a multiple of 5.
 (e) Any two multiples of 5 over 100, e.g. 105 and 110
 (f) You can tell they can be divided by 5 because the last (units) digit is either 5 and 0.
14. (a) 20 packs on the bottom layer. 120 packs in the full box.
 (b) 90 packs of tea.
 (c) Total: 24 packs
 2 layers
 6 packs across (or 4) (or 12) } or reverse pairing
 2 packs wide (or 3) (or 1)
15. (a) £40 (b) £5.96 (c) 8 cassettes (with 8p change)
 (d) 3 packs (with 3p change)
 (e) 11 cassettes (3 packs of 3 and 2 single cassettes, leaving 5p change)
16. (a) 78.49 (b) 26
 (c) $102.69 \div 3.26 = 31.5$, which means that he must get a total of 31.5 from his middle three marks. The highest he can get is $3 \times 10 = 30$, so 31.5 is impossible, i.e. he cannot win with this dive.
17. (a) £7 (b) £6.10
 (c) At Milldown Funfair, Ben would get 4 rides.
 At Seaview Funfair, Ben would get 2 rides.

Practice Book *UNIT 3 Indices and Standard Form* Answers

3.1 Index Notation

- (a) 8 (b) 100 (c) 9 (d) 1000 (e) 81

(f) 27 (g) 16 (h) 81 (i) 49
- (a) $10 \times 10 \times 10 \times 10 \times 10 = 10^{\boxed{5}}$ (b) $3 \times 3 \times 3 \times 3 = 3^{\boxed{4}}$

(c) $7 \times 7 \times 7 \times 7 \times 7 = 7^{\boxed{5}}$ (d) $8 \times 8 \times 8 \times 8 \times 8 = 8^{\boxed{5}}$

(e) $5 \times 5 = 5^{\boxed{2}}$ (f) $19 \times 19 \times 19 \times 19 = 19^{\boxed{4}}$

(g) $6 \times 6 \times 6 \times 6 \times 6 \times 6 \times 6 = 6^{\boxed{7}}$ (h) $11 \times 11 \times 11 \times 11 \times 11 \times 11 = 11^{\boxed{6}}$
- (a) $8 = 2^{\boxed{3}}$ (b) $81 = 3^{\boxed{4}}$ (c) $100 = 10^{\boxed{2}}$ (d) $81 = 9^{\boxed{2}}$

(e) $125 = 5^{\boxed{3}}$ (f) $1000000 = 10^{\boxed{6}}$ (g) $216 = 6^{\boxed{3}}$ (h) $625 = 5^{\boxed{4}}$
- No, because $10^2 = 100$ and $2^{10} = 1024$.
- Yes, because $3^4 = 81$ and $4^3 = 64$.
- No, because $5^2 = 25$ and $2^5 = 32$.
- (a) $49 = \boxed{7}^2$ (b) $64 = \boxed{4}^3$ (c) $64 = \boxed{2}^6$

(d) $64 = \boxed{8}^2$ (e) $100\,000 = \boxed{10}^5$ (f) $243 = \boxed{3}^5$
- (a) 12 (b) 32 (c) 13 (d) 36

(e) 8000 (f) 1032
- (a) 625 (b) 1 (c) 27 (d) 1331
- (a) 10^5 (b) 2^{10} (c) 3^2 (d) 2^3

(e) 10^4 (f) 5^2
- (a) $k = 3, m = 6$ (b) 16 384

3.2 Laws of Indices

- (a) $2^3 \times 2^7 = 2^{\boxed{10}}$ (b) $3^6 \times 3^5 = 3^{\boxed{11}}$ (c) $3^7 \div 3^4 = 3^{\boxed{3}}$

(d) $8^3 \times 8^4 = 8^{\boxed{7}}$ (e) $(3^2)^5 = 3^{\boxed{10}}$ (f) $(2^3)^6 = 2^{\boxed{18}}$

(g) $\frac{3^6}{3^2} = 3^{\boxed{4}}$ (h) $\frac{4^7}{4^2} = 4^{\boxed{5}}$

3.2

Answers

2. (a) $a^3 \times a^2 = a^{\boxed{5}}$ (b) $b^7 \div b^2 = b^{\boxed{5}}$ (c) $(b^2)^5 = b^{\boxed{10}}$
 (d) $b^6 \times b^4 = b^{\boxed{10}}$ (e) $(z^3)^9 = z^{\boxed{27}}$ (f) $\frac{q^{16}}{q^7} = q^{\boxed{9}}$
3. $9^4 = (3^2)^4 = 3^{2 \times 4} = 3^8$
4. (a) 2 (b) 1 (c) 0 (d) 1
5. (a) $3^6 \times 3^{\boxed{11}} = 3^{17}$ (b) $4^6 \times 4^{\boxed{5}} = 4^{11}$ (c) $\frac{a^6}{a^{\boxed{2}}} = a^4$
 (d) $(z^{\boxed{3}})^6 = z^{18}$ (e) $(a^{19})^{\boxed{5}} = a^{95}$ (f) $p^{16} \div p^{\boxed{9}} = p^7$
 (g) $(p^{\boxed{5}})^8 = p^{40}$ (h) $q^{13} \div q^{\boxed{12}} = q$
6. (a) 3 (b) 2 (c) 31 (d) 24
 (e) 875 (f) 48
7. (a) $8^2 = 2^{\boxed{6}}$ (b) $81^3 = 9^{\boxed{6}} = 3^{\boxed{12}}$ (c) $25^6 = 5^{\boxed{12}}$
 (d) $4^7 = 2^{\boxed{14}}$ (e) $125^4 = 5^{\boxed{12}}$ (f) $1000^6 = 10^{\boxed{18}}$
 (g) $81 = \boxed{3}^4$ (h) $256 = \boxed{4}^4 = \boxed{2}^8$
8. (a) $8 \times 4 = 2^{\boxed{3}} \times 2^{\boxed{2}} = 2^{\boxed{5}}$ (b) $25 \times 625 = 5^{\boxed{2}} \times 5^{\boxed{4}} = 5^{\boxed{6}}$
 (c) $\frac{243}{9} = \frac{3^{\boxed{5}}}{3^{\boxed{2}}} = 3^{\boxed{3}}$ (d) $\frac{128}{16} = \frac{2^{\boxed{7}}}{2^{\boxed{4}}} = 2^{\boxed{3}}$
9. (a) False, $3^2 \times 2^2 = 6^2$ (b) False, $5^4 \times 2^3$ cannot be simplified as a single power.
 (c) True (d) False, $\frac{10^8}{5^6}$ cannot be simplified as a single power.
10. (a) $(2^6 \times 2^3)^4 = (2^9)^4 = 2^{36}$ (b) $\left(\frac{3^6}{3^2}\right)^5 = (3^4)^5 = 3^{20}$
 (c) $\left(\frac{2^3 \times 2^4}{2^7}\right)^4 = (2^0)^4 = 2^0$ (d) $\left(\frac{3^2 \times 9}{3^3}\right)^4 = (3^1)^4 = 3^4$
 (e) $\left(\frac{6^2 \times 6^8}{6^3}\right)^4 = (6^7)^4 = 6^{28}$ (f) $\left(\frac{7^8}{7^2 \times 7^3}\right)^5 = (7^3)^5 = 7^{15}$

3.3

Answers

3.3 Negative Indices

1. (a) $\frac{1}{4}$ (b) $\frac{1}{8}$ (c) $\frac{1}{1000}$ (d) $\frac{1}{49}$
 (e) $\frac{1}{64}$ (f) $\frac{1}{36}$
2. (a) $\frac{1}{49} = \frac{1}{7^2} = 7^{-2}$ (b) $\frac{1}{100} = \frac{1}{10^2} = 10^{-2}$
 (c) $\frac{1}{81} = \frac{1}{9^2} = 9^{-2}$ (d) $\frac{1}{16} = \frac{1}{2^4} = 2^{-4}$
 (e) $\frac{1}{1000000} = \frac{1}{10^7} = 10^{-7}$ (f) $\frac{1}{1024} = \frac{1}{2^{10}} = 2^{-10}$
3. (a) $\frac{7}{12}$ (b) $\frac{2}{3}$ (c) $\frac{1}{10}$ (d) $\frac{9}{1000}$
 (e) $\frac{3}{20}$ (f) $\frac{13}{42}$
4. (a) 4^1 (b) 5^4 (c) 7^{10} (d) 3^{-8}
 (e) 6^6 (f) 8^{-5} (g) 7^4 (h) 8^{18}
5. (a) $\frac{1}{9} = 3^{\boxed{-2}}$ (b) $\frac{1}{100} = 10^{\boxed{-2}}$ (c) $\frac{1}{125} = 5^{\boxed{-3}}$
 (d) $\frac{5}{5^4} = 5^{\boxed{-3}}$ (e) $\frac{6^2}{6^3} = 6^{\boxed{-1}}$ (f) $\frac{2^2}{2^{10}} = 2^{\boxed{-8}}$
6. (a) x^5 (b) x^{-2} (c) x^{-4} (d) x^{-24}
 (e) x^{-8} (f) x^{-24}
7. (a) $0.1 = 10^{\boxed{-1}}$ (b) $0.25 = 2^{\boxed{-2}}$ (c) $0.0001 = 10^{\boxed{-4}}$
 (d) $0.2 = 5^{\boxed{-1}}$ (e) $0.001 = 10^{\boxed{-3}}$ (f) $0.02 = 50^{\boxed{-1}}$
8. (a) $\frac{x^4}{x^{\boxed{2}}} = x^2$ (b) $x^6 \times x^{\boxed{-4}} = x^2$ (c) $x^9 \times x^{\boxed{-7}} = x^2$
 (d) $\frac{x^7}{x^{\boxed{9}}} = x^{-2}$ (e) $\frac{x^3}{x^{\boxed{-1}}} = x^4$ (f) $(x^3)^{\boxed{-2}} = x^{-6}$

3.3

Answers

9. (a) $\frac{1}{8} = 2^{\boxed{-3}}$ (b) $\frac{1}{25} = 5^{\boxed{-2}}$ (c) $\frac{1}{81} = 9^{\boxed{-2}}$ (d) $\frac{1}{10000} = 10^{\boxed{-4}}$

10. $a = b^3 = \left(\frac{1}{c^2}\right)^3 = (c^{-2})^3 = c^{-6}$

3.4 Standard Form

1. (a) 6210 (b) 8000 (c) 420 (d) 0.003 (e) 0.06
 (f) 0.0032 (g) 0.006 (h) 0.92 (i) 0.036
2. (a) 2×10^2 (b) 8×10^3 (c) 9×10^6 (d) 6.2×10^4
 (e) 8.4×10^5 (f) 1.2×10^{10} (g) 6.18×10^{10} (h) 3.24×10^6
3. (a) 30 000 (b) 36 000 (c) 8200
 (d) 310 (e) 16 000 (f) 172 000
 (g) 68 300 (h) 1 250 000 (i) 9170
4. (a) 4×10^{-4} (b) 8×10^{-3} (c) 1.42×10^{-1} (d) 3.2×10^{-3}
 (e) 1.99×10^{-3} (f) 6.2×10^{-8} (g) 9.7×10^{-6} (h) 2.1×10^{-13}
5. (a) 0.06 (b) 0.7 (c) 0.0018 (d) 0.004 (e) 0.0062
 (f) 0.000981 (g) 0.667 (h) 0.0000386 (i) 0.000000927
6. (a) 8×10^9 (b) 6×10^{11} (c) 4.8×10^{-4}
 (d) 2.1×10^{-11} (e) 1.22×10^2 (f) 1.28×10^{-13}
7. (a) 3×10^3 (b) 4×10^7 (c) 3×10^1
 (d) 2×10^{10} (e) 4×10^9 (f) 4×10^4
8. (a) $3600000 = 3.6 \times 10^6$ (b) $9600 = 9.6 \times 10^3$
 (c) $590000 = 5.9 \times 10^5$ (d) $0.089 = 8.9 \times 10^{-2}$
 (e) $0.0086 = 8.6 \times 10^{-3}$ (f) $0.00057 = 5.7 \times 10^{-4}$
9. (a) 7.14×10^{10} (b) 4.92×10^{11} (c) 1.62×10^{13} (d) 2.05×10^{19}
 (e) 6.144×10^{-5} (f) 2.38328×10^{44}

3.4

Answers

10. (a) 4.02×10^7 m (b) 4.02×10^9 cm (c) 4.02×10^{10} mm (d) 4.02×10^4 km
11. (a) 4.3953×10^{47} kg² (b) 1.51321×10^{11} km² (c) 3.53×10^{19} N
12. (a) Statement (i) is the true one because $4 \times 10^3 = 4000$ and $4^3 = 64$.
 (b) 0.36×10^5 (c) 25×10^{-4} (d) (i) 6×10^0 (ii) 3×10^4

3.5 Fractional Indices

1. (a) 7 (b) 8 (c) 4 (d) $\frac{1}{9}$ (e) $\frac{1}{10}$
 (f) $\frac{1}{5}$ (g) 3 (h) $\frac{1}{6}$ (i) 12
2. (a) 2 (b) $\frac{1}{2}$ (c) 5
 (d) $\frac{1}{4}$ (e) 6 (f) $\frac{1}{100}$
3. (a) 2 (b) $\frac{1}{8}$ (c) 10
 (d) $\frac{1}{3}$ (e) 5 (f) $\frac{1}{10}$
4. (a) 4 (b) 3 (c) 5 (d) $\frac{1}{5}$
5. (a) False, because $16^{\frac{1}{2}} = 4$ (b) True
 (c) False, because $9 = 81^{\frac{1}{2}}$ (d) True
6. (a) x^3 (b) a^{-5} (c) $a^{\frac{1}{2}}$ (d) $a^{-\frac{1}{2}}$
7. (a) $x^{\frac{1}{2}}$ (b) $x^{-\frac{1}{2}}$ (c) $a^{-\frac{2}{3}}$ (d) $a^{-\frac{1}{6}}$
8. (a) $2\frac{1}{2}$ (b) 2 (c) 4 (d) 2

Practice Book *UNIT 4 Fractions and Percentages* Answers

4.1 Equivalent Fractions

1. (a) $\frac{9}{12} = \frac{3}{4}$ (b) $\frac{4}{10} = \frac{2}{5}$ (c) $\frac{6}{8} = \frac{3}{4}$ (d) $\frac{9}{15} = \frac{3}{5}$

2. (a) $\frac{12}{20}$ (b) $\frac{9}{12}$ (c) $\frac{20}{35}$ (d) $\frac{10}{18}$ (e) $\frac{12}{28}$

(f) $\frac{15}{40}$ (g) $\frac{24}{30}$ (h) $\frac{8}{36}$ (i) $\frac{54}{60}$ (j) $\frac{16}{28}$

(k) $\frac{42}{66}$ (l) $\frac{40}{64}$

3. (a) $\frac{2}{3}$ (b) $\frac{1}{4}$ (c) $\frac{1}{3}$ (d) $\frac{5}{8}$ (e) $\frac{5}{6}$

(f) $\frac{1}{5}$ (g) $\frac{1}{4}$ (h) $\frac{3}{4}$ (i) $\frac{7}{50}$ (j) $\frac{3}{7}$

4. (a) $\frac{1}{2}$ (b) $\frac{2}{3}$ (c) $\frac{4}{5}$ (d) $\frac{1}{6}$ (e) $\frac{1}{5}$

(f) $\frac{2}{5}$ (g) $\frac{2}{5}$ (h) $\frac{4}{5}$ (i) $\frac{3}{4}$ (j) $\frac{2}{3}$

(k) $\frac{5}{7}$ (l) $\frac{4}{5}$

5. (a) Any two acceptable answers, e.g. $\frac{4}{14}$ and $\frac{6}{21}$

(b) Any two acceptable answers, e.g. $\frac{6}{16}$ and $\frac{9}{24}$

(c) Any two acceptable answers, e.g. $\frac{10}{18}$ and $\frac{15}{27}$

6. (a) False, because $\frac{4}{7} = \frac{12}{21}$ or because $\frac{4}{7} = \frac{16}{28}$

(b) True (c) True (d) True

7. (a) $\frac{4}{5} = \frac{32}{40}$ $\frac{5}{8} = \frac{25}{40}$ (b) $\frac{4}{5}$ is larger than $\frac{5}{8}$

8. (a) $\frac{5}{7} = \frac{15}{21}$ $\frac{2}{3} = \frac{14}{21}$ (b) $\frac{2}{3}$ is smaller than $\frac{5}{7}$

9. $\frac{1}{2} = \frac{35}{70}$ $\frac{3}{5} = \frac{42}{70}$ $\frac{4}{7} = \frac{40}{70}$ so $\frac{3}{5}$ is the largest.

10. $\frac{1}{5} = \frac{36}{180}$ $\frac{1}{4} = \frac{45}{180}$ $\frac{2}{9} = \frac{40}{180}$ $\frac{1}{2} = \frac{90}{180}$ $\frac{5}{9} = \frac{100}{180}$ so the correct order is $\frac{1}{5}, \frac{2}{9}, \frac{1}{4}, \frac{1}{2}, \frac{5}{9}$

4.2

Answers

4.2 Fractions of Quantities

1. (a) 2 (b) 4 (c) 5 (d) 4 (e) 4
 (f) 6 (g) 2 (h) 8 (i) 4
2. (a) 15 (b) 6 (c) 9 (d) 16 (e) 12
 (f) 24 (g) 20 (h) 24 (i) 20
3. 14
4. (a) 110 ml (b) 220 ml
5. (a) 120 (b) 200
6. (a) 72 miles (b) 48 miles
7. (a) 180 (b) 120
8. (a) £12 (b) £5 (c) £13
9. 108 hectares
10. 6 disks
11. (a) 3 biscuits (b) $\frac{1}{2}$ (c) 15

4.3 Operations with Fractions

1. (a) $\frac{5}{7}$ (b) 1 (c) $\frac{4}{10} = \frac{2}{5}$
 (d) $\frac{4}{5}$ (e) $\frac{6}{9} = \frac{2}{3}$ (f) 1
2. (a) $\frac{5}{6}$ (b) $\frac{9}{20}$ (c) $\frac{10}{21}$ (d) $1\frac{3}{20}$
 (e) $\frac{29}{56}$ (f) $\frac{5}{6}$ (g) $1\frac{5}{12}$ (h) $1\frac{4}{15}$
 (i) $\frac{34}{35}$ (j) $1\frac{1}{2}$ (k) $\frac{19}{24}$ (l) $1\frac{19}{30}$

4.3

Answers

3. (a) $\frac{1}{6}$ (b) $\frac{8}{15}$ (c) $\frac{1}{12}$ (d) $\frac{5}{8}$
 (e) $\frac{4}{7}$ (f) $\frac{3}{32}$ (g) $\frac{2}{5}$ (h) $\frac{1}{2}$
 (i) $\frac{5}{12}$ (j) $\frac{2}{7}$ (k) $\frac{3}{8}$ (l) $\frac{7}{12}$

4. (a) $1\frac{1}{2}$ (b) $1\frac{1}{8}$ (c) $1\frac{1}{5}$ (d) $1\frac{2}{3}$
 (e) $\frac{4}{7}$ (f) $\frac{5}{6}$ (g) $\frac{2}{5}$ (h) $\frac{14}{15}$
 (i) $\frac{5}{7}$ (j) $\frac{2}{3}$ (k) $\frac{7}{16}$ (l) $1\frac{1}{6}$

5. (a) $3\frac{3}{8}$ (b) $3\frac{1}{3}$ (c) $4\frac{1}{12}$ (d) $4\frac{1}{3}$
 (e) $3\frac{3}{4}$ (f) $1\frac{4}{5}$

6. Area = $\frac{3}{10} \text{ m}^2$ Perimeter = $2\frac{3}{10} \text{ m}^2$

7. $\frac{1}{6}$ acre

8. $\frac{3}{4} \div \frac{1}{2} = 1\frac{1}{2}$ is larger than $\frac{3}{4} \times \frac{1}{2} = \frac{3}{8}$

9. (a) $x = \frac{2}{3}$ (b) $x = 3\frac{3}{4}$

10. $2\frac{1}{4} \text{ m}$

11. (a) $\frac{1}{4} + \frac{1}{8} + \frac{1}{16} = \frac{4}{16} + \frac{2}{16} + \frac{1}{16} = \frac{7}{16}$ (b) £60

12. (a) He was wrong because $\frac{1}{3}$ of the square is smaller than $\frac{1}{3}$ of the rectangle. He actually added on $\frac{1}{2}$ of the square.

(b) $\frac{1}{3}$ (c) $\frac{1}{7}$ (d) $\frac{1}{n-1}$

4.4

Answers

4.4 Fraction, Decimal and Percentage Equivalents

1. (a) 0.6 (b) 0.7 (c) 0.2 (d) 0.45
(e) 0.31 (f) 0.82 (g) 0.14 (h) 0.04
(i) 0.63 (j) 0.02 (k) 0.01 (l) 0.19
2. (a) $\frac{4}{5}$ (b) $\frac{1}{4}$ (c) $\frac{2}{5}$ (d) $\frac{7}{20}$
(e) $\frac{13}{20}$ (f) $\frac{1}{25}$ (g) $\frac{16}{25}$ (h) $\frac{41}{50}$
(i) $\frac{7}{25}$ (j) $\frac{3}{50}$ (k) $\frac{7}{100}$ (l) $\frac{23}{25}$
3. (a) 74% (b) 99% (c) 50% (d) 6% (e) 26%
(f) 2% (g) 30% (h) 0.2% (i) 4.2%
4. (a) $\frac{1}{2}$ (b) $\frac{1}{4}$ (c) $\frac{2}{5}$ (d) $\frac{7}{10}$
(e) $\frac{31}{50}$ (f) $\frac{11}{25}$ (g) $\frac{37}{100}$ (h) $\frac{1}{25}$
(i) $\frac{1}{20}$ (j) $\frac{6}{25}$ (k) $\frac{1}{10}$ (l) $\frac{37}{50}$
5. (a) 0.5 (b) 0.75 (c) 0.8 (d) 0.45
(e) 0.7 (f) 0.03 (g) 0.19 (h) 0.46
(i) 0.28 (j) 0.32 (k) 0.125 (l) 0.625
6. (a) 90% (b) 17% (c) 56% (d) 15%
(e) 40% (f) 60% (g) 45% (h) 9%
(i) 1% (j) 6% (k) 87.5% (l) 3.5%

4.4

Answers

7.

| <i>Fraction</i> | <i>Decimal</i> | <i>Percentage</i> |
|-----------------|----------------|-------------------|
| $\frac{4}{5}$ | 0.8 | 80% |
| $\frac{17}{25}$ | 0.68 | 68% |
| $\frac{17}{20}$ | 0.85 | 85% |
| $\frac{19}{25}$ | 0.76 | 76% |
| $\frac{8}{25}$ | 0.32 | 32% |
| $\frac{3}{100}$ | 0.03 | 3% |
| $\frac{1}{200}$ | 0.005 | 0.5% |

8. Labour 55%
 Conservative 40%
 Other 5%

9. (a) 2.5% (b) 97.5%

10. 82.5%

11. (a) (i) 30% (ii) 20%
 (b) (i) $\frac{1}{2}$ (ii) $\frac{3}{8}$

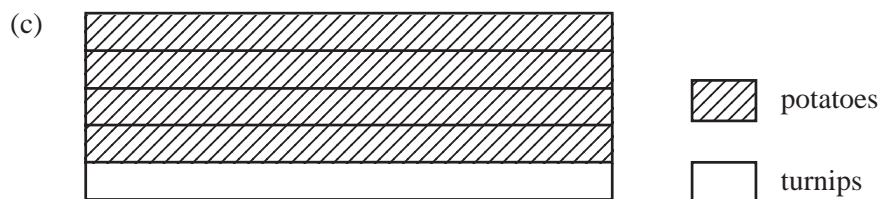

About $\frac{1}{5}$ of the patch is for turnips.

12. (a) $\frac{3}{10}$ is shaded. 30% is shaded.
 (b) Any 4 triangles shaded (or the equivalent)
 40% is shaded.

4.5

Answers

4.5 Percentage Increases and Decreases

1. (a) £120 (b) £520 (c) £100 (d) £53
 (e) 41.2 kg (f) 267.5 m
2. (a) £42 (b) 7.6 m (c) 72 kg (d) £35.20
 (e) 88.2 m (f) 315 kg
3. (a) £63 (b) £15.75 (c) £25.20
4. £30.90
5. John Smith £24 960
 Alice Holland £23 400
 Graham Hall £14 560
 Emma Graham £8 840
6. £52.50
7. (a) £235 (b) £82.25 (c) £49.35
8. (a) 7.84 m (b) 7.44 m (c) 7.04 m
9. Coat £18.20 Jeans £27.30
 Trainers £23.40 Shirt £9.10
10. £155.52
11. (a) 10% of 240 is 24
 5% of 240 is 12
 $2\frac{1}{2}\%$ of 240 is 6
 $17\frac{1}{2}\%$ of £240 is £42
- (b) 10% of 250 is 25
 10% of 250 is 25
 10% of 250 is 25
 5% of 250 is 12.5
 35% of £250 is £87.50
12. (a) $100\% - 26.1\% = 73.9\%$
 $73.9\% \text{ of } 17.6 = \frac{73.9}{100} \times 17.6 = 13.0064$
- (b) Fall = $17.0 - 12.2 = 4.8$
 Percentage fall = $\frac{4.8}{17.0} \times 100 = 28.2\%$ (to 1 decimal place)

4.5

Answers

13. (a) South America

(b) $\frac{13209}{148355} \times 100 = 8.9\%$ (to 1 decimal place)

(c) $30\% = 150 \text{ million km}^2$

$1\% = 5 \text{ million km}^2$

Total area = $100\% = 500 \text{ million km}^2$

14. (a) In 1996 they employed 10% more people, and 10% of 4000 = 400, so Tony was correct about 1996.

The workforce increased to 4400 in 1996, so in 1997 they employed an extra 10% of 4400, i.e. an extra 440, bringing the workforce to 4840. So Tony was wrong about 1997.

(b) Calculation (v) 4000×1.1^2

(c) Number of employees in 1997 = $n \times 0.8 \times 1.1 = 0.88n$

15. (a) $\pounds 19.95 \times 0.85 \times 0.85 = \pounds 14.413875 = \pounds 14.41$ (to nearest penny)

(b) $\pounds 41.48 \div 0.85 = \pounds 48.80$

(c) $\pounds 49.95 \times 0.85 \times 0.85 \times 0.85 \times 0.85 = \pounds 49.95 \times 0.85^4$
 $= \pounds 26.07$ (to nearest penny)

(d) Each day the price is 88% of the previous day's price.

For 2 days, the price is $0.88^2 = 77.44\%$ of the original price

For 3 days, the price is $0.88^3 = 68.15\%$ of the original price

For 4 days, the price is $0.88^4 = 59.97\%$ of the original price

For 5 days, the price is $0.88^5 = 52.77\%$ of the original price

For 6 days, the price is $0.88^6 = 46.44\%$ of the original price

So it takes 6 days for the original prices to be reduced by more than 50%.

Practice Book *UNIT 5 Linear Graphs and Equations* Answers

5.1 Coordinates

1. A (1, -2) B (-4, 0) C (-2, -3) D (3, 2)
 E (1, 4) F (0, 2) G (-2, 3) H (0, -5)

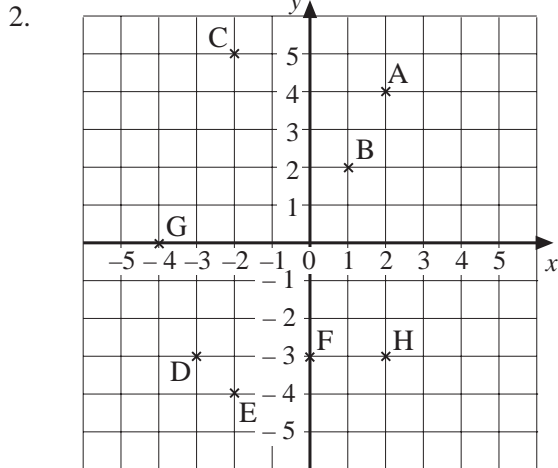

The points A, B and E all lie on a straight line through the origin.

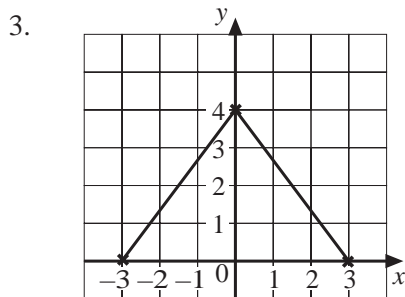

The shape is an isosceles triangle.

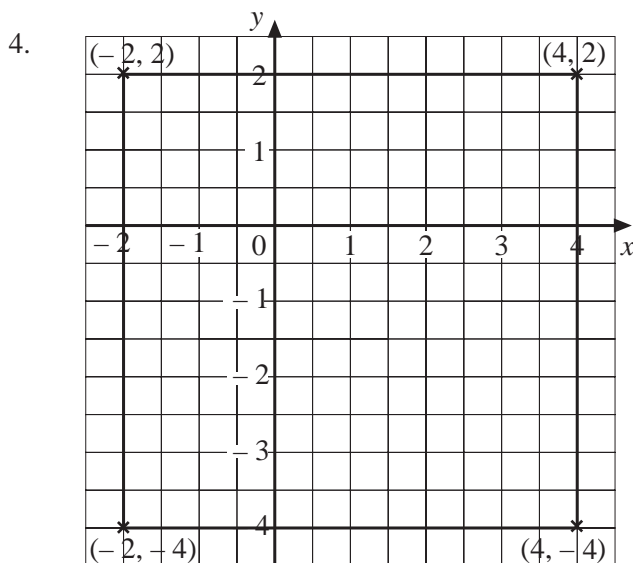

Remaining corner (-2, -4).

5.1

Answers

5.

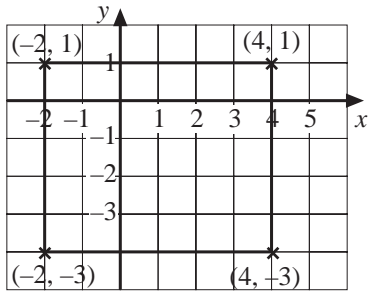

Remaining corner (4, -3)

6. (a) 3 units (b) (-1, -2), (2, -2) and (-1, 4), (2, -4)

7. (a) (8, 8) (b) (40, 40) because both coordinates are equal to double the tile number
 (c) Daniel is wrong because 25 is an odd number and all the corners with a ● have even numbers.

(d)

| Tile Number | Coordinates of the Corner with a ✕ |
|-------------|------------------------------------|
| 1 | (2, 1) |
| 2 | (4, 3) |
| 3 | (6, 5) |
| 4 | (8, 7) |

(e) Tile number 7 has a cross in the corner at (14, 13).

(f) Tile number 10 has a cross in the corner at (20, 19).

8. (a) and (b)

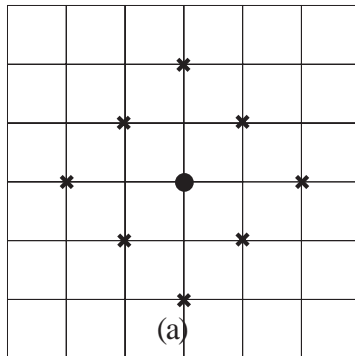

(c) 1st Step S W W
 2nd Step W S W
 3rd Step W W S

5.2

Answers

5.2 Straight Line Graphs

1. (a)

| | | | | | | |
|-----|----|----|----|---|---|---|
| x | -2 | -1 | 0 | 1 | 3 | 5 |
| y | -6 | -4 | -2 | 0 | 4 | 8 |

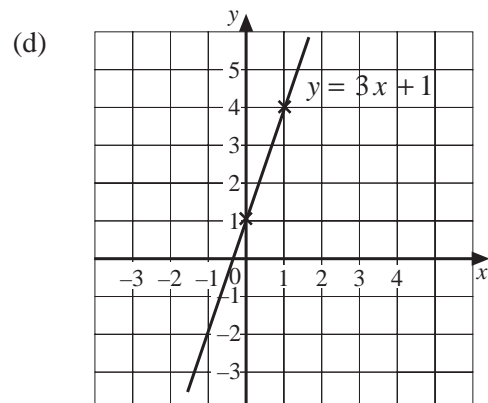
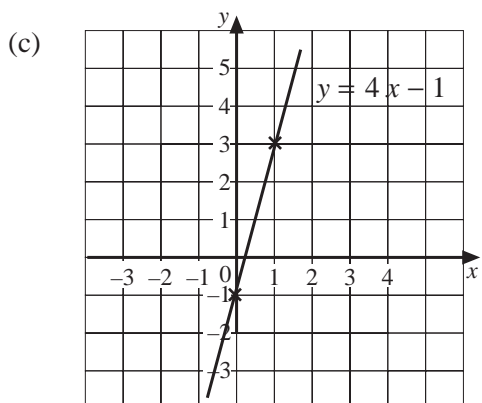
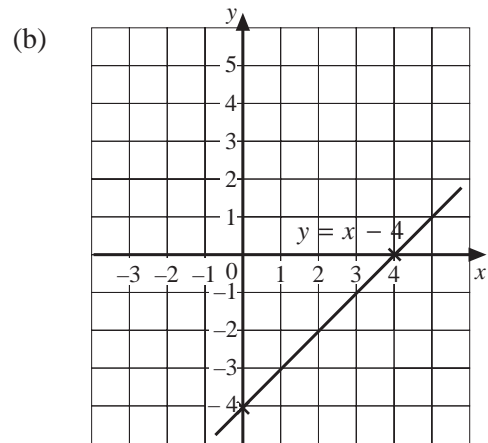
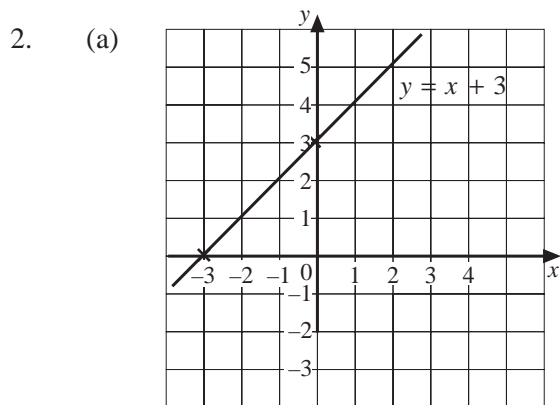
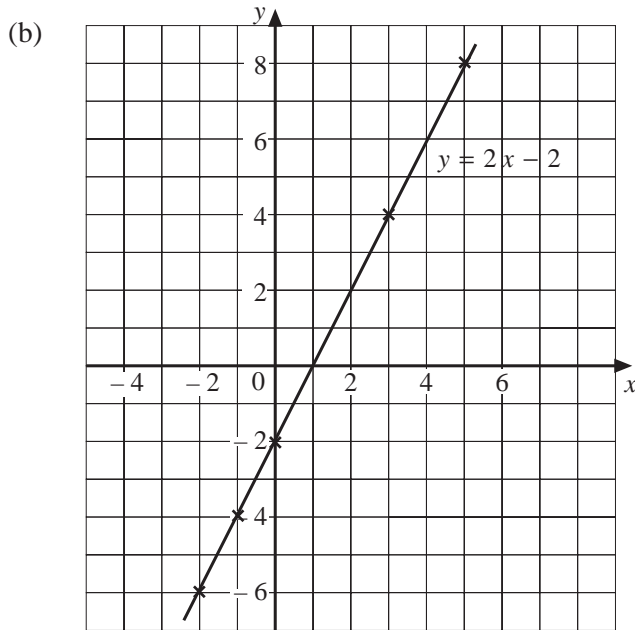

5.2

Answers

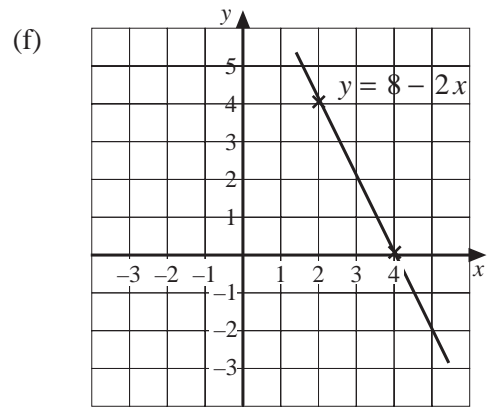
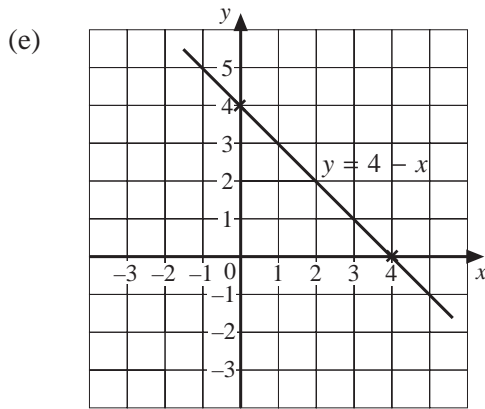

3. (a) 1 (b) 3 (c) 2 (d) 4 (e) -2
 (f) $\frac{1}{2}$ (g) $-\frac{1}{2}$

4. (a) $y = 4x + 2$ (b) $y = 2x - 5$ (c) $y = \frac{1}{2}x + 1$ (d) $y = -x - 5$

5.

| Equation | Gradient | Intercept |
|------------------------|---------------|-----------|
| $y = 5x + 7$ | 5 | 7 |
| $y = 3x - 2$ | 3 | -2 |
| $y = -3x + 2$ | -3 | 2 |
| $y = -4x - 2$ | -4 | -2 |
| $y = 2x + 3$ | -2 | 3 |
| $y = \frac{1}{2}x + 1$ | $\frac{1}{2}$ | 1 |
| $y = 4 - x$ | -1 | 4 |
| $y = 10 - 3x$ | -3 | 10 |

6. (a)

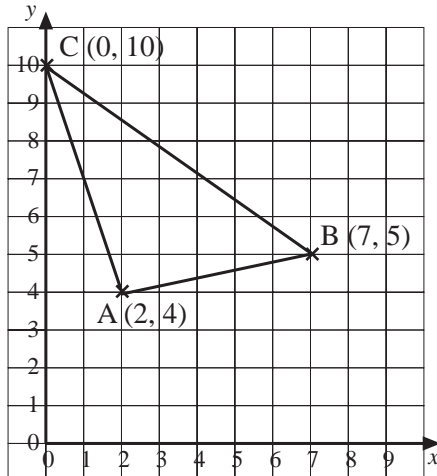

- (b) Gradient AB = $\frac{1}{5}$
 AC = -3
 BC = $-\frac{5}{7}$

5.2

Answers

7. (a) $y = 2x$ (b) $y = x - 4$ (c) $y = \frac{1}{2}x + 2$
 (d) $y = 2 - x$ (e) $y = 4x - 3$ (f) $y = -\frac{1}{3}x - 2$

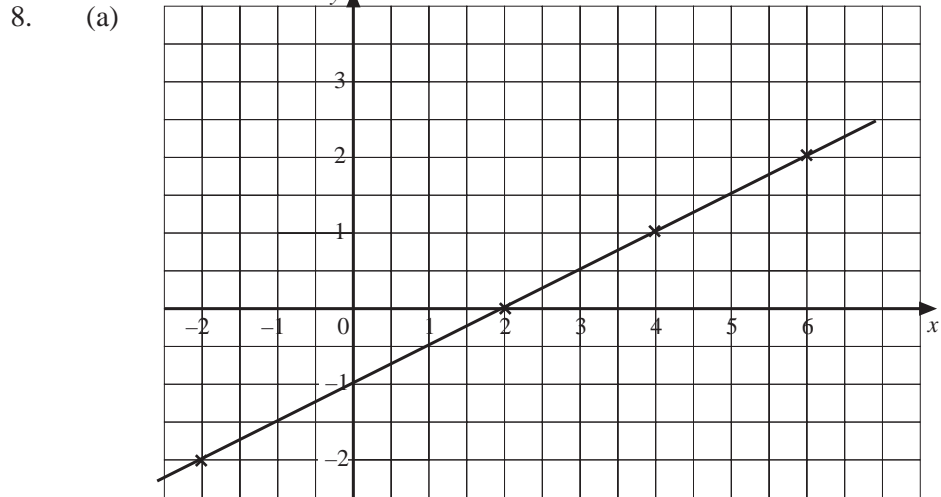

(b) $y = \frac{1}{2}x - 1$

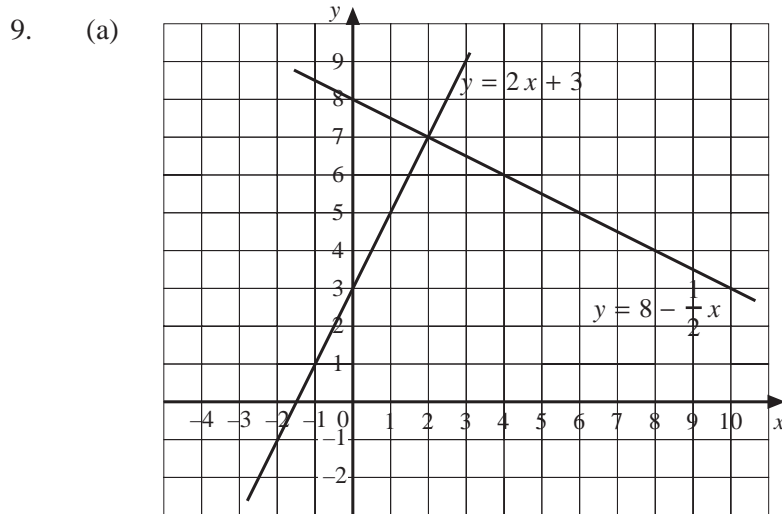

(b) The lines cross at (2, 7).

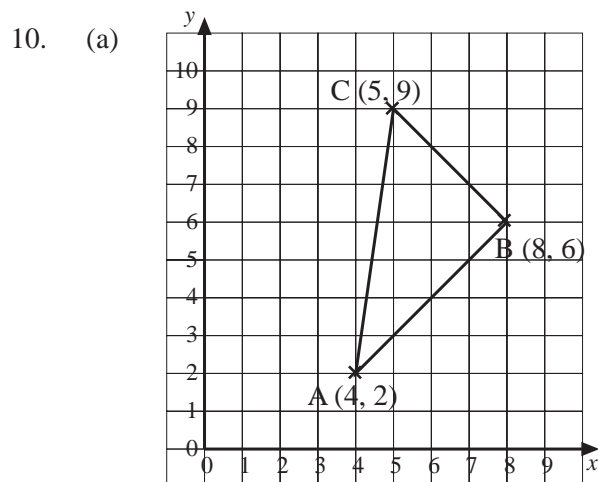

- (b) A B has equation $y = x - 2$
 B C has equation $y = 14 - x$
 A C has equation $y = 7x - 26$

5.2

Answers

11. (a) $x = 8$ (b) $y = x + 7$ (c) $y = x - 1$
12. (a) 5 squares with 4 pins in each square
7 squares with 3 pins in each square
- (b) The gradient 3 tells you how steep the line $p = 3s + 1$ is.
- (c) Any three points on the line $p = 7s + 1$, e.g. (1, 8), (2, 15) and (3, 22)
- (d) $p = 7s + 1$

5.3 Linear Equations

1. (a) $x = 8$ (b) $x = 11$ (c) $x = 3$ (d) $x = 30$
 (e) $x = 8$ (f) $x = 7$ (g) $x = 13$ (h) $x = 7$
 (i) $x = 40$ (j) $x = 500$ (k) $x = 32$ (l) $x = 25$
2. (a) $x = 4$ (b) $x = 7$ (c) $x = 3$ (d) $x = 2$
 (e) $x = 7$ (f) $x = 59$ (g) $x = 8$ (h) $x = 5$
 (i) $x = 11$ (j) $x = 10$ (k) $x = 3$ (l) $x = 2$
3. (a) $x = 2$ (b) $x = 5$ (c) $x = 4$ (d) $x = 3$
 (e) $x = 5$ (f) $x = 4$ (g) $x = 2\frac{1}{2}$ (h) $x = 4\frac{1}{2}$
4. (a) $x = 3$ (b) $x = 6$ (c) $x = 4$

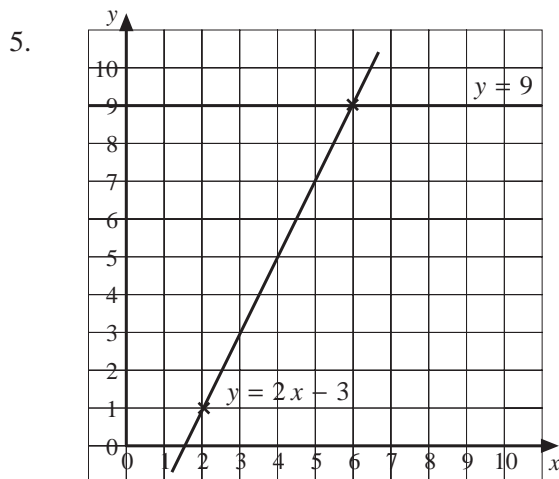

The solution is $x = 6$.

5.3

Answers

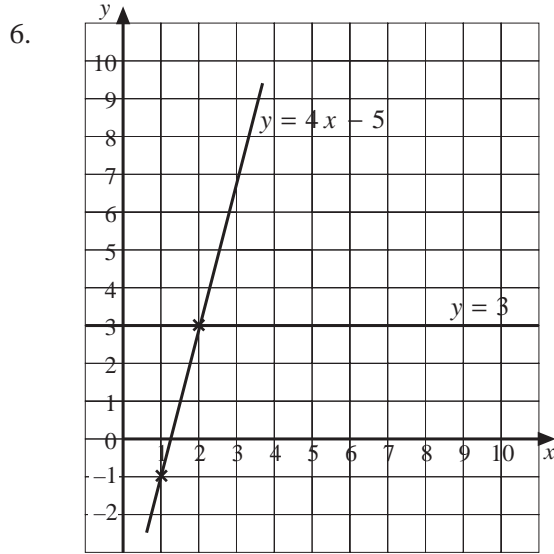

The solution is $x = 2$.

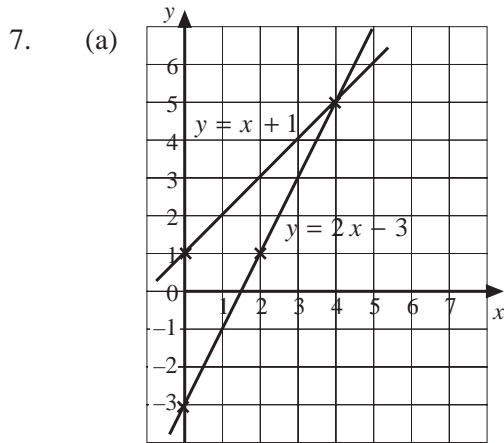

(b) The solution is $x = 4$.

8. (a) $x = 1$ (see graph opposite)

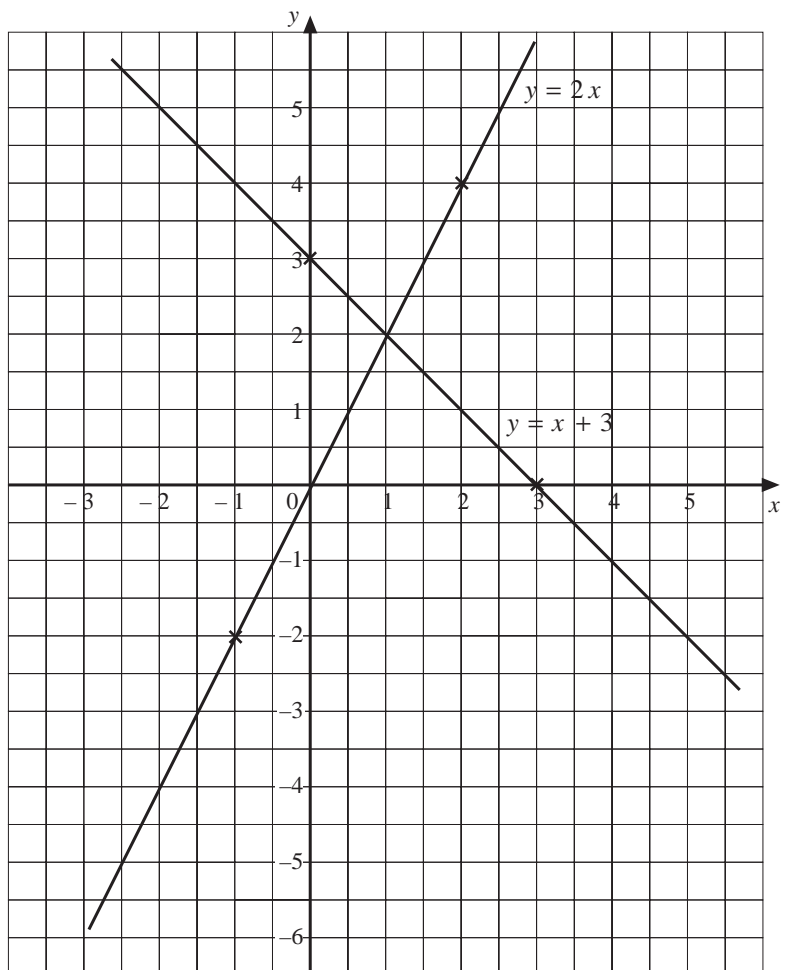

5.3

Answers

8. (b) $x = 3$ (see graph opposite)

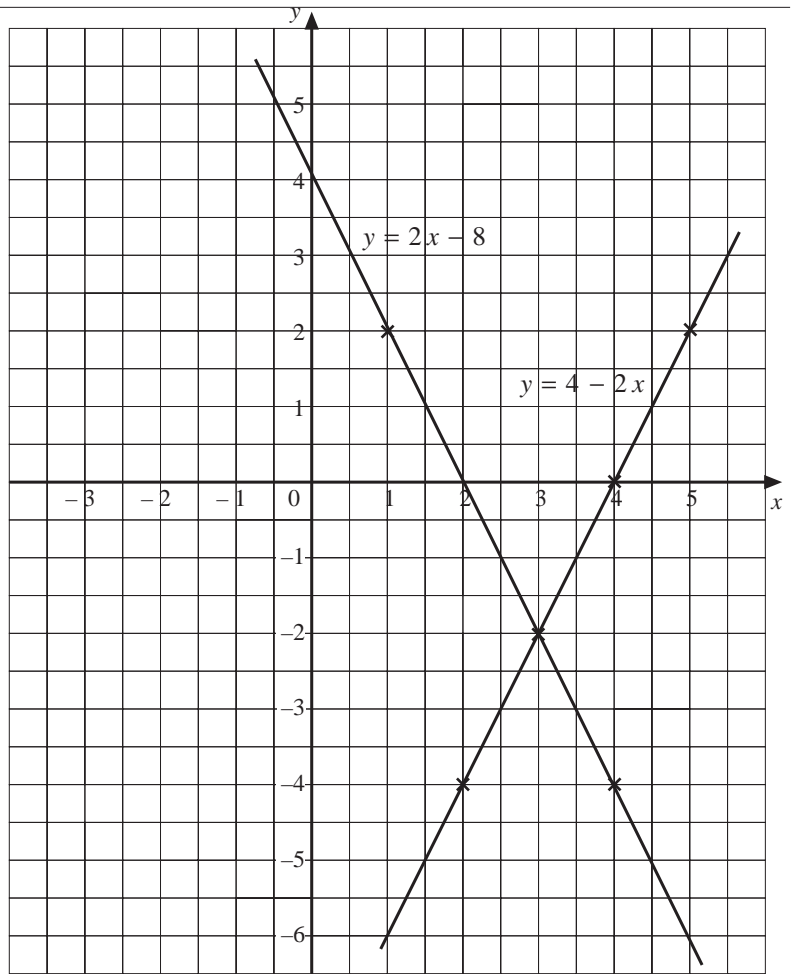

9. (a) $x = 3$
 (b) $x = 4$
 (c) $x = 1$

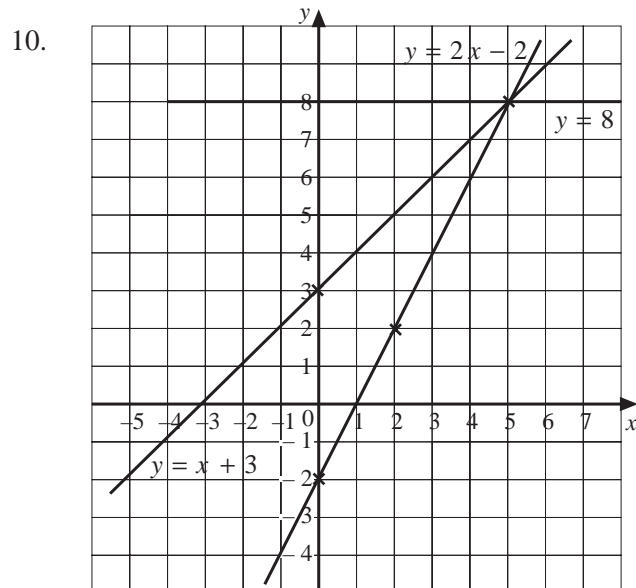

- (a) $x = 5$
 (b) $x = 5$
 (c) $x = 5$

11. (a) $y = 1\frac{1}{2}$ (b) $y = -16$

5.4

Answers

5.4 Parallel and Perpendicular Lines

1. (a)

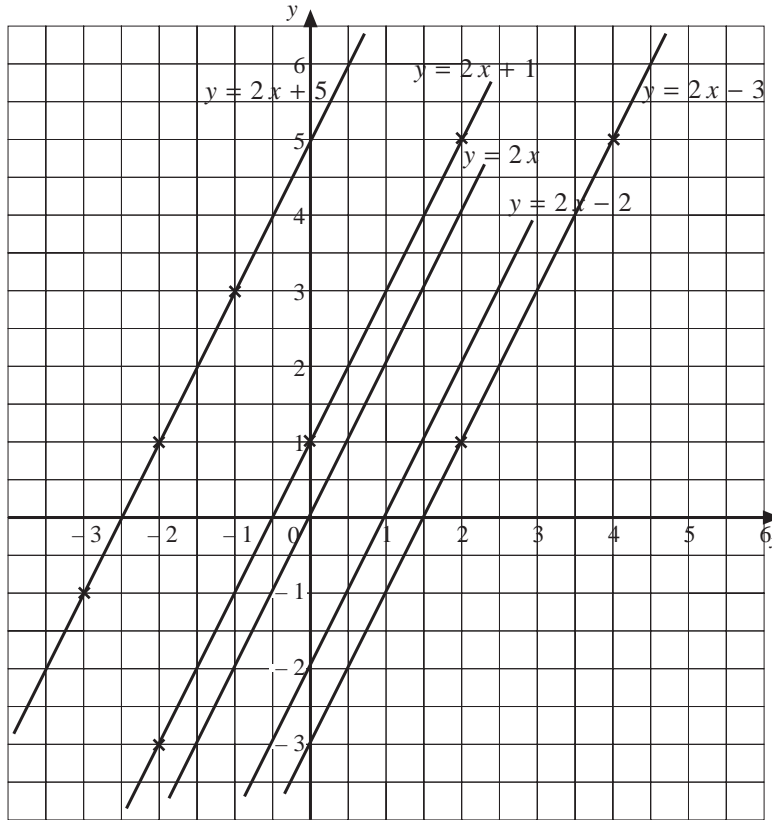

(b) Any two lines of the form $y = 2x + c$, with c not equal to 5, 1 or -3 . In this case, the diagram shows the lines $y = 2x$ and $y = 2x - 2$.

2. (a) and (b)

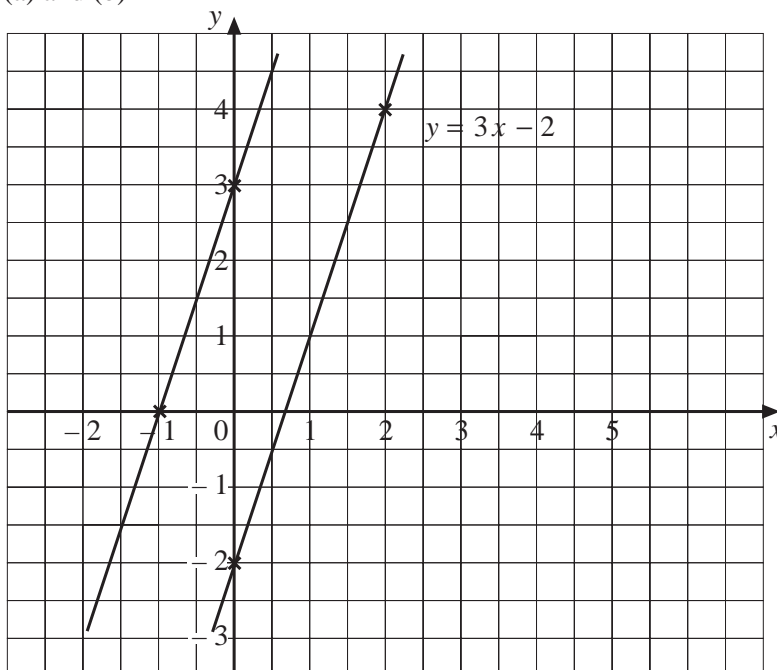

(c) The second line has equation $y = 3x + 3$.

5.4

Answers

3. (a) E (b) D
 (c) There are no lines parallel to B because B has gradient 2 whilst A and E have gradient 5, and C and D have gradient 3.
4. (a) 3 (b) $y = 3x$ (c) $y = 3x - 3$
5. (a) $y = -\frac{1}{4}x + 4$ (b) $y = -\frac{1}{4}x$ (c) $y = -\frac{1}{4}x - 2$
6. (a) $-\frac{2}{3}$ (b) $y = -\frac{2}{3}x + 10$ (c) $y = -\frac{2}{3}x + 6$
7. (a) $\frac{1}{3}$ (b) -3
 (c) The lines are perpendicular because $-3 \times \frac{1}{3} = -1$ and the product of the gradient is -1 for perpendicular lines.
8. (a) D (b) E (c) C
9. (a) Gradient of A = 3
 B = $-\frac{1}{3}$
 C = $-\frac{4}{5}$
- (b) Lines A and B are perpendicular.
10. (a) Any two lines of the form $y = 4x + c$, with $c \neq 3$, e.g. $y = 4x + 10$ and $y = 4x + 8$
 (b) Any two lines of the form $y = -\frac{1}{4}x + c$, e.g. $y = -\frac{1}{4}x + 4$ and $y = -\frac{1}{4}x - 7$

11. (a) and (c)

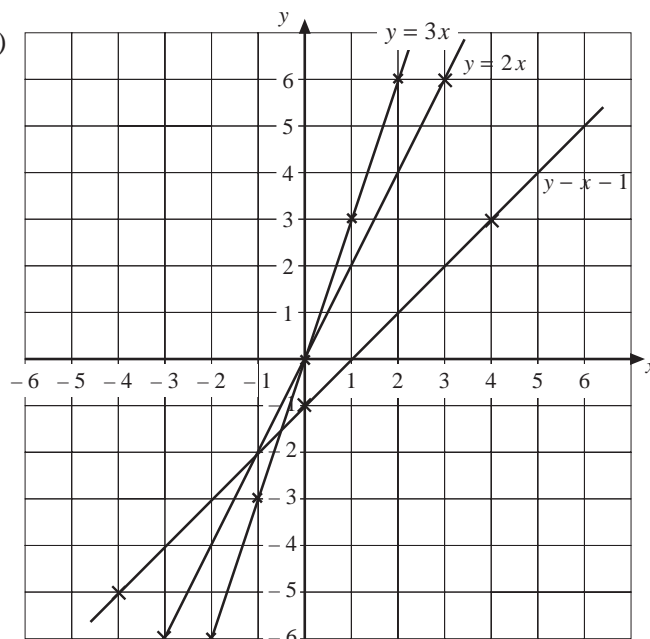

- (b) Any equation of the form $y = mx$ where $m \neq 2$ or 3 .

- (d) $y = 3x - 1$

5.4

Answers

12. (a) That they are parallel, with gradient $= \frac{1}{2}$.
 (b) The constant term gives the intercept, i.e the value where the line crosses the y-axis.
 (c) $(0, -20)$
 (d) Any line of the form $y = \frac{1}{2}x + c$, where $c \neq 4, 0, -3$ or -20 .

5.5 Simultaneous Equations

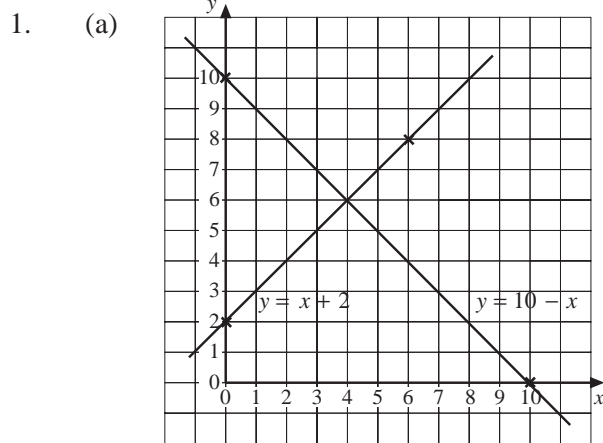

- (b) Intersection $(4, 6)$
 (c) $x = 4, y = 6$

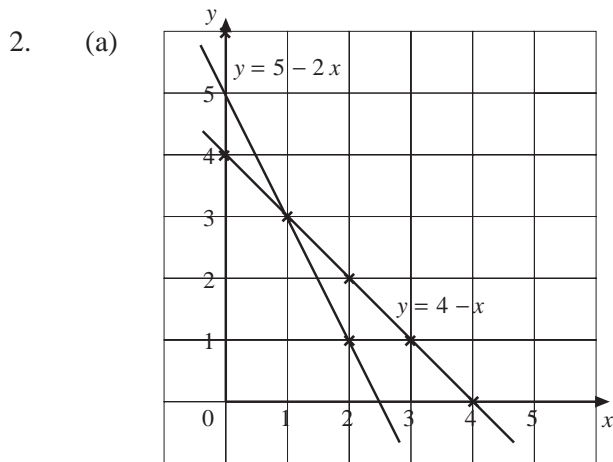

- (b) Intersection $(1, 3)$
 (c) $x = 1, y = 3$

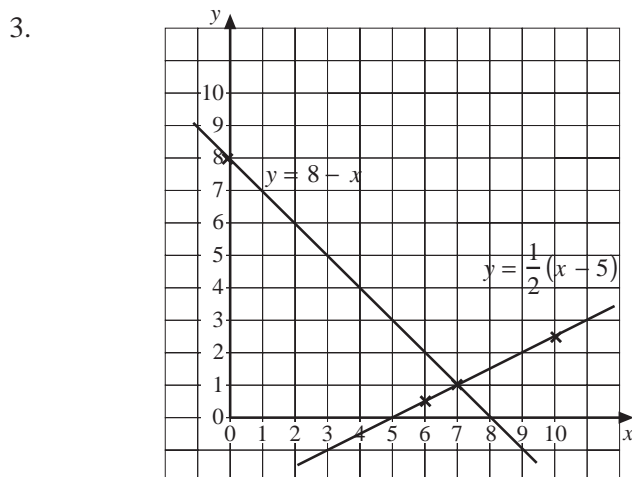

The solution is $x = 7, y = 1$.

5.5

Answers

4.

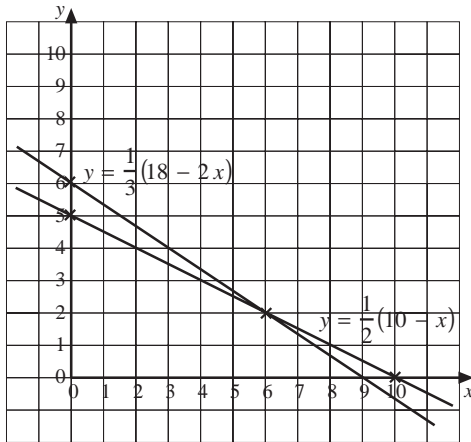

The solution is $x = 6, y = 2$.

5. (a) $x + y = 24$
 $x - y = 6$

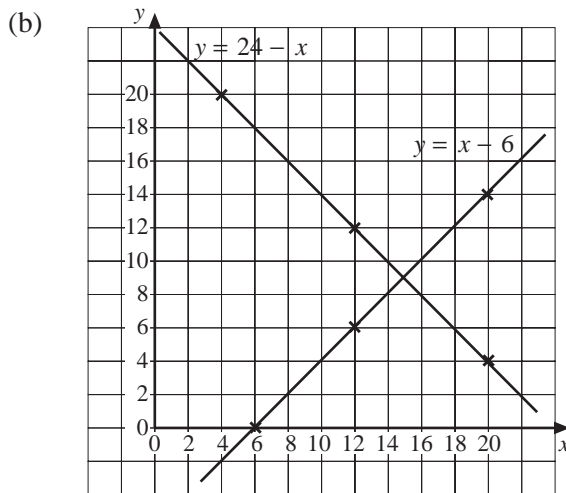

The solutions to the simultaneous equations are $x = 15, y = 9$, so the numbers are 15 and 9.

6. $x + 2y = 8$ and $2x + y = 10$

7. (a) Because it eliminates the unknown x , leaving an equation in y only.

(b) $3y = 6$
 $y = 2, x = 3$

8. (a) $x = 3, y = 1$ (b) $x = 5, y = 2$ (c) $x = 7, y = 2$
 (d) $x = 11, y = -4$ (e) $x = 9, y = 3$ (f) $x = 10, y = 3$

9. (a) Because it eliminates x , leaving an equation in y only. (b) $x = 11, y = 1$

10. (a) $x = 1, y = 3$ (b) $x = 5, y = 3$ (c) $x = 5, y = 1$
 (d) $x = 7, y = 1$ (e) $x = 20, y = 2$ (f) $x = 7, y = 2$

5.5

Answers

11. (a) Line A has gradient (for example) $\frac{-8}{4} = -2$ and it has intercept 8, so the equation is $y = -2x + 8$, i.e. $2x + y = 8$.

(b) $x = 8 - x$ or $x + y = 8$

(d) Any suitable method leading to $x = 1\frac{1}{2}$, $y = 4$.

12. (a) $y = -10$

(b) ... the line through A and B.

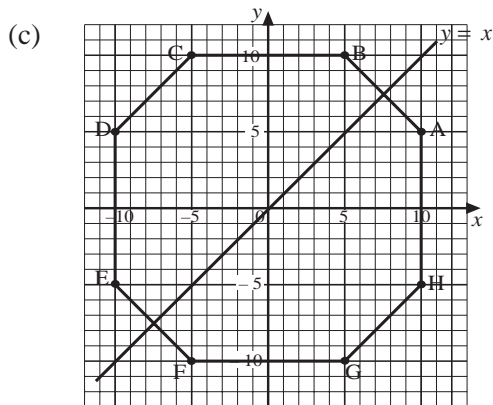

(d) One of: $y = -x$
 $x = 0$
 $y = 0$

(e) Any suitable method to obtain $x = 35$, $y = 20$.

(f) ... G and H at $(35, 20)$.

(c)

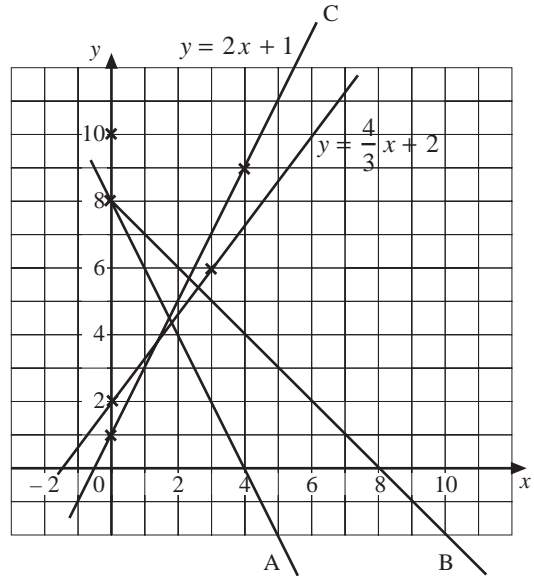

5.6 Equations in Context

1. (a) $\pounds 9n$ (b) $n = 12$

2. (a) $c = 0.5m + 20$ (b) $c = 0.5m + 40$

(c) $68.50 = 0.5m + 40$ $m = 57$ miles

3. $x + (x + 2) = 100$, i.e. $2x + 2 = 100$, giving $x = 49$

4. $25 + 4m = 39$ Distance travelled was 3.5 miles.

5. (a) $\pounds 3.60$ (b) $\pounds 0.045x$ per gallon (c) 92 pence per litre

5.6

Answers

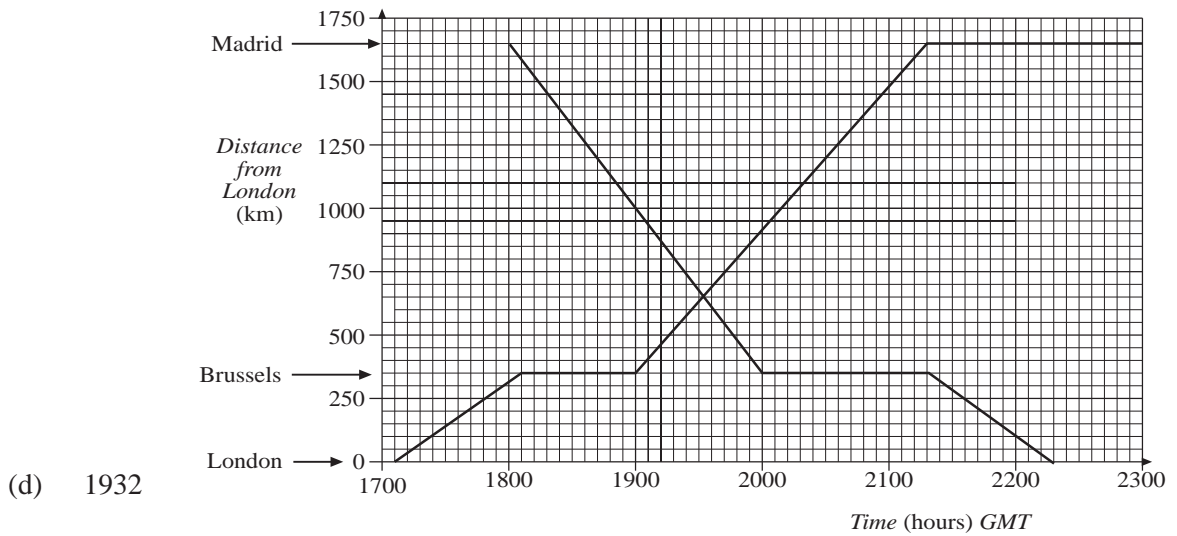

6. (a) Area = $10x \text{ m}^2$ (b) $10x = 16$, giving $x = 1.6$
 (c) Perimeter = $(2x + 20) \text{ m}$ (d) $2x + 20 = 39$, giving $x = 9.5 \text{ m}$
7. (a) Cost = $\pounds(15n + 25)$
 (b) $15n + 25 = 52.5$, giving $n = 1\frac{5}{6}$ hours, i.e. the repair took 1 hour 50 minutes
8. (a) Number of Fr = $9(x - 2)$
 (b) $9x(x - 2) = 900$, giving $x = 102$, i.e. you need $\pounds102$ to get 900 Fr.
9. (a) Perimeter = $12x$ (b) $x = 23 \text{ m}$ (c) Area = $6x^2$ (d) $x = 1.2 \text{ m}$
10. (a) Perimeter = $(20 + 2x) \text{ m}$ (b) $x = 1.5 \text{ m}$
11. (a) 350 km per hour
 (b) Because the third section (Brussels to Madrid) has a steeper gradient than the first section (London to Brussels).
 (c)



Practice Book *UNIT 6 Probability*

Answers

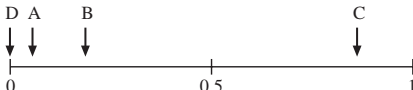
6.1 The Probability Scale

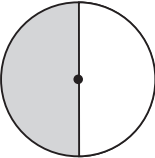
- Pupils' individual descriptions. It is best to discuss these with the whole class.
- This depends on the year and the political climate.
 - Not reasonable – this estimate is far too high.
 - Reasonable, if in a dry spell; not reasonable if in a wet spell.
 - Not reasonable – the probability of the school being hit by lightning is *very* remote.
- Answers here will depend on the pupil concerned. It may be best to invite individual students to present their order and scale to the rest of the class.
- Because it is impossible to be the first person to walk on the moon as Neil Armstrong did that in 1969.
- Pupils' individual descriptions. It is best to discuss these with the whole class.
- No
 - Assuming that there are aliens, there is a very small chance of being abducted, so the probability will be very close to 1, but not equal to 1.
- Pupils' individual descriptions. It is best to discuss these with the whole class.
- Pupils' individual descriptions. It is best to discuss these with the whole class. Suggestions might include getting an even number when you throw a fair dice or a rat turning right in a maze when presented with a left/right choice at a T-junction.
- C, B, A, D
 
- A, because the probability 0.1 implies that the train is late only once in every 10 occasions.
- Joe is wrong because there is an equal number of squares and triangles, so both have a probability of $\frac{1}{2}$.
 "It is certain that the number on Sara's card will be smaller than 10."
 "It is likely that the number on Sara's card will be an odd number."
 - "On the next card, \triangle is more likely than \blacksquare ."
or "On the next card an even number is less likely than an odd number."
 Higher than 5 is more likely, because the remaining cards have the number 2, 3, 4, 7, 8, 9, and 9, i.e. there are 4 numbers above 5 and only 3 numbers below 5."
- S
 - R (zero probability)
 - 
 - 
- D
 - B
 - E
 - C
 - A
 - 6 or more
 - 10 black and 10 white

6.2

Answers

6.2 The Probability of a Single Event

1. (a) $\frac{1}{6}$ (b) $\frac{1}{6}$ (c) $\frac{1}{2}$ (d) $\frac{1}{3}$ (e) $\frac{5}{6}$
2. (a) $\frac{3}{10}$ (b) $\frac{7}{10}$ (c) 0 (do *not* allow $\frac{0}{30}$ or $\frac{0}{10}$)
3. (a) $\frac{1}{26}$ (b) $\frac{2}{13}$ (c) $\frac{3}{13}$ (d) $\frac{1}{4}$ (e) $\frac{3}{4}$
4. (a) $\frac{1}{4}$ (b) $\frac{1}{3}$ (c) $\frac{5}{12}$ (d) $\frac{2}{3}$ (e) $\frac{3}{4}$
5. (a) $\frac{1}{4}$ (b) $\frac{1}{4}$ (c) $\frac{3}{4}$ (d) $\frac{1}{2}$
6. (a) $\frac{1}{2}$ (b) $\frac{1}{4}$ (c) $\frac{1}{8}$ (d) $\frac{1}{8}$
 (e) 0 (do *not* allow $\frac{0}{8}$) (f) 1 (do *not* allow $\frac{8}{8}$)
7. (a) 180
 (b) No - the number of trials is not really large enough to have the probability settle down.
8. (a) 2 (b) 50 (c) 80
9. (a) 20 (b) 10 (c) 130 (d) 65 (e) 100
10. (a) 90 (b) 150 (c) 60 (d) 30
11. (a) $\frac{56}{200} = 0.28$ (b) $0.28 \times 1200 = 336$
12. (a) ATLN, ATNL, LTNA, LTAN, NTAL, NTLA (b) $\frac{7}{8}$
13. (a) $\frac{1}{2}$ (b) Any 8 sectors shaded. (c) Any 8 sectors shaded.
14. (a) Maria is correct. Owen is wrong because the selection is 1 black from a total of 6 in the bag.
 (b) $\frac{6}{13}$
 (c) $7n$ black beads and $6n$ white beads (for any positive integer n), e.g. 7B, 6W or 14B, 12W.
 (d) $7m$ black beads and $6m$ white beads (for any positive integer m greater than the n given in part (c), e.g. 30W and 35 B.

6.2

Answers

15. (a) 0.88 (b) 0.08 (c)

16. (a) $\frac{3}{5}$ (b) 1

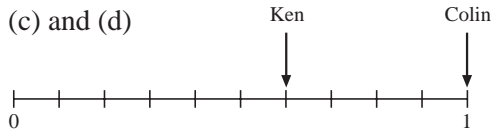

| <i>Time</i> | <i>Failed</i> | <i>Still working</i> |
|---------------|---------------|----------------------|
| At 1000 hours | 0.07 | 0.93 |
| At 2000 hours | 0.57 | 0.43 |

(e) Mandy likes only 2 out of the 5 sweets (or any equivalent comment, e.g. there are 3 sweets that she does not like).

6.3 The Probability of Two Events

1. (a) RR, RB, RY, BR, BB, BY, YR, YB, YY

(b) (i) $\frac{1}{9}$ (ii) $\frac{1}{3}$ (iii) $\frac{2}{3}$

2. (a) AA, AB, AC, AD, BA, BB, BC, BD, CA, CB, CC, CD, DA, DB, DC, DD

(b) (i) $\frac{1}{16}$ (ii) $\frac{7}{16}$ (iii) $\frac{1}{4}$ (iv) $\frac{9}{16}$

3. (a) *First Dice*

| | | | | | | | |
|--------------------|---|---|---|---|---|----|----|
| | | 1 | 1 | 2 | 3 | 4 | 6 |
| <i>Second Dice</i> | 1 | 2 | 2 | 3 | 4 | 5 | 7 |
| | 1 | 2 | 2 | 3 | 4 | 5 | 7 |
| | 2 | 3 | 3 | 4 | 5 | 6 | 8 |
| | 3 | 4 | 4 | 5 | 6 | 7 | 9 |
| | 4 | 5 | 5 | 6 | 7 | 8 | 10 |
| | 6 | 7 | 7 | 8 | 9 | 10 | 12 |

(b) (i) $\frac{1}{12}$ (ii) $\frac{1}{9}$
 (iii) $\frac{1}{36}$ (iv) $\frac{13}{36}$

4. (a) *Blue Spinner*

| | | | | | | |
|--------------------|---|---|---|---|---|---|
| | | 1 | 2 | 3 | 4 | 5 |
| <i>Red Spinner</i> | 1 | 2 | 3 | 4 | 5 | 6 |
| | 2 | 3 | 4 | 5 | 6 | 7 |
| | 3 | 4 | 5 | 6 | 7 | 8 |
| | 4 | 5 | 6 | 7 | 8 | 9 |

(b) (i) $\frac{1}{2}$ (ii) $\frac{3}{20}$
 (iii) $\frac{7}{10}$ (iv) $\frac{7}{10}$

5. (a) *Dice*

| | | | | | | | |
|-------------|---|----|----|----|----|----|----|
| | | 1 | 2 | 3 | 4 | 5 | 6 |
| <i>Coin</i> | H | H1 | H2 | H3 | H4 | H5 | H6 |
| | T | T1 | T2 | T3 | T4 | T5 | T6 |

(b) (i) $\frac{1}{12}$ (ii) $\frac{1}{4}$
 (iii) $\frac{1}{3}$

6.3

Answers

6. (a) *1st Toss* *2nd Toss* *PROBABILITIES*

| | | | | | | | | | |
|---------------|---|---------------|---|---|-----|-----|----------------|------|-----------------|
| $\frac{3}{5}$ | H | $\frac{3}{5}$ | H | $\frac{3}{5} \times \frac{3}{5} = \frac{9}{25}$ | (b) | (i) | $\frac{9}{25}$ | (ii) | $\frac{21}{25}$ |
| | | $\frac{2}{5}$ | T | $\frac{3}{5} \times \frac{2}{5} = \frac{6}{25}$ | | | | | |
| $\frac{2}{5}$ | T | $\frac{3}{5}$ | H | $\frac{2}{5} \times \frac{3}{5} = \frac{6}{25}$ | | | | | |
| | | $\frac{2}{5}$ | T | $\frac{2}{5} \times \frac{2}{5} = \frac{4}{25}$ | | | | | |

7. (a) P = Prize, N = No Prize

1st Roll *2nd Roll* *PROBABILITIES*

| | | | | | | | | | |
|---------------|---|---------------|---|--|-----|-----|---------------|------|---------------|
| $\frac{1}{3}$ | P | $\frac{1}{3}$ | P | $\frac{1}{3} \times \frac{1}{3} = \frac{1}{9}$ | (b) | (i) | $\frac{1}{9}$ | (ii) | $\frac{4}{9}$ |
| | | $\frac{2}{3}$ | N | $\frac{1}{3} \times \frac{2}{3} = \frac{2}{9}$ | | | | | |
| $\frac{2}{3}$ | N | $\frac{1}{3}$ | P | $\frac{2}{3} \times \frac{1}{3} = \frac{2}{9}$ | | | | | |
| | | $\frac{2}{3}$ | N | $\frac{2}{3} \times \frac{2}{3} = \frac{4}{9}$ | | | | | |

8. R = Royal, N = Not Royal

1st Card *2nd Card* *PROBABILITIES*

| | | | | | | | | |
|-----------------|---|-----------------|---|--|-----|-----------------|-----|------------------|
| $\frac{3}{13}$ | R | $\frac{3}{13}$ | R | $\frac{3}{13} \times \frac{3}{13} = \frac{9}{169}$ | (a) | $\frac{9}{169}$ | (b) | $\frac{60}{169}$ |
| | | $\frac{10}{13}$ | N | $\frac{3}{13} \times \frac{10}{13} = \frac{30}{169}$ | | | | |
| $\frac{10}{13}$ | N | $\frac{3}{13}$ | R | $\frac{10}{13} \times \frac{3}{13} = \frac{30}{169}$ | | | | |
| | | $\frac{10}{13}$ | N | $\frac{10}{13} \times \frac{10}{13} = \frac{100}{169}$ | | | | |

(c) $\frac{69}{169}$ (d) $\frac{100}{169}$

6.3

Answers

9. L = Late, N = Not Late

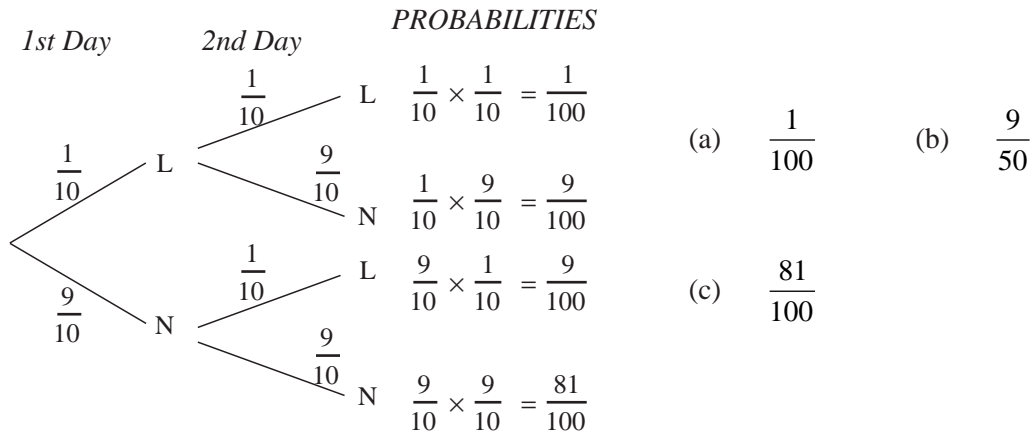

10. (a) B = Burnt, N = Not Burnt

$p(\text{at least one slice burnt}) = \frac{17}{81}$
 (see tree diagram opposite)

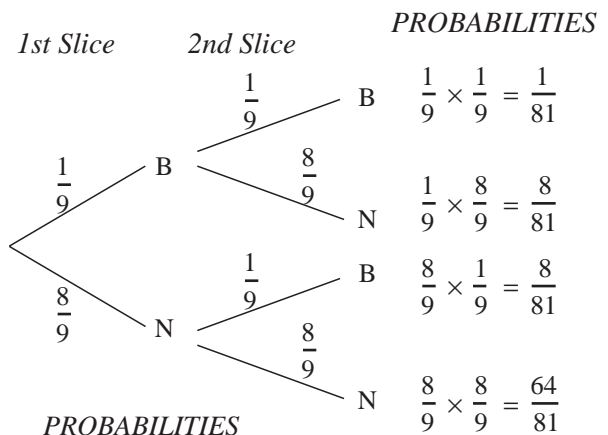

(b) $p(\text{at least one slice burnt}) = \frac{217}{729}$
 (see tree diagram below)

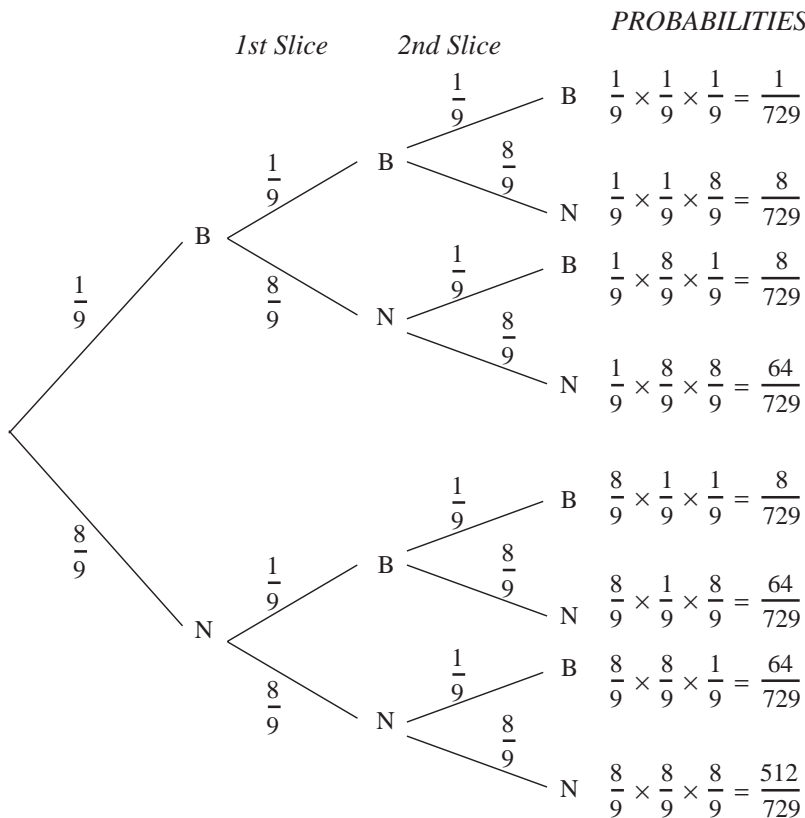

6.3

Answers

11. (a) $\frac{1}{2}$ (b)

| First coin | Second coin |
|------------|-------------|
| heads | heads |
| heads | tails |
| tails | heads |
| tails | tails |

 (c) $\frac{1}{4}$ (d) $\frac{1}{2}$

12. (a) $\frac{35}{36}$

(b) $\frac{1}{36}$

(c) $\frac{1}{36}$

(d) $\frac{1}{6}$

13. (a) (i) $0.7 \times 0.7 = 0.49$ (ii) $(0.7 \times 0.3) + (0.3 \times 0.7) = 0.42$

(b) $p(\text{drives through both sets of lights without stopping}) = 0.3 \times 0.3 = 0.09$,
so the estimated number of times he goes through unstopped = $200 \times 0.09 = 18$.

14. (a) $\frac{69}{100}$ or 0.69 or 69% (b) $\frac{27}{57} = \frac{9}{19}$ (c) $\frac{27}{100} \times \frac{26}{100}$

15. (a) 0.000625 (b) 0.04875 (c) 120

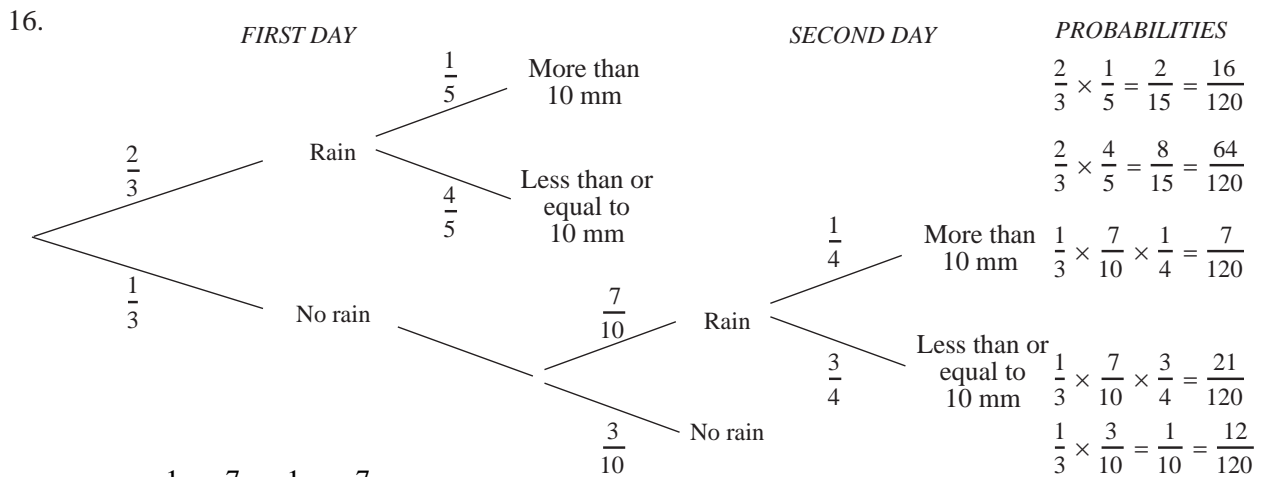

(a) $\frac{1}{3} \times \frac{7}{10} \times \frac{1}{4} = \frac{7}{120}$

(b) $\frac{2}{3} + \left(\frac{1}{3} \times \frac{7}{10}\right) = \frac{20}{30} + \frac{7}{30} = \frac{27}{30} = \frac{9}{10}$

(c) Because we are not given the probability that it rains in the second day if it rains on the first.

17. (a) $(0.6 \times 0.8) + (0.4 \times 0.55) = 0.7$ (b) $(0.6 \times 0.2) + (0.4 \times 0.55) = 0.34$

(c) $(0.6 \times 0.8 \times 0.1) + (0.6 \times 0.2 \times 0.9) + (0.4 \times 0.55 \times 0.9) = 0.354$

(d) $(0.6 \times 0.2 \times 0.1) + (0.4 \times 0.55 \times 0.1) + (0.4 \times 0.45 \times 0.9) = 0.196$

6.4

Answers

6.4 Theoretical and Experimental Probabilities

1. (a) 50 head and 50 tails (b) and (c) Pupils' own results, bar charts and comparisons.

2. (a) (i) $\frac{1}{4}$ (ii) $\frac{1}{2}$ (iii) $\frac{1}{4}$

(b) 2 heads - 25 times; 1 head and 1 tail - 50 times; 2 tails - 25 times

(c) and (d) Pupils' own results and comparisons

3. (a) HHH, HHT, HTH, THH, TTH, THT, HTT, TTT

(b) (i) 4 (ii) 12 (iii) 12 (iv) 4

4. (a)

| | | | | | | | | | | | |
|---------------------------|---|---|---|---|---|---|---|---|----|----|----|
| <i>Total</i> | 2 | 3 | 4 | 5 | 6 | 7 | 8 | 9 | 10 | 11 | 12 |
| <i>Expected Frequency</i> | 1 | 2 | 3 | 4 | 5 | 6 | 5 | 4 | 3 | 2 | 1 |

(b) Pupils' own results and comparisons

(c)

| | | | | | | | | | | | |
|---------------------------|---|---|----|----|----|----|----|----|----|----|----|
| <i>Total</i> | 2 | 3 | 4 | 5 | 6 | 7 | 8 | 9 | 10 | 11 | 12 |
| <i>Expected Frequency</i> | 4 | 8 | 12 | 16 | 20 | 24 | 20 | 16 | 12 | 8 | 4 |

(d) The results in (c) from 144 throws should be closer to the predictions than the results in (b) from 72 throws.

5. (a) *Dice*

| | | | | | | | |
|-------------|--------------|---|---|---|---|----|----|
| | | 1 | 2 | 3 | 4 | 5 | 6 |
| <i>Coin</i> | <i>Heads</i> | 2 | 4 | 6 | 8 | 10 | 12 |
| | <i>Tails</i> | 0 | 1 | 2 | 3 | 4 | 5 |

(b)

| | | | | | | | | | | |
|--------------------------------|----------------|----------------|---------------|----------------|---------------|----------------|----------------|----------------|----------------|----------------|
| <i>Total</i> | 0 | 1 | 2 | 3 | 4 | 5 | 6 | 8 | 10 | 12 |
| <i>Theoretical Probability</i> | $\frac{1}{12}$ | $\frac{1}{12}$ | $\frac{1}{6}$ | $\frac{1}{12}$ | $\frac{1}{6}$ | $\frac{1}{12}$ | $\frac{1}{12}$ | $\frac{1}{12}$ | $\frac{1}{12}$ | $\frac{1}{12}$ |

(c)

| | | | | | | | | | | |
|---------------------------|----|----|----|----|----|----|----|----|----|----|
| <i>Total</i> | 0 | 1 | 2 | 3 | 4 | 5 | 6 | 8 | 10 | 12 |
| <i>Expected Frequency</i> | 10 | 10 | 20 | 10 | 20 | 10 | 10 | 10 | 10 | 10 |

(d) Pupils' own results and comparisons

6.4

Answers

6. (a) Shana: greater number of trials leads to better results.
 (b) The data does indicate that the dice is biased. If it was unbiased, we would expect to get frequencies of approximately 130 for each colour. However, the frequencies for red and blue are well above 130 and the frequencies for green and yellow are well below 130, which is fairly strong evidence that the dice is biased.

(c) $p(B) = \frac{186}{520} = \frac{93}{260} = 0.358$ (to 3 d.p.) (d) $p(G) = \frac{75}{520} = \frac{15}{104} = 0.144$ (to 3 d.p.)

7. (a) Sue, because she conducted the experiment the greatest number of times.

(b) $\frac{171}{300} = \frac{57}{100} = 0.57$

- (c)

| <i>Number of throws</i> | <i>Results</i> | | |
|-----------------------------|--|-------------------|--------------------------------------|
| | <i>all different</i> | <i>2 the same</i> | <i>all the same</i> |
| 300 | $166\frac{2}{3}$ i.e. about 167 times | 125 | $8\frac{1}{3}$ i.e. about 8 times |

- (d) There are insufficient trials for really accurate comparison.
 (The pupils' results are close to the theoretical results, i.e. they are within the margin of experimental error. In this case, it would be impossible to get the theoretical results exactly because the values are not all integers. Even if they were integers, we would still not expect to match the predicted results exactly because of experimental variation. The discrepancy between the predicted and experimental results should close as the experiment is conducted more often beyond the present 300 times.)

Practice Book *UNIT 7 Transformations*

Answers

7.1 Shapes

1. (a) Rectangle or square (b) Trapezium (c) Square, rhombus or kite

2. (a) C and H (b) B, C, H and I

| 3. | <u>Length (cm)</u> | <u>Width (cm)</u> | <u>Area (cm²)</u> | <u>Length (cm)</u> | <u>Width (cm)</u> | <u>Area (cm²)</u> |
|----|--------------------|-------------------|------------------------------|--------------------|-------------------|------------------------------|
| | 1 | 19 | 19 | 9 | 11 | 99 |
| | 2 | 18 | 36 | 9.1 | 10.9 | 99.19 |
| | 3 | 17 | 51 | 9.2 | 10.8 | 99.36 |
| | 4 | 16 | 64 | 9.3 | 10.7 | 99.51 |
| | 5 | 15 | 75 | 9.4 | 10.6 | 99.64 |
| | 6 | 14 | 84 | 9.5 | 10.5 | 99.75 |
| | 7 | 13 | 91 | 9.6 | 10.4 | 99.84 |
| | 8 | 12 | 96 | 9.7 | 10.3 | 99.91 |
| | 9 | 11 | 99 | 9.8 | 10.2 | 99.96 |
| | 10 | 10 | 100 | 9.9 | 10.1 | 99.99 |
| | | | | 10 | 10 | 100 |

The first table gives the integer possibilities, but pupils should be encouraged to justify the correct maximum area by looking at rectangles close in size to a square of side 10 cm, as in the second table.

The shape that gives the maximum area is a square of side 10 cm.

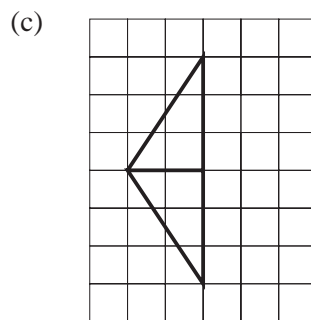
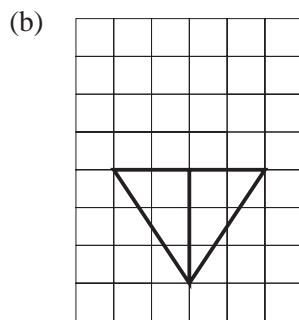
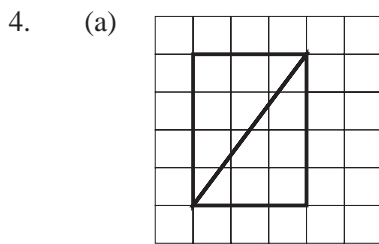

N.B. The answers for parts (b) and (c) are interchangeable.



(d) Any suitable combination of 9, 16, 25, 36, ... triangles to make a larger triangle, e.g.

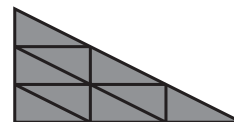

7.1

Answers

6. (a)

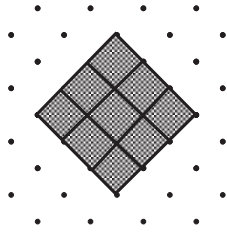

(b) A suitable combination of 16, 25, 36, ... square tiles. In the case illustrated, there are 36 tiles:

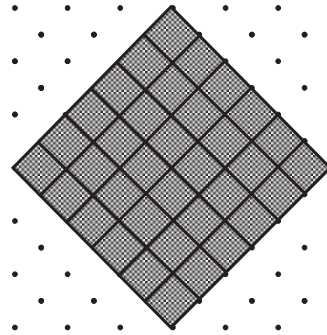

(c) Any three square numbers from the list 16, 25, 36, 49, 64, 81, 100, ... excluding the number of tiles given as the answer to part (b).

7. (a) There are two possible combinations using the rods 5, 5, 7 and 4 + 3 or 5, 5, 6, and 4 + 2.

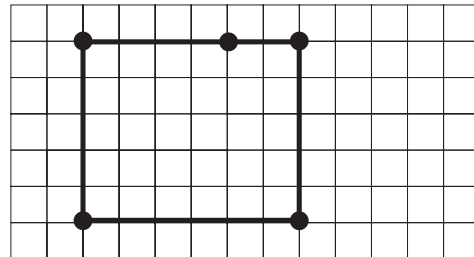
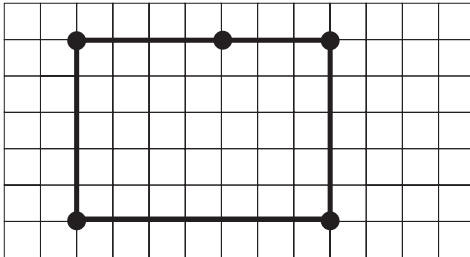

(c) The possible solutions are given in the following table:

| <i>Rods Used</i> | | | | <i>Rectangle Size</i> |
|------------------|-------|-------|-------|-----------------------|
| 5 | 5 | 8 + 3 | 7 + 4 | 5 × 11 |
| 5 | 5 | 8 + 2 | 7 + 3 | 5 × 10 |
| 5 | 5 | 8 + 2 | 6 + 4 | 5 × 10 |
| 5 | 5 | 7 + 3 | 6 + 4 | 5 × 10 |
| 5 | 5 | 7 + 2 | 6 + 3 | 5 × 9 |
| 8 | 6 + 2 | 7 | 4 + 3 | 8 × 7 |
| 8 | 5 + 3 | 7 | 5 + 2 | 8 × 7 |
| 8 | 5 + 3 | 6 | 4 + 2 | 8 × 6 |

(d) The total length of all the rods is 40 cm so the square must have sides of length 10 cm. There is only one combination here:

$$5 + 5, 6 + 4, 7 + 3 \text{ and } 8 + 2$$

7.2

Answers

7.2 Translations

1. (a) and (b)

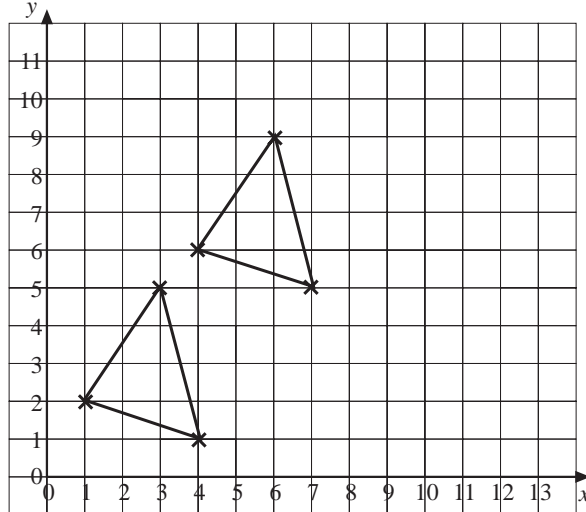

(c) (7, 5), (6, 9), (4, 6)

2. (a) $\begin{pmatrix} 0 \\ 6 \end{pmatrix}$ (b) $\begin{pmatrix} 11 \\ 0 \end{pmatrix}$ (c) $\begin{pmatrix} 6 \\ 7 \end{pmatrix}$ (d) $\begin{pmatrix} 9 \\ 4 \end{pmatrix}$ (e) $\begin{pmatrix} 6 \\ 1 \end{pmatrix}$

3. (a) and (b)

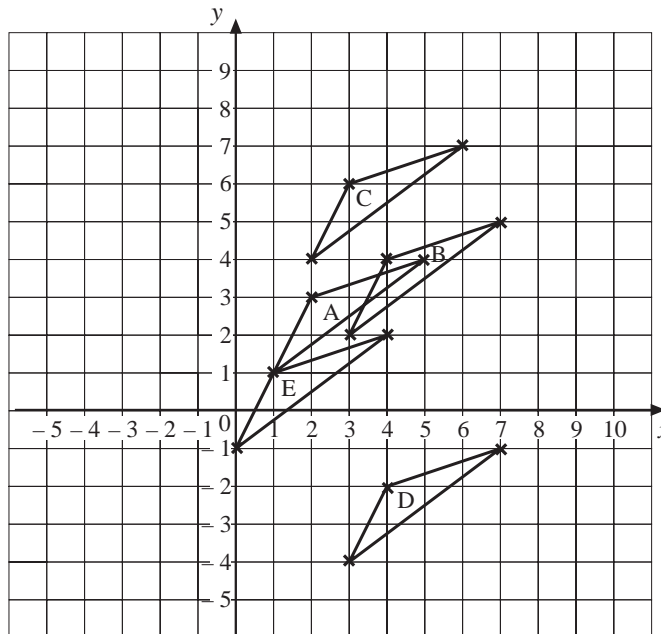

4. A to B $\begin{pmatrix} 3 \\ 4 \end{pmatrix}$ A to C $\begin{pmatrix} 5 \\ -11 \end{pmatrix}$ A to D $\begin{pmatrix} -3 \\ -9 \end{pmatrix}$
 A to E $\begin{pmatrix} -15 \\ -7 \end{pmatrix}$ A to F $\begin{pmatrix} -11 \\ -3 \end{pmatrix}$ A to G $\begin{pmatrix} -12 \\ 4 \end{pmatrix}$

5. (a) $\begin{pmatrix} 5 \\ 3 \end{pmatrix}$ (b) (11, 4)

7.2

Answers

6. (a) $\begin{pmatrix} 6 \\ 3 \end{pmatrix}$ (b) $\begin{pmatrix} 6 \\ -4 \end{pmatrix}$ (c) $\begin{pmatrix} 12 \\ -1 \end{pmatrix}$

The relationship is $\begin{pmatrix} 6 \\ 3 \end{pmatrix} + \begin{pmatrix} 6 \\ -4 \end{pmatrix} = \begin{pmatrix} 12 \\ -1 \end{pmatrix}$, i.e. for the top numbers (the x movement), $6 + 6 = 12$ and for the bottom numbers (the y movement), $3 + (-4) = -1$.

7. (a) Parallelogram
 (c) Translation by the vector $\begin{pmatrix} -1 \\ 0 \end{pmatrix}$

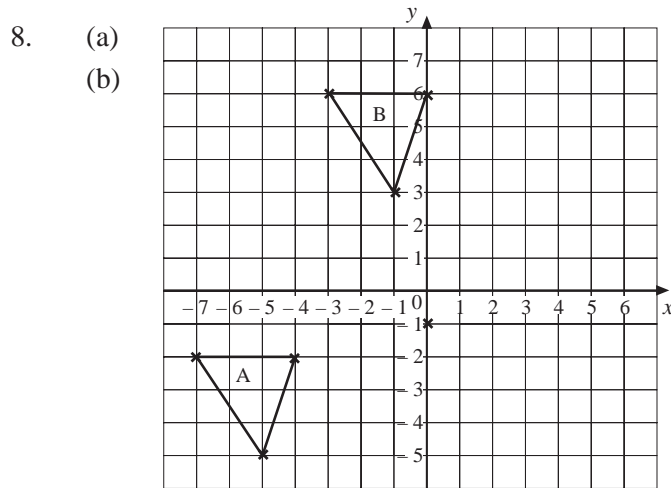
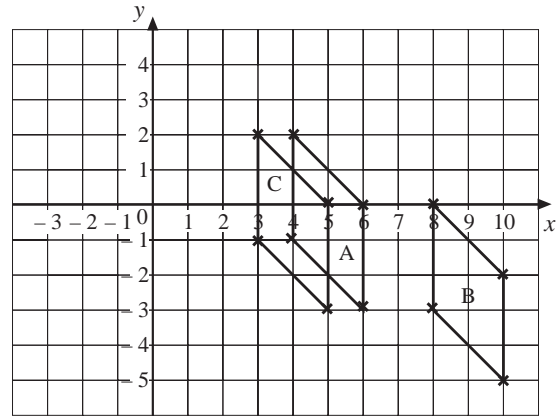

- (c) $\begin{pmatrix} -4 \\ -8 \end{pmatrix}$

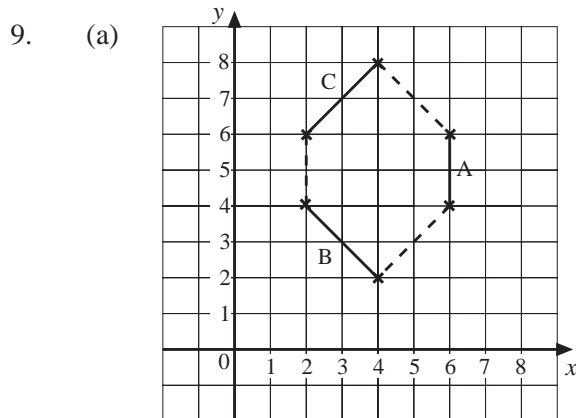

- (b) $A \rightarrow \begin{pmatrix} -4 \\ 0 \end{pmatrix}$
 $B \rightarrow \begin{pmatrix} 2 \\ 4 \end{pmatrix}$
 $C \rightarrow \begin{pmatrix} 2 \\ -4 \end{pmatrix}$

7.2

Answers

10. (a)

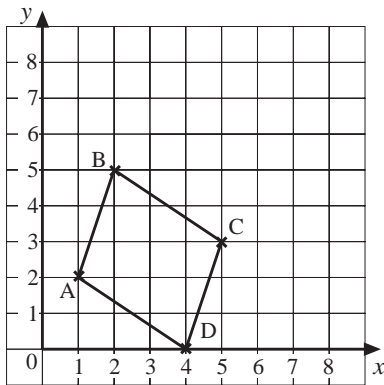

(b) AB to DC $\begin{pmatrix} 3 \\ -2 \end{pmatrix}$
 AD to BC $\begin{pmatrix} 1 \\ 3 \end{pmatrix}$

7.3 Enlargements

1. (a) 2 (b) 2 (c) 6
 (d) 4 (e) $1\frac{1}{2}$ (f) $\frac{1}{2}$

2. (a) An accurately drawn $2\text{ cm} \times 4\text{ cm}$ rectangle.
 (b) Accurately drawn $4\text{ cm} \times 8\text{ cm}$, $6\text{ cm} \times 12\text{ cm}$, $8\text{ cm} \times 16\text{ cm}$ and $1\text{ cm} \times 2\text{ cm}$ rectangles.
 3. (a) An accurately drawn triangle with sides 3 cm , 4 cm and 5.5 cm .
 (b) Accurately drawn triangles with sides 6 cm , 8 cm and 11 cm and 9 cm , 12 cm and 16.5 cm .

4.

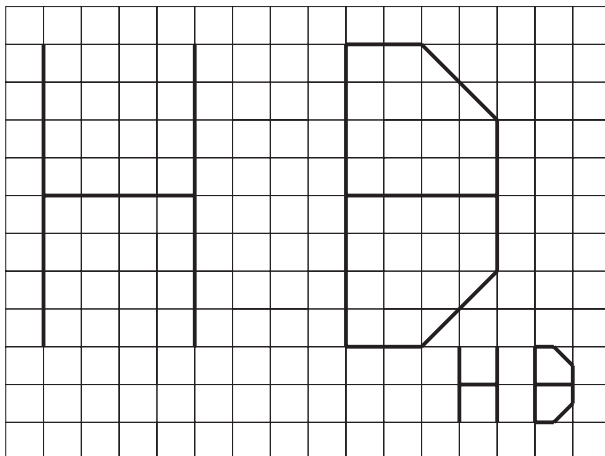

Scale factor 2

Scale factor $\frac{1}{2}$

7.3

Answers

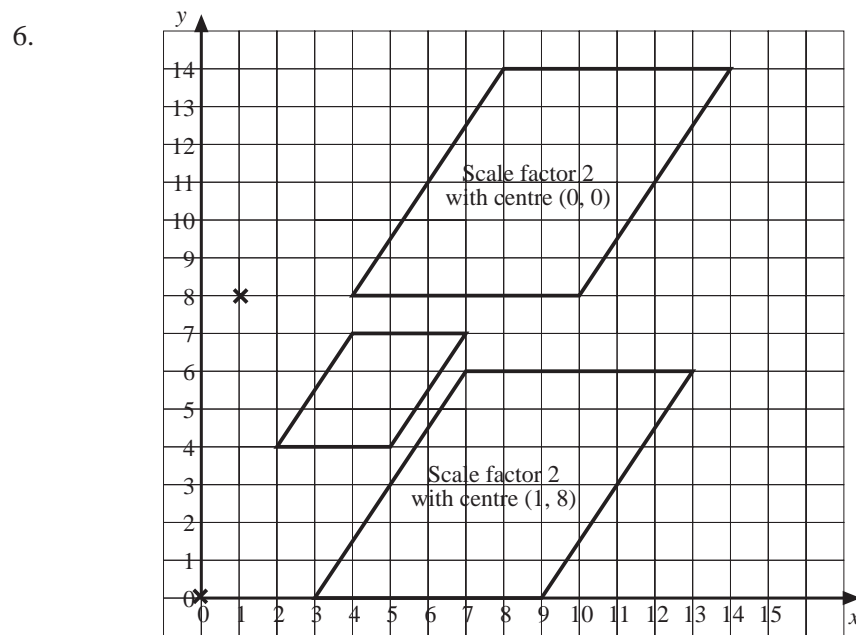
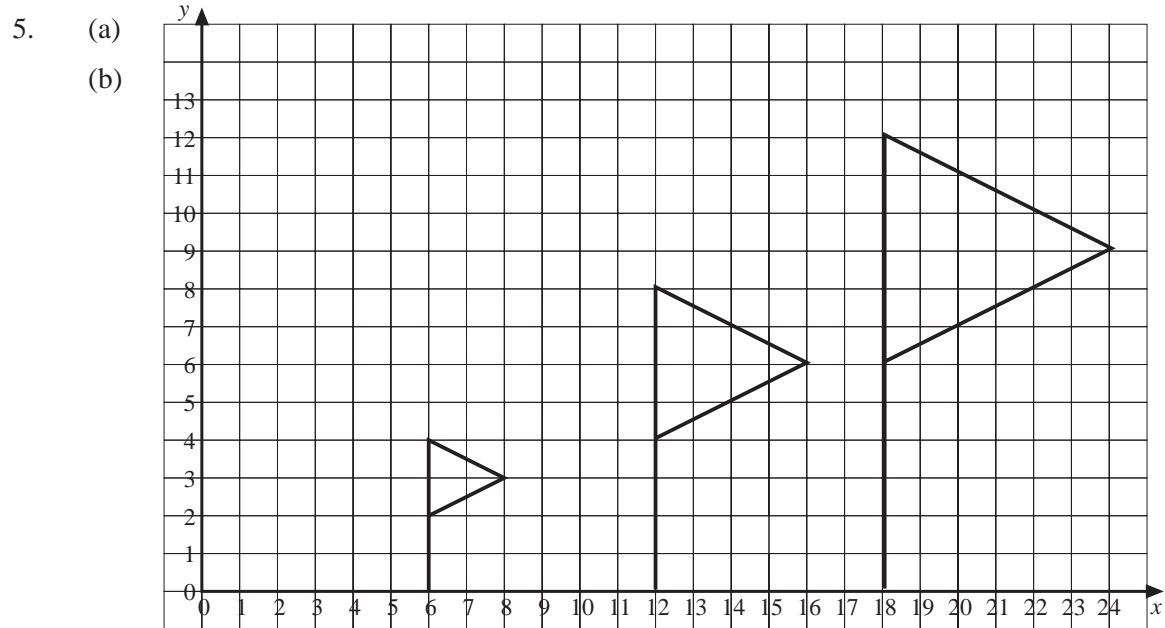

7.3

Answers

7.

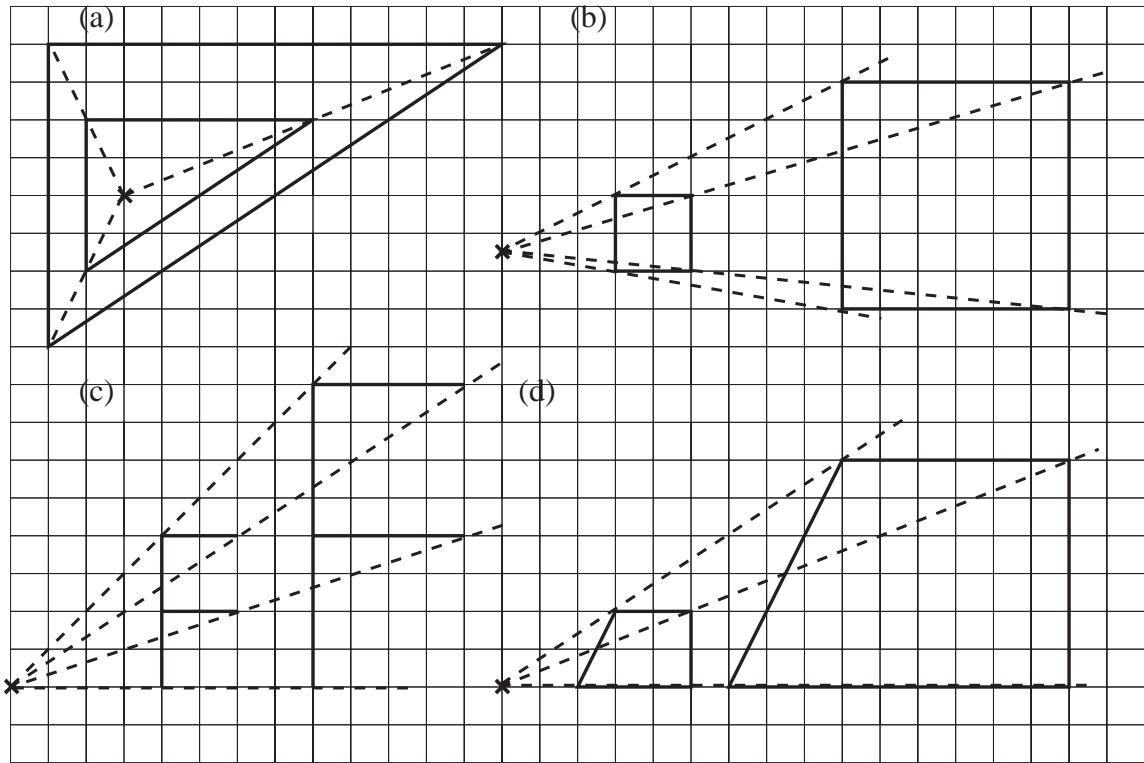

8.

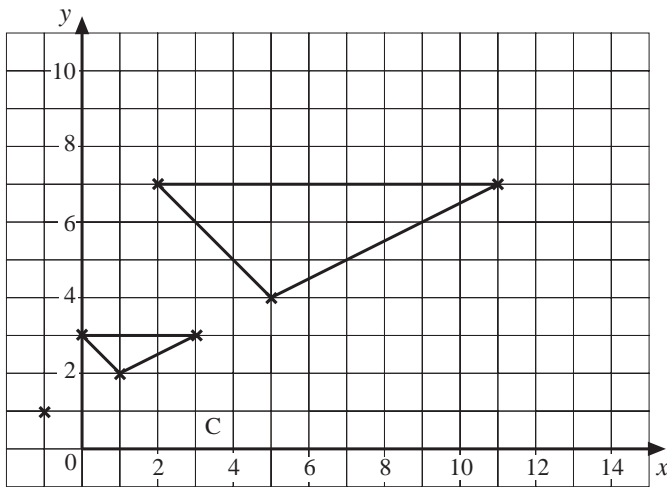

Scale factor = 3.
Centre of enlargement is at (-1, 1).

7.3

Answers

9.

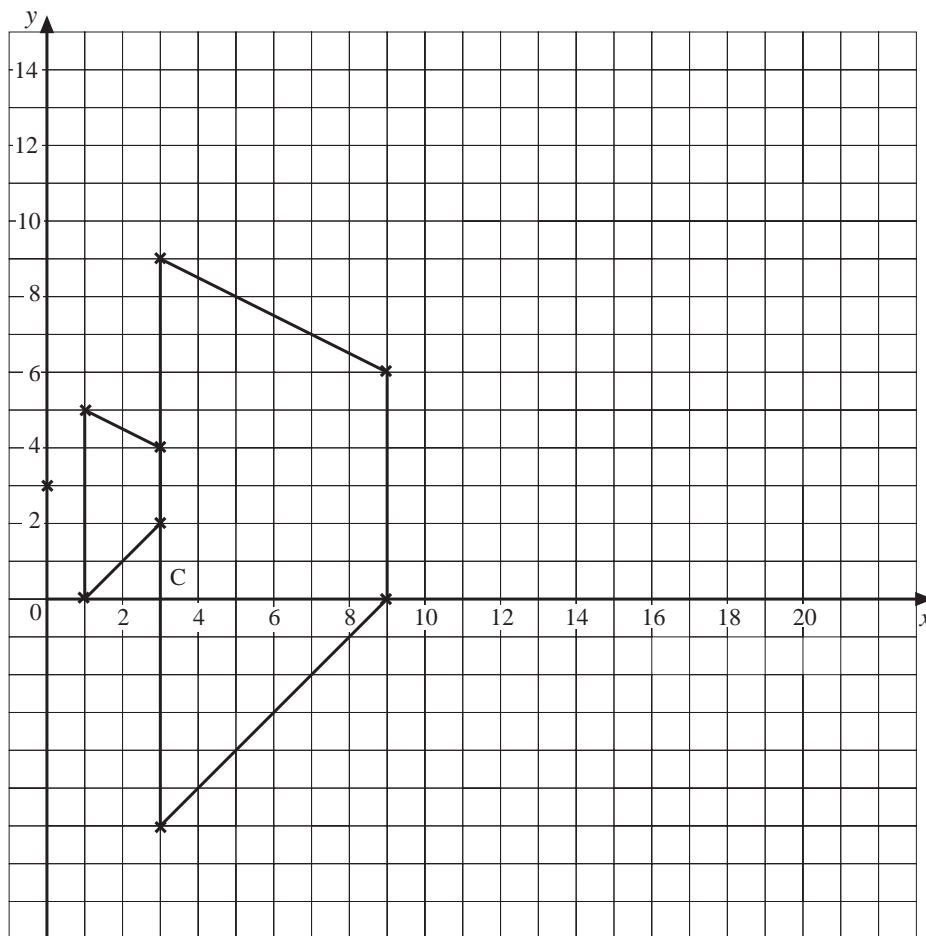

Corners of enlarged trapezium are at $(3, -6)$, $(3, 9)$, $(9, 6)$ and $(9, 0)$.

10.

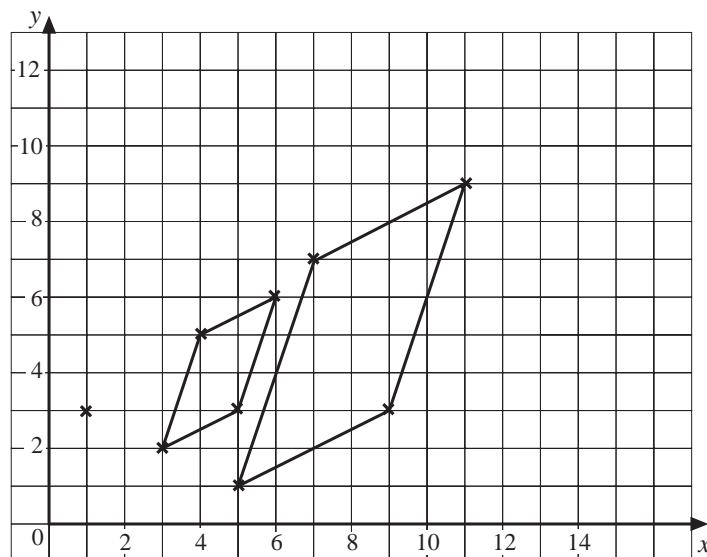

11. (a) The scale factor for heights must be at most $24 \div 6.5 = 3.692$ (to 3 d.p.);
 the scale factor for widths must be at most $12 \div 4 = 3$,
 so the maximum scale factor Jill can use is 3.

7.3

Answers

- (b) The scale factor for heights must be at most $2.7 \div 6.5 = 0.415$ (to 3 d.p.);
 the scale factor for widths must be at most $2.7 \div 4 = 0.675$,
 so the maximum scale factor Jill can use is 0.415 (to 3 d.p.).
- (c) The perimeter = $(\pi \times 6.6) + (2 \times 6.6)$
 $= 33.93451151$ cm
 $= 33.93$ cm (to 2 d.p.)

7.4 Reflections

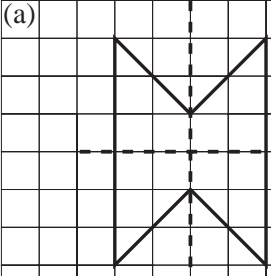
1. (a) 

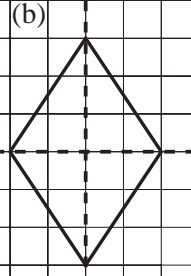
(b) 

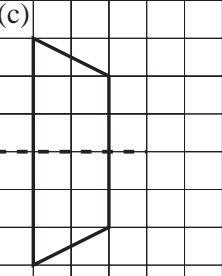
(c) 

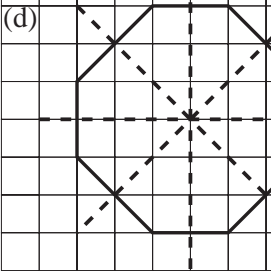
(d) 

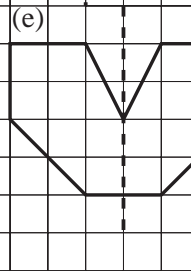
(e) 

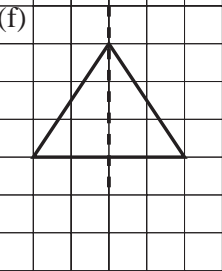
(f) 

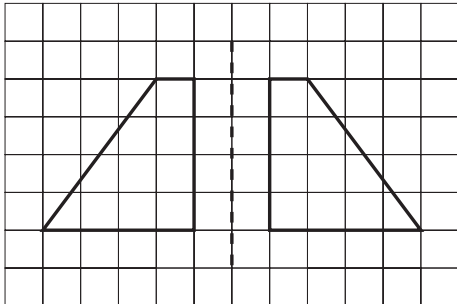
2. (a) 

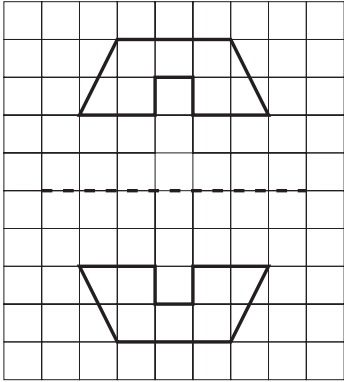
(b) 

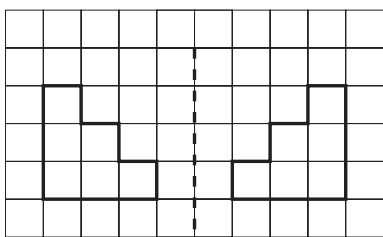
(c) 

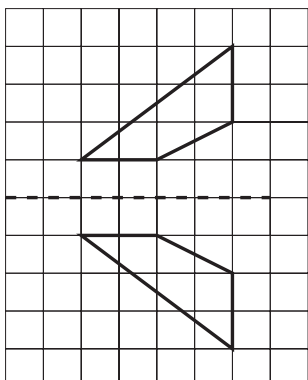
(d) 

7.4

Answers

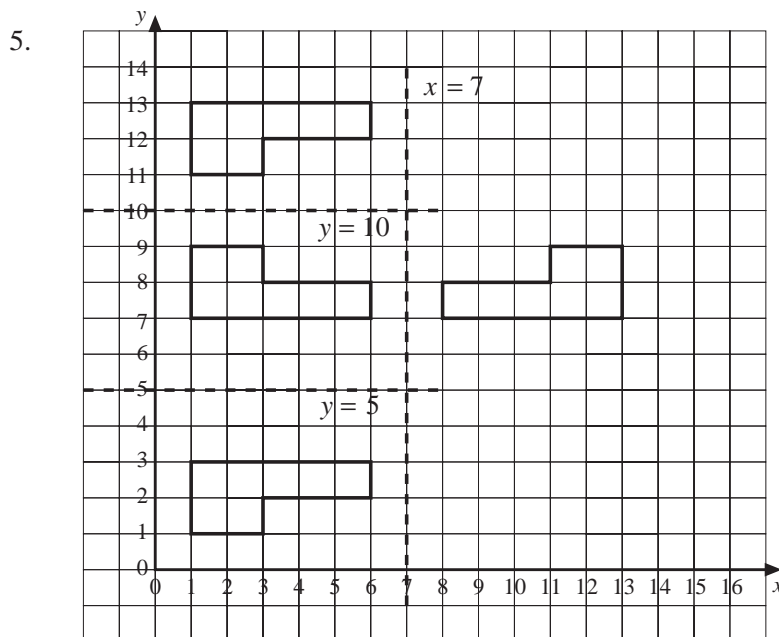
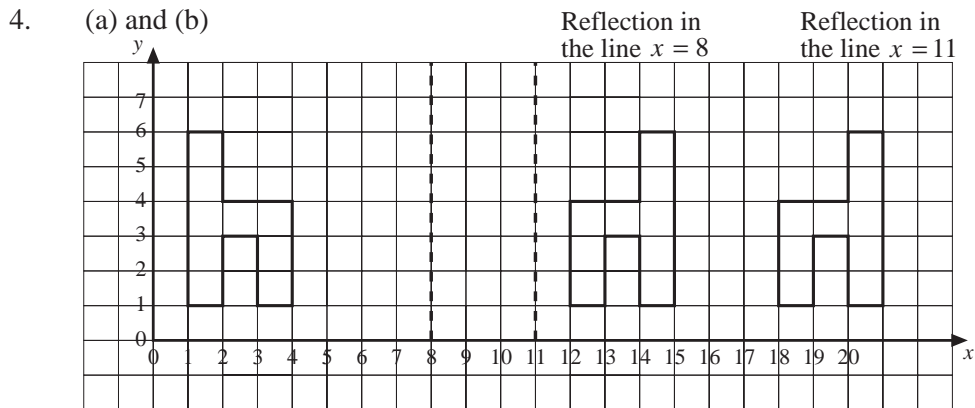
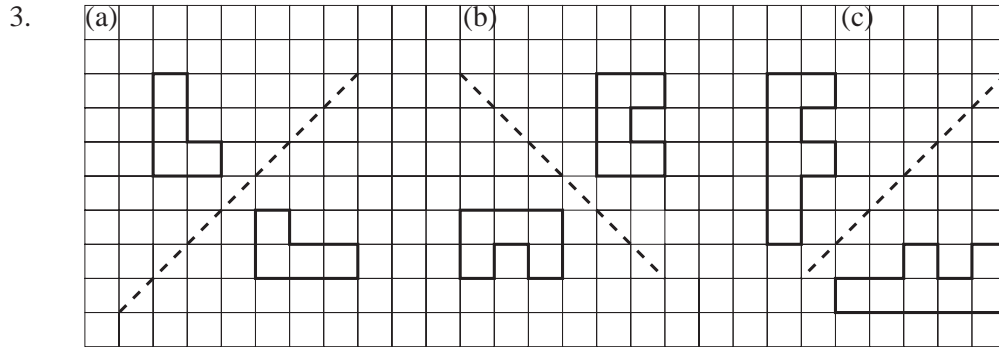
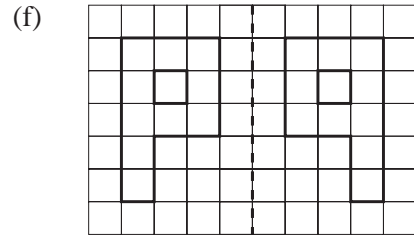
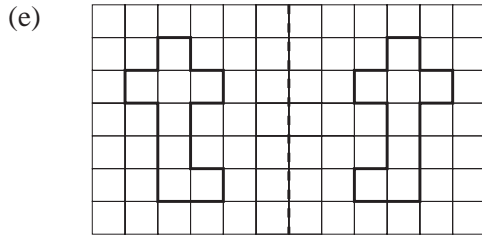

7.4

Answers

6. (a) and (b)

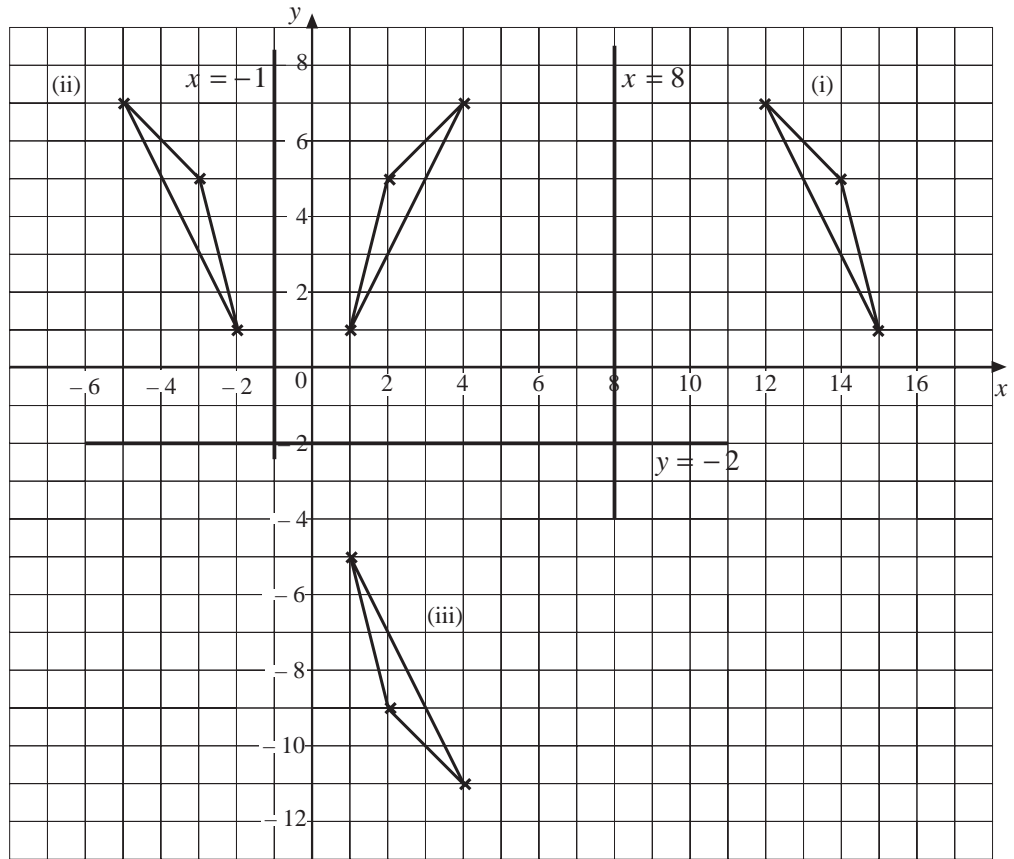

7. (a) $x = 5$ (b) $x = 9$ (c) $x = 10$
 (d) $x = 16$ (e) $x = 21$ (f) $x = 14$

8. (a)

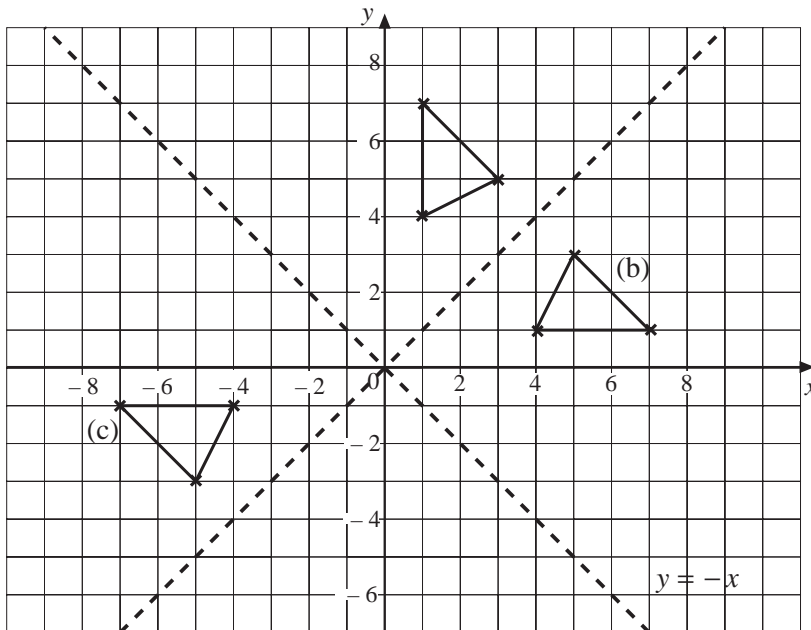

7.4

Answers

9. (a)

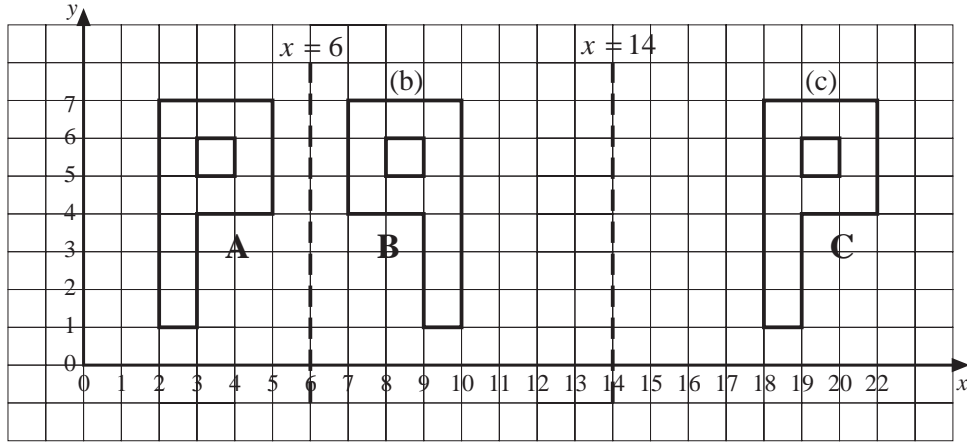

(d) Translation $\begin{pmatrix} 16 \\ 0 \end{pmatrix}$

10.

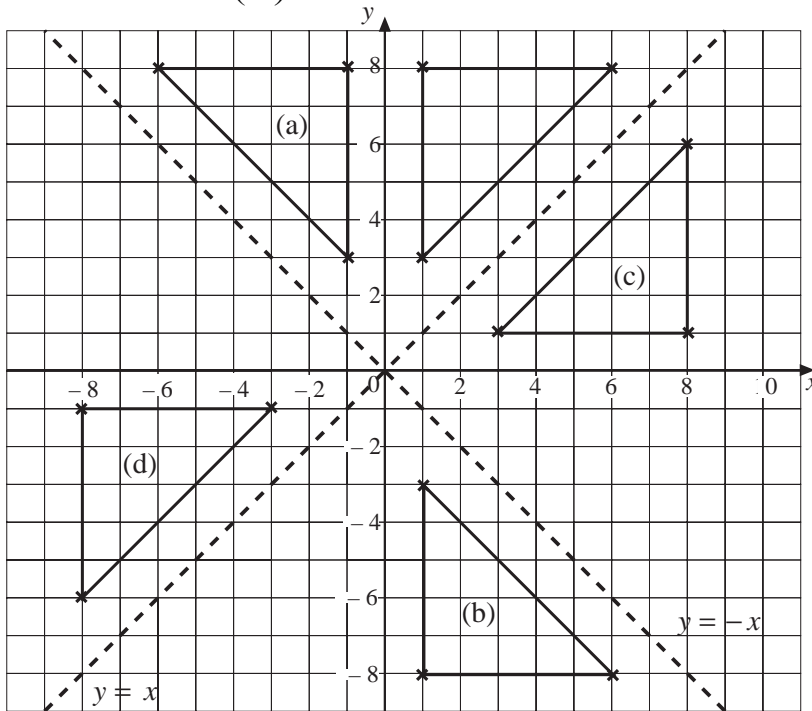

11.

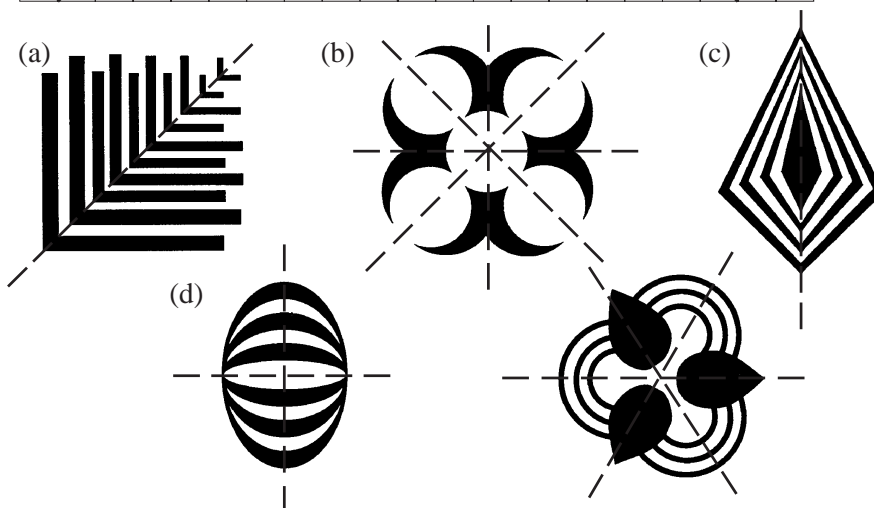

7.4

Answers

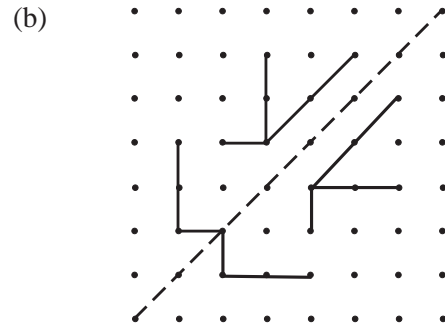
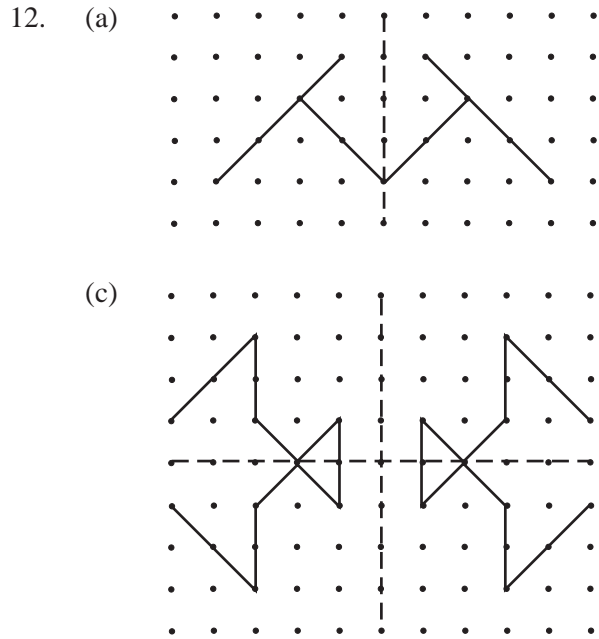

13. (a) $x = y$ (b) $14\frac{1}{2}$
- (c) (10, 12) is above the line because its y -coordinate is greater than its x -coordinate.
- (d) Any x -coordinate less than 15, e.g. (13, 15).
- (e) Coordinates reversed
- (f) (13, 20)

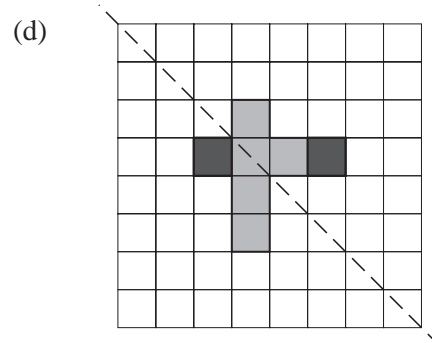
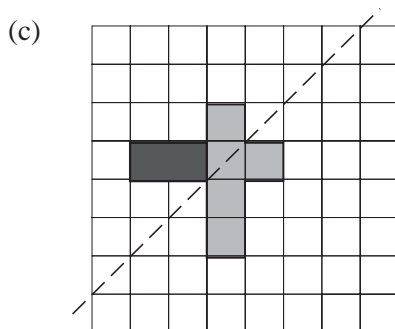
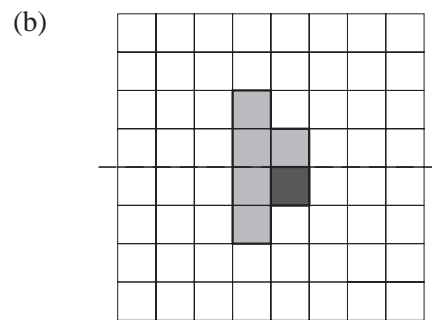
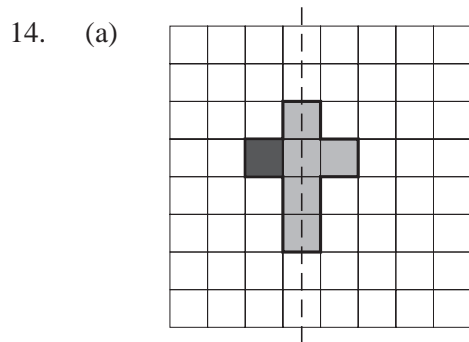

7.5

Answers

7.5 Rotations

1. (a) 2 (b) 4 (c) 1
 (d) 3 (e) 4 (f) 6
2. H, I, N, O, S, X, Z (depending on how the letters are printed or written)

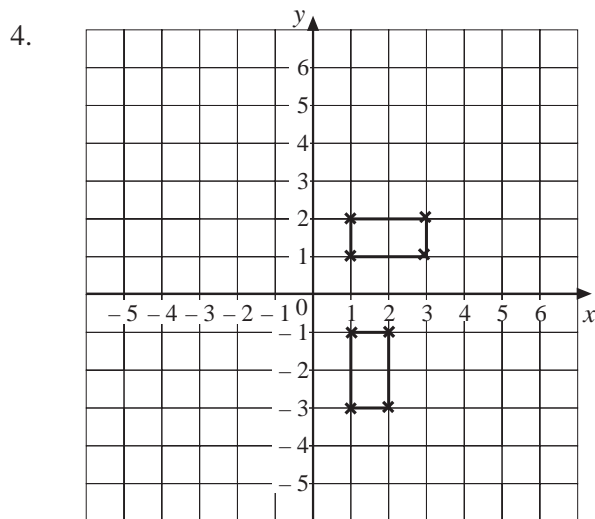
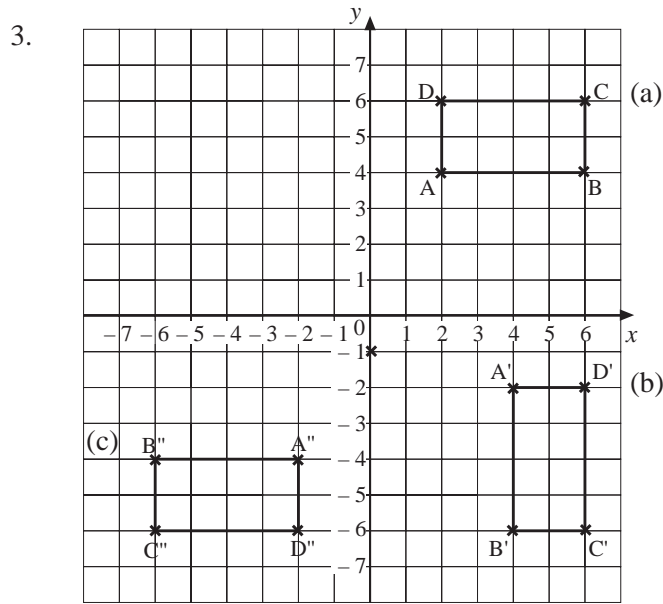

7.5

Answers

5.

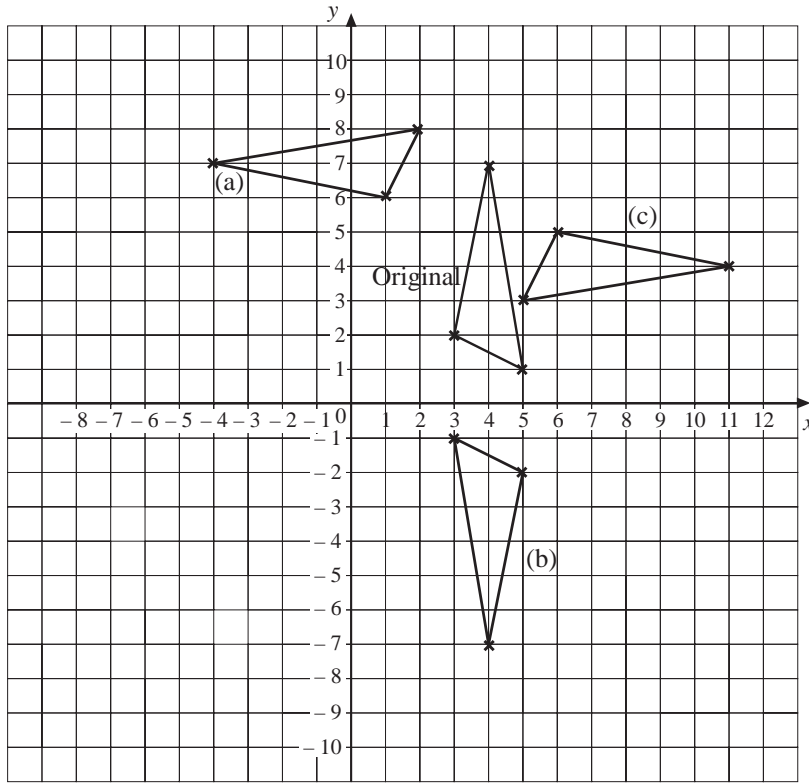

- (a) (1, 6), (2, 8), (-4, 7)
- (b) (3, -1), (4, -7), (5, -2)
- (c) (5, 3), (11, 4), (6, 5)

- 6. (a) Rotation through 90° clockwise about the origin (0, 0)
- (b) Rotation through 180° about the origin (0, 0)
- (c) Rotation through 90° anticlockwise about the origin (0, 0)
- (d) Rotation through 180° about (8, 0).
- 7. (a) Rotation through 90° clockwise about (5, 1)
- (b) Rotation through 90° clockwise about the origin (0, 0)
- (c) Rotation through 180° about the origin (0, 0)
- (d) Rotation through 90° anticlockwise about (0, 1).

8.

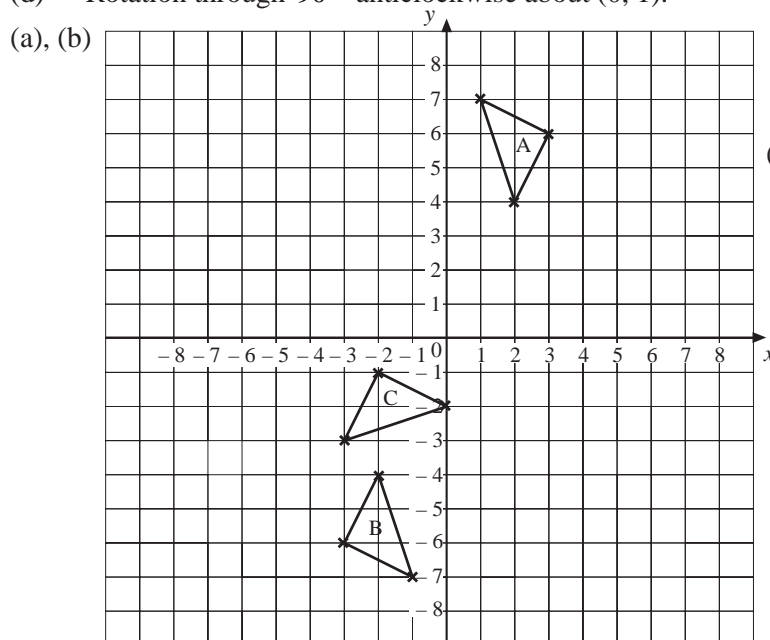

- (c) Corners of triangle C have coordinates (-3, -3), (-2, -1), (0, -2)

7.5

Answers

9. (a) (6, 7) (b) (1.5, 7.5)

10. Rotation clockwise through 90° about the point (2, 1) (as diagram).

11. *Lines of Symmetry*

| | | 0 | 1 | 2 | 3 |
|-------------------------------------|---|---|---|---|---|
| <i>Order of Rotational Symmetry</i> | 1 | E | F | | |
| | 2 | B | | C | |
| | 3 | D | | | A |

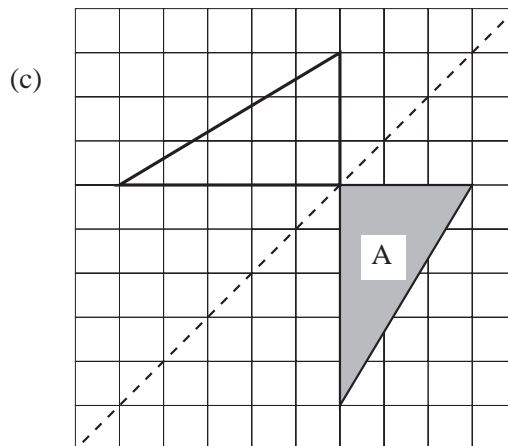
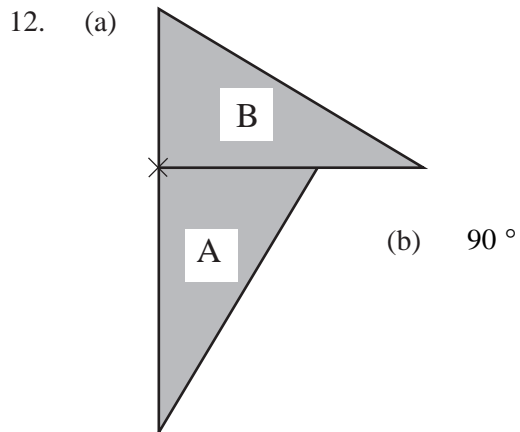
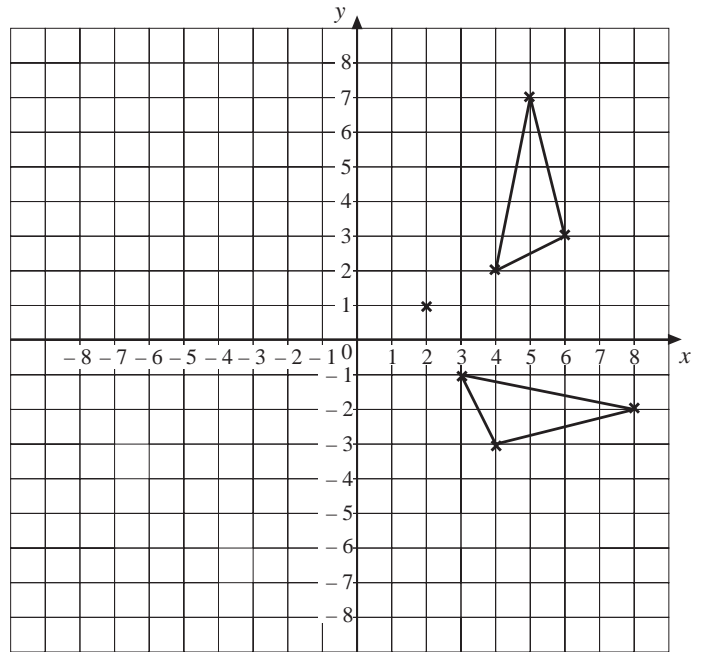

13. (a) B1 Rotate 90° clockwise and then rotate 90° clockwise again.
 B2 Reflect vertical
- (b) A2 Rotate 90° clockwise and then rotate 90° clockwise again.
 B1 Reflect vertical and then rotate 90° clockwise.
 B2 Rotate 90° clockwise.

7.6

Answers

7.6 Combining Transformations

1. (a)

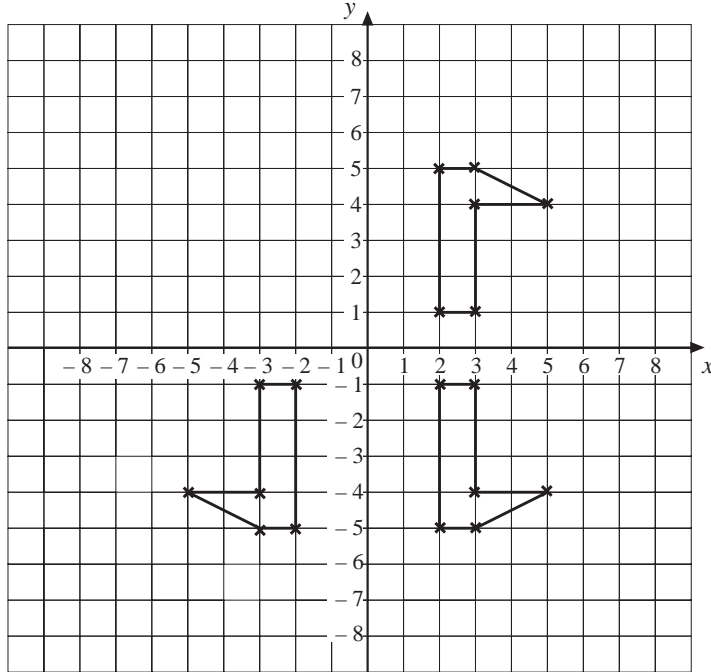

(b) Rotation of 180° about the origin.

2. (a)

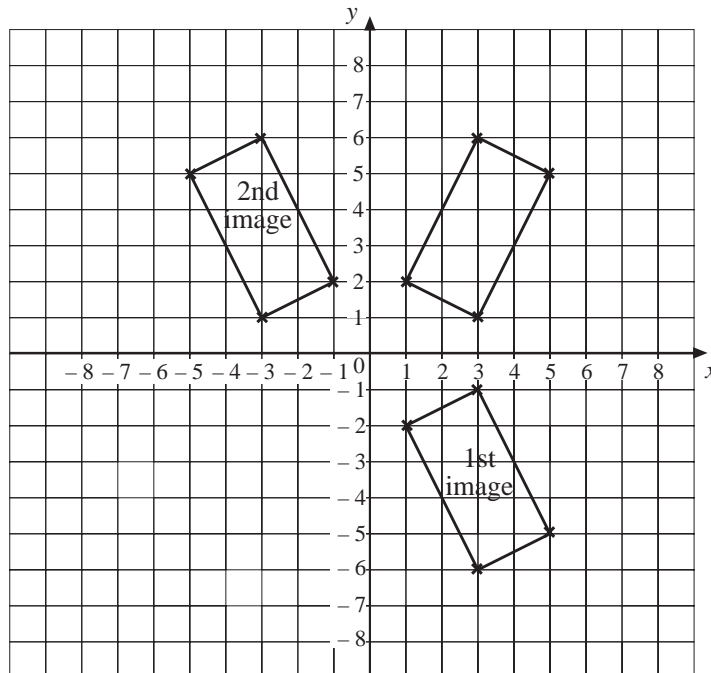

(b) The single transformation is a reflection in the y-axis.

7.6

Answers

3. (a)

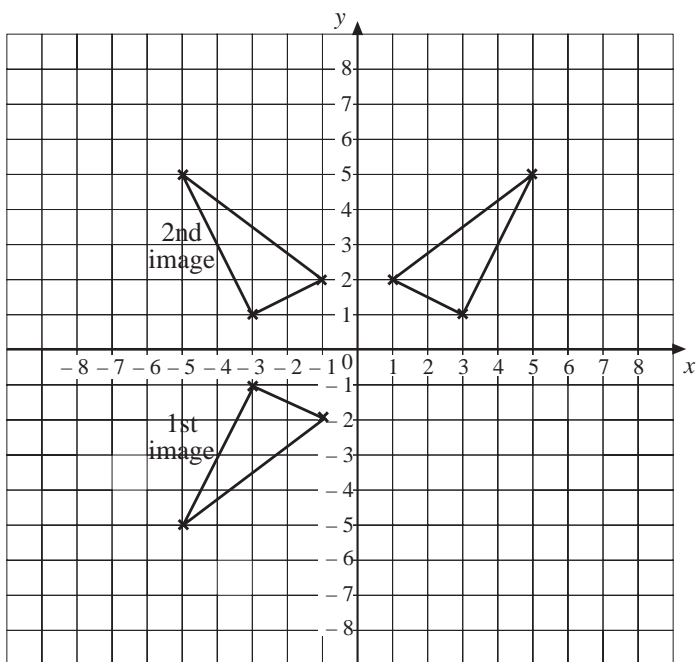

(b) The single transformation is a reflection in the y-axis.

4. (a), (b)

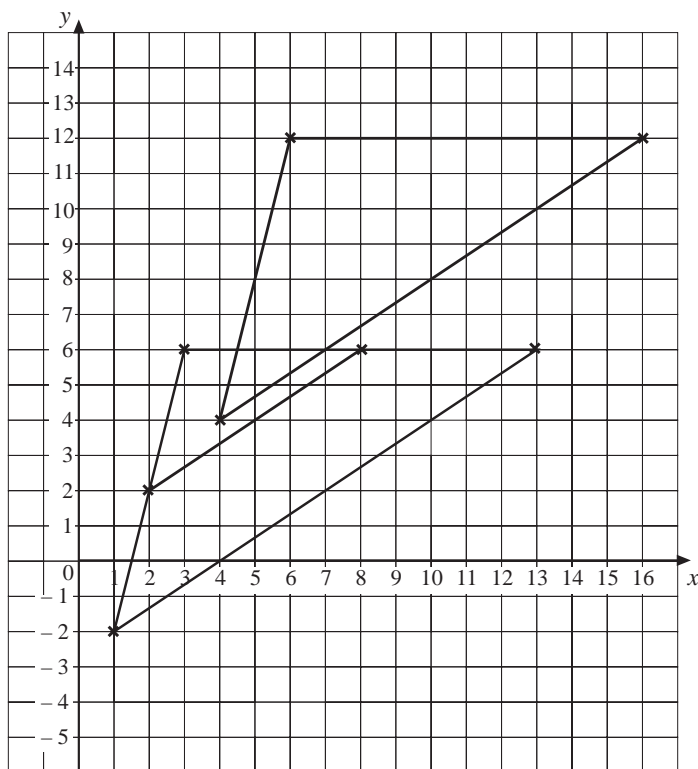

(c) Enlargement, centre (3, 6), scale factor 2.

7.6

Answers

5.

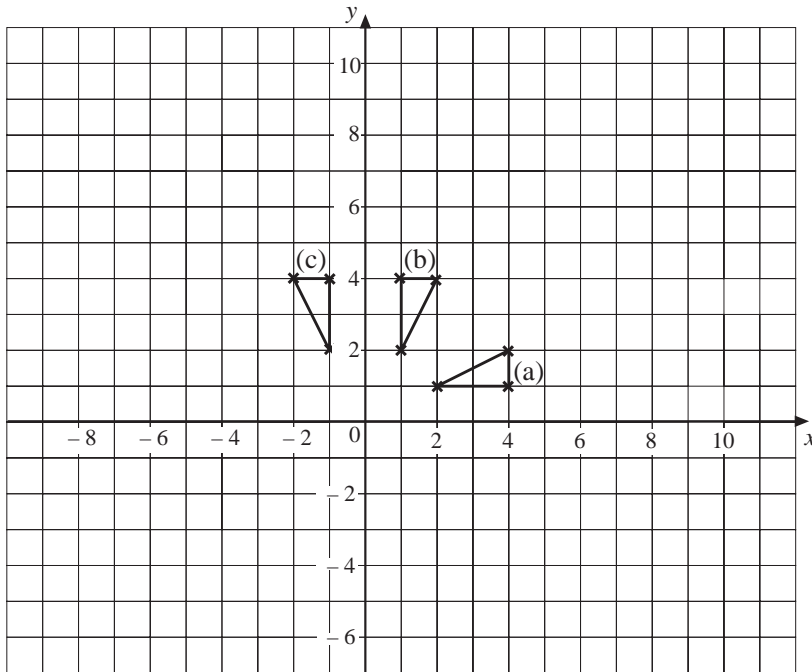

(d) 90° anticlockwise rotation about the origin.

6. (a) For example,

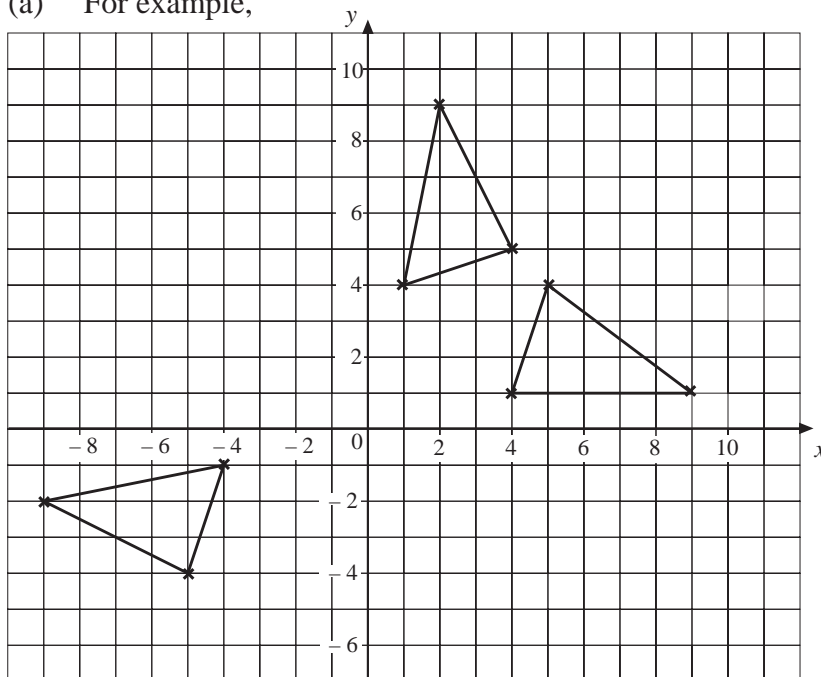

(b) 180° anticlockwise rotation about the origin.

7.6

Answers

7. (a)

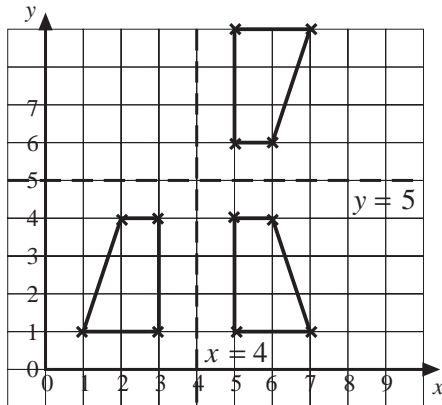

(b) 180° rotation about (4, 5).

8. (a)

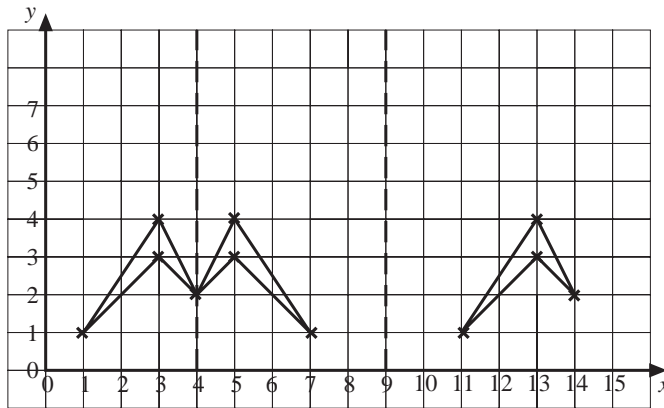

(b) There are many ways of doing this; one of the easiest is to reflect the original chevron in the line $x = 4$ and then to reflect its image in the line $x = 9$, as in the diagram.

9. (a), (b)

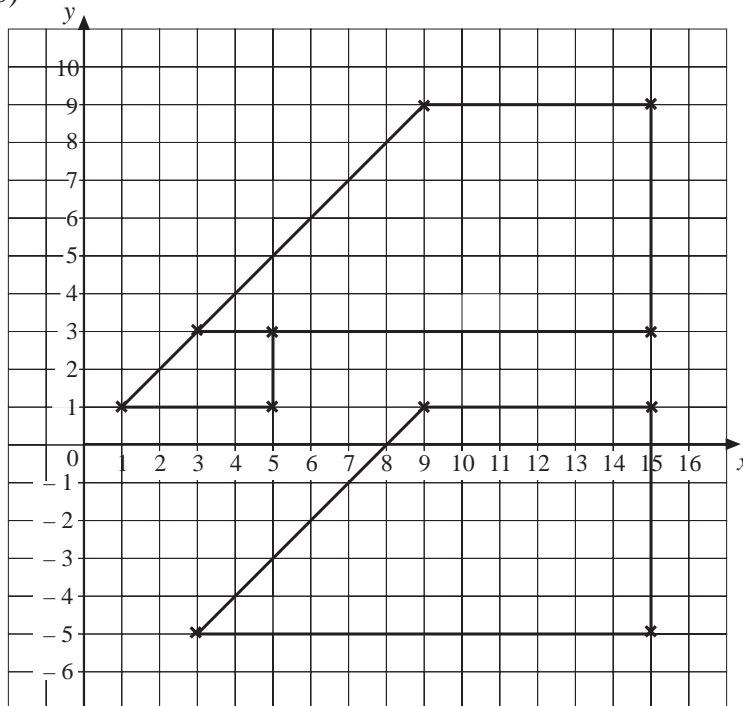

(c) Enlargement, scale factor 3, centre (4, 0).

7.6

Answers

10.

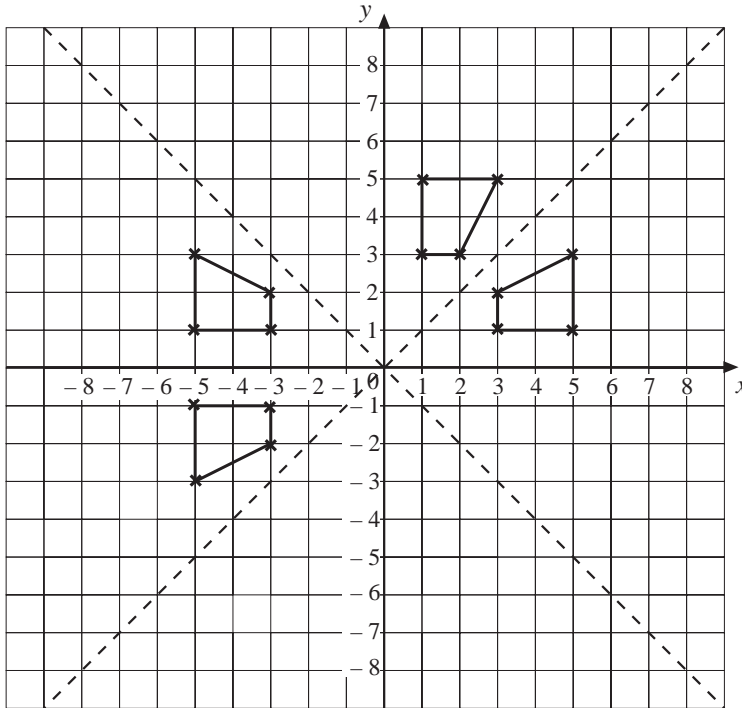

Single transformation is a reflection in the y-axis.

11. There are 5 possible combinations, for any suitable value of k :

- rotate through 90° anticlockwise about $(k, k-1)$ then reflect in the line $x = k + 2$, e.g. rotate 90° anticlockwise about $(3, 2)$ then reflect in the line $x = 5$,
- reflect in the line $y = k - 3$ then rotate through 90° anticlockwise about $(k, k-1)$,
- rotate through 90° anticlockwise about $(k, k-5)$ then reflect in the line $y = k - 3$.
- reflect in the line $x = k - 2$ then rotate through 90° clockwise about $(k, k-5)$,
- reflect in the line $y = k - x$ then rotate through 180° about $\left(\frac{k+5}{2}, \frac{k+5}{2} - 3\right)$.

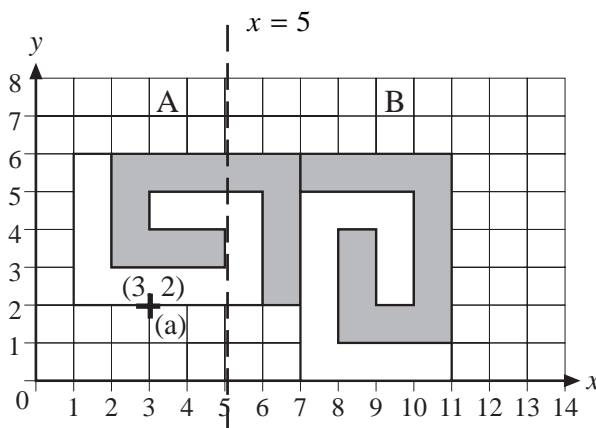

Practice Book *UNIT 8 Statistical Diagrams*

Answers

8.1 Data Collection, Extraction and Presentation

1. (a) 14 miles (b) 48 miles (c) 54 miles (d) 114 miles
 (e) No: Cambridge to Northampton is 50 miles and Cambridge to Wellingborough is only 44 miles.
2. (a) 870 km (b) 1135 km (c) 574 km (d) 577 km
3. (a) 1528 (b) 1540 (c) 1551 (d) 1603 (e) 1709
 (f) Board the 1512 to Shirley arriving at 1526; then board the 1543 to Earlswood, arriving 1551.
4. (a) 1320 (b) 1117 (changing at Weston-super-Mare) (c) 1435
 (d) 1244 (e) 1745 (f) 1730

5. (a)

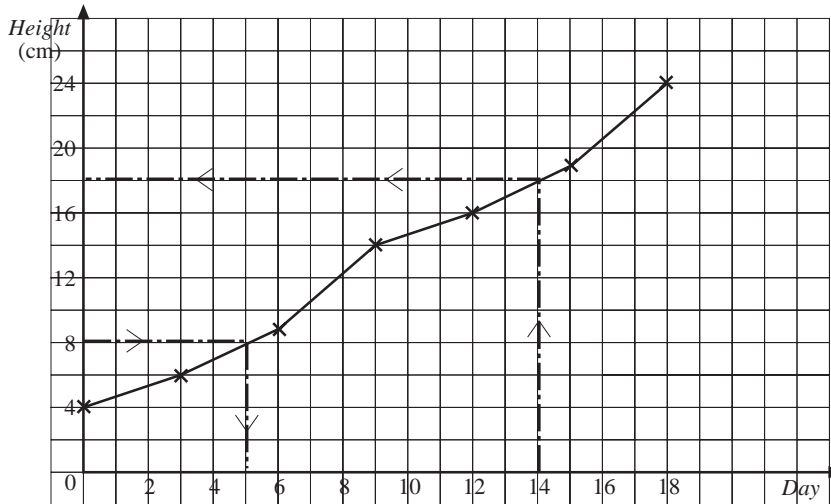

(b) About 18 cm

(c) About 5 days

6. (a)

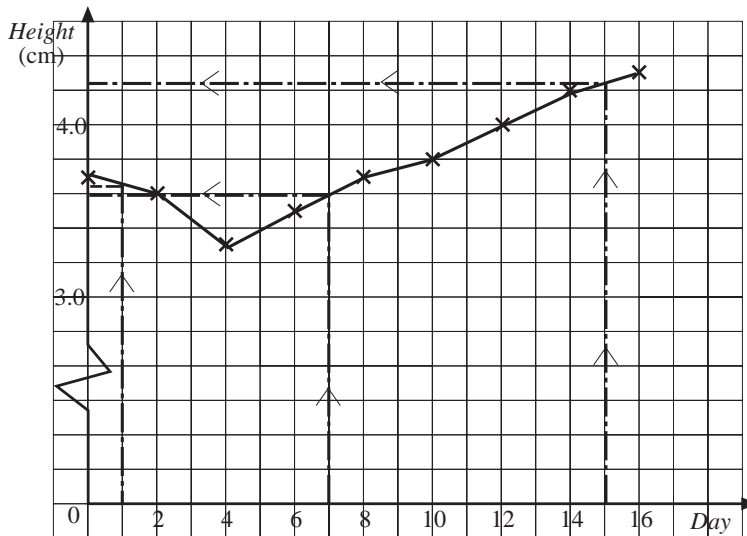

(b) Day 1 Mass \approx 3.65 kg

Day 7 \approx 3.60 kg

Day 15 \approx 4.25 kg

8.1

Answers

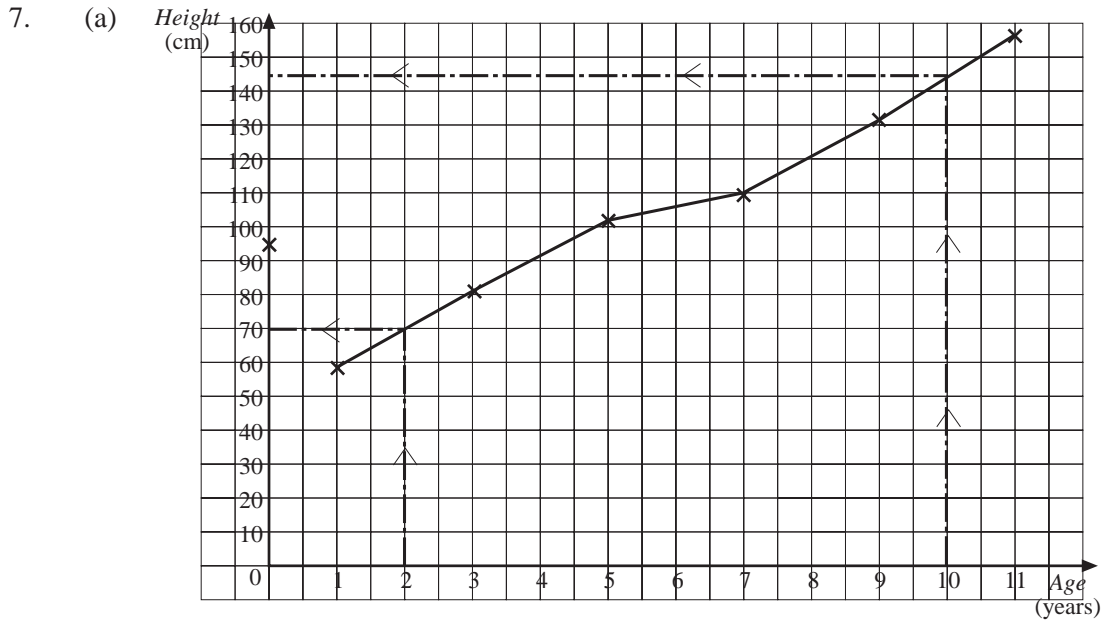

- (b) Age 2 Height \approx 70 cm
 Age 10 Height \approx 144 cm

8.

| Stem | Leaf |
|------|---------------------|
| 0 | 2 9 9 |
| 1 | 1 1 7 7 8 9 9 |
| 2 | 2 2 4 7 8 9 9 |
| 3 | 1 1 2 2 3 4 5 8 8 9 |
| 4 | 0 0 2 |







9. (a)

| No. of Children | Tally | Frequency |
|-----------------|-------|-----------|
| 0 | | 0 |
| 1 | | 11 |
| 2 | | 14 |
| 3 | | 9 |
| 4 | | 3 |
| 5 | | 2 |
| 6 | | 1 |

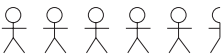
8.1

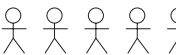
Answers

(b) *Pictogram Showing Number of Children per Family*

| | | |
|------------|---|---|
| 1 child |  | Each symbol  represents 2 families |
| 2 children |  | |
| 3 children |  | |
| 4 children |  | |
| 5 children |  | |
| 6 children |  | |

(c) *Vertical Line Graph Showing Number of Children per Family*

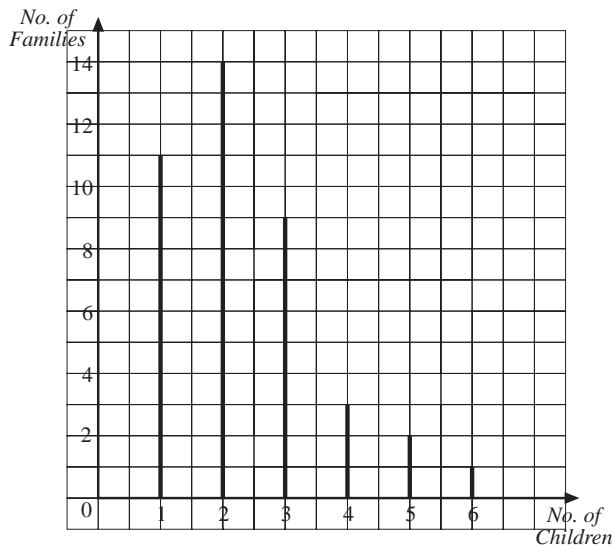

10. *Vertical Line Graph Showing Number of Children Against Amount Spent in Tuckshop*

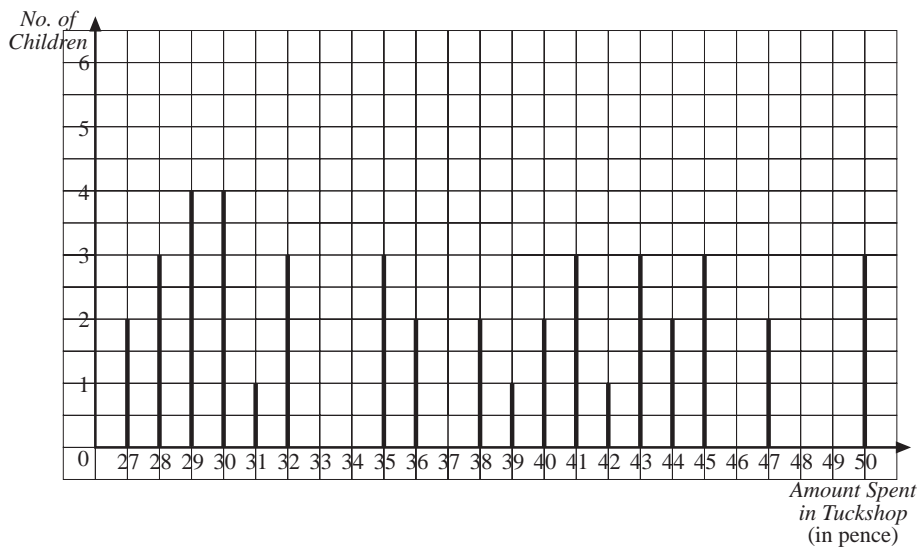

8.1

Answers

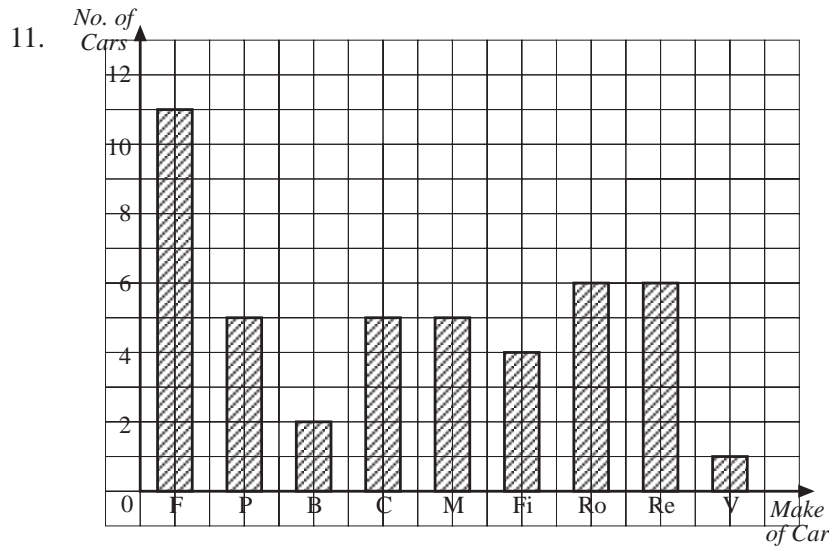

12. (a) 60 (b) 45 (c) About 25
 (d) and (e)

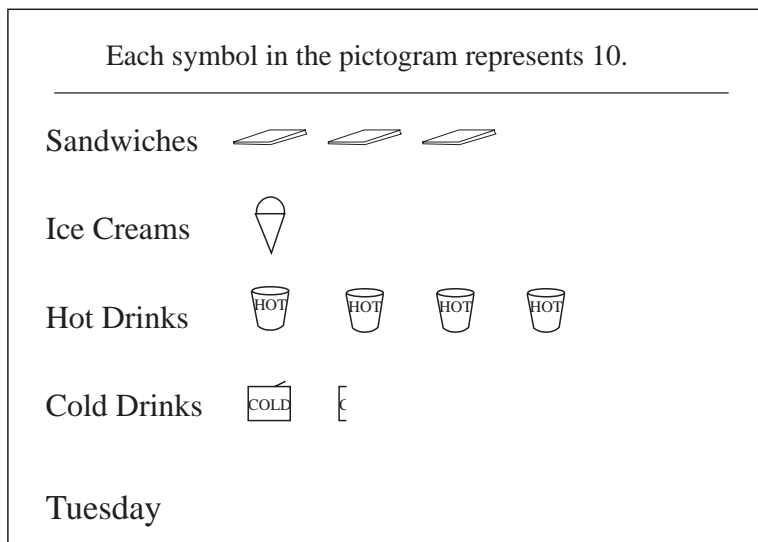

- (f) Since more ice creams and cold drinks were bought on Monday than on Tuesday, it is likely that Tuesday was a colder day than Monday.

13. (a) (i) 0915 (ii) 45 minutes (b) 0930 (c) £11.00

14. (a)

| Size of Trainers | Tally | Total Sold During Week |
|------------------|-------|------------------------|
| 4 | | 5 |
| 5 | | 6 |
| 6 | | 5 |
| 7 | | 8 |
| 8 | | 3 |
| 9 | | 2 |

- (b) Size 7
 (c) Count up number sold of sizes 4, 5, 6 and compare with number sold of sizes 7, 8, 9.

8.1

Answers

15. (a) 318 miles (b) 380 miles (c) Liverpool
 (d) Plymouth and Liverpool (e) Edinburgh (f) London

(g)

| <i>From</i> | <i>To</i> | <i>Distance (miles)</i> |
|-------------|-----------|-------------------------|
| Edinburgh | Newcastle | 107 |
| Newcastle | London | 280 |

16. (a) Add up the bar heights from the first diagram: $10 + 8 + 6 + 5 + 1 = 30$ days
 (b) Sue was right. There are 5 days with 15 to 20 mm of rainfall, so these 5 days produce more than 75 mm of rainfall, which makes all the other suggestions wrong.
 (c) Sudi is wrong because the horizontal axis does not record the days of the month, merely the amount of rainfall, so you cannot tell which days in the month produced the high rainfall.

17. (a) (i) 20 (ii) 40%
 (b) Angles in pie chart:
 36° , 144° and 180°

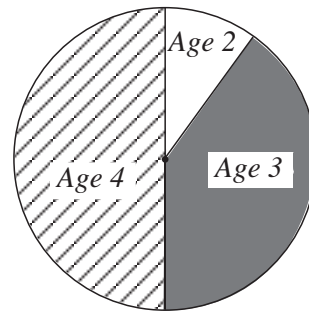

8.2 Statistical Measures

1. (a) Mode = 1 day (b) Median = 1 day (c) Mean = $\frac{40}{30} = 1\frac{1}{3}$ days
 (d) Range $6 - 0 = 6$ days
2. (a) (i) Mode = 4 people (ii) Median = $\frac{3 + 3}{2} = 3$ people
 (ii) Mean = $\frac{106}{31} = 3\frac{13}{31} = 3.42$ (to 2 d.p.)
 (b) Mode – takes no account of daily variations.

3. (a) Amount spent most often.

(b)

| <i>Amount of Money Spent</i> | <i>Time</i> | | | <i>Total Number of People Who Spent Each Amount</i> |
|------------------------------|-------------------------|-------------------------|-------------------------|---|
| | <i>5 p.m. to 6 p.m.</i> | <i>6 p.m. to 7 p.m.</i> | <i>7 p.m. to 8 p.m.</i> | |
| Under 50p | | | | 7 |
| 50p to 99p | | | | 10 |
| £1.00 to £1.49 | | | | 4 |
| Over £1.49 | | | | 3 |

8.2

Answers

- (c) Yes, Len is right – '50p to 99p' is the modal class for the way he has grouped the data.
 - (d) Smaller amounts spent earlier in the evening. Maybe older people with more money to spend attend later in the evening, etc.
4. (a) September (b) May, June, October, November, December
- (c) January, February, December
5. (a) Classes Q, R and T (b) B and D

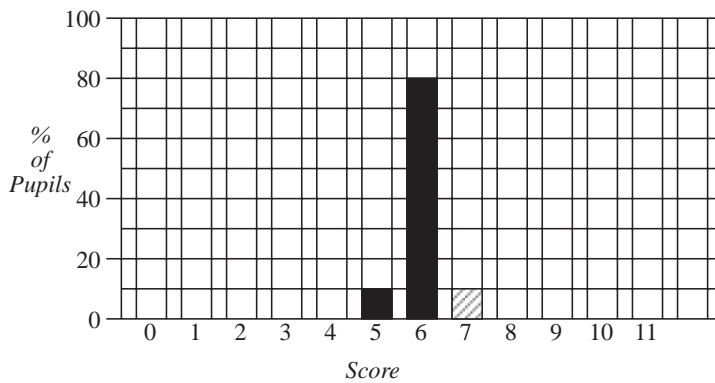

6. (a) Cannot tell – graph shows only the total number of lengths swum by each year group, not how many pupils swam them.
- (b) Mean = $\frac{150 + 210 + 230 + 170 + 70}{80} = \frac{830}{80} = 10.375$ lengths/pupil

(c)

| <i>Number of lengths</i> | <i>Class Midpoint</i> | <i>Frequency</i> | <i>Frequency × Midpoint</i> |
|--------------------------|-----------------------|------------------|-----------------------------|
| 1 to 5 | 3 | 12 | 36 |
| 6 to 10 | 8 | 33 | 264 |
| 11 to 15 | 13 | 27 | 351 |
| 16 to 20 | 18 | 6 | 108 |
| 21 to 25 | 23 | 2 | 46 |
| Totals | | 80 | 805 |

Mean = $\frac{805}{80} = 10.0625$ lengths

- (d) Jack's graph uses middle values from grouped data (only approximate) whereas Lara's graph is accurate because it uses actual totals of lengths swum by year groups.
7. (a) 0.8 or 80% (b) 0.6 or 60%
- (c) Mean waiting time = $\frac{274}{100} = 2.74$ minutes
- (See table at top of following page)

8.2

Answers

| Waiting Time (minutes) | Mid-point of bar (x) | Number of Customers (f) | (fx) |
|------------------------|----------------------|-------------------------|------|
| 0 - | 0.5 | 6 | 3 |
| 1 - | 1.5 | 14 | 21 |
| 2 - | 2.5 | 40 | 100 |
| 3 - | 3.5 | 30 | 105 |
| 4 - 5 | 4.5 | 10 | 45 |
| Totals | | 100 | 274 |

(d) For example, record waiting times of customers at *all* check-outs.

8. (a)

| Number of Nuts | Mid-point of Bar (x) | Number of Packets (f) | fx |
|----------------|----------------------|-----------------------|-----|
| 4 - 6 | 5 | 26 | 130 |
| 7 - 9 | 8 | 33 | 264 |
| 10 - 12 | 11 | 20 | 220 |
| 13 - 15 | 14 | 15 | 210 |
| 16 - 18 | 17 | 6 | 102 |
| Totals | | 100 | 926 |

Mean number of nuts in a packet = $\frac{926}{100} = 9.26$

(b) 12 packs

(c) Ranges cannot be worked out exactly as the original raw data has been grouped. However, the range for nuts could only be as high as $18 - 4 = 14$, whilst the range for raisins could be as high as $30 - 6 = 24$ but only as low as $26 - 10 = 16$. This shows that the chart for raisins (chart B) exhibits the greater range.

(d) $\frac{59}{100} = 0.59$ (or 59%)

(e) $\frac{6}{100} \times \frac{23}{100} = \frac{138}{10000} = 0.0138$ (or 1.38%)

8.3 Plotting Scatter Diagrams

- (a) A (b) A

(c) B (d) C
- (a) See diagram opposite

(b) Weak/moderate positive correlation
- (a) Scatter graph

(b) Any correlation is entirely coincidental!

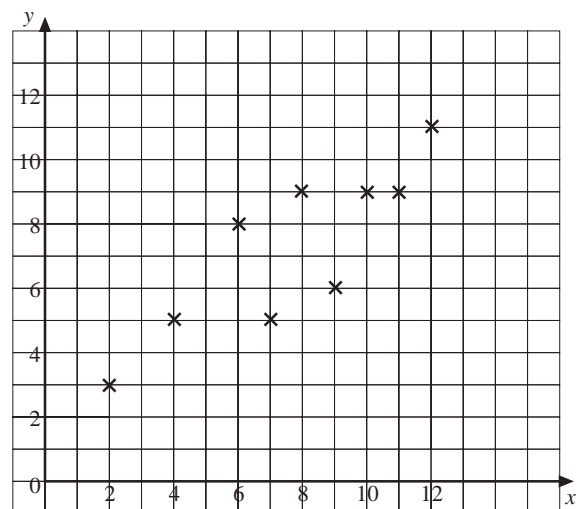

8.3

Answers

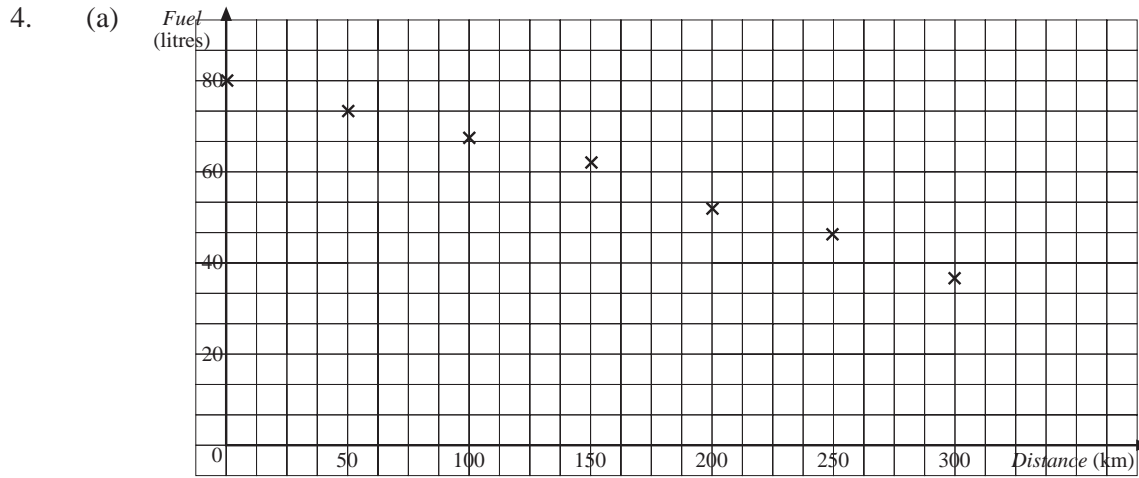

(b) Strong negative correlation

5. (a) Positive correlation for children of a restricted age range (e.g. 5 to 13) but no correlation if you include older teenagers.

(b) No correlation

(c) Possibly strong positive correlation in a single, smallish geographical area. For wider areas with greater mix of housing, little or no correlation.

(d) Positive correlation

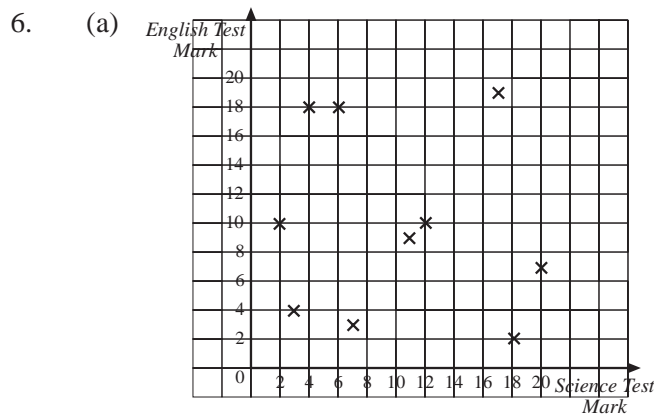

(b) No correlation

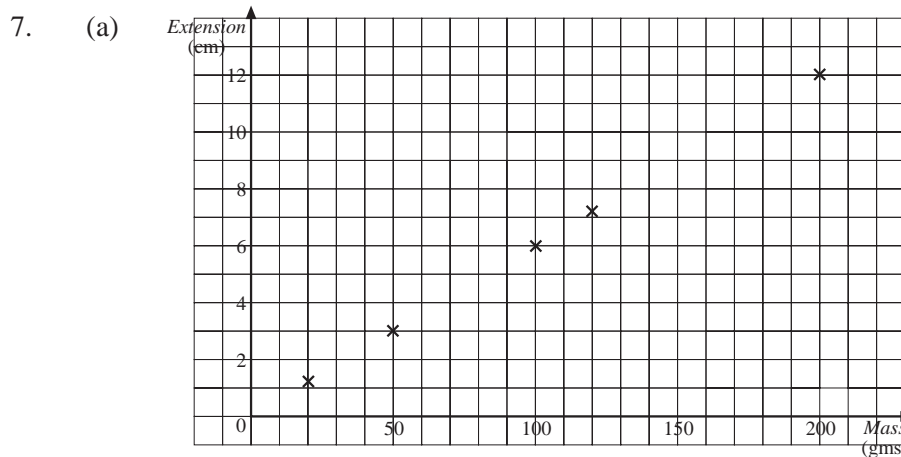

(b) Perfect positive correlation

8.3

Answers

8. (a)

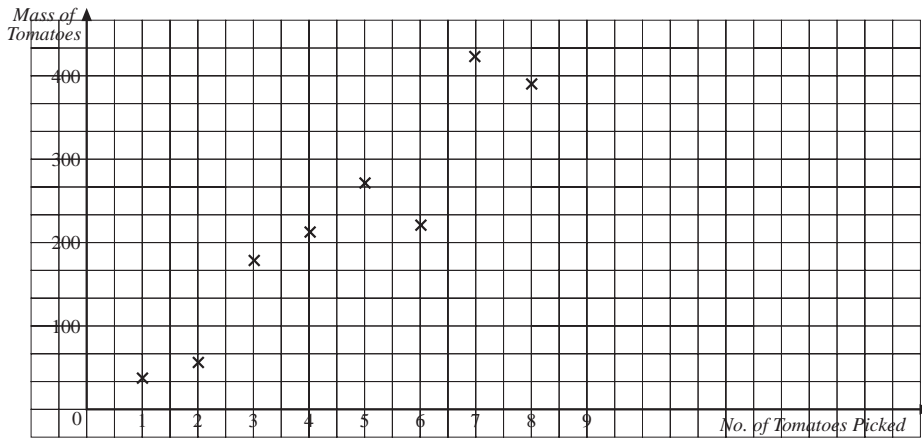

(b) Positive correlation

9. (a) Mean score $\geq 60 \Rightarrow$ total score $\geq 3 \times 60 = 180$
 \Rightarrow score in Game C $\geq 180 - 62 - 53 = 65$;

so he needs to score at least 65 in Game C.

(b)

| | | | |
|-----------------------|----|----|----|
| <i>Imran's Scores</i> | 30 | 40 | 50 |
| <i>Nia's Scores</i> | 35 | 40 | 45 |

(c) Game A and Game B – positive relationship

Game A and Game C – no relationship

(d) Game B and Game C – no relationship

8.4 Lines of Best Fit

1. (a) and (b)

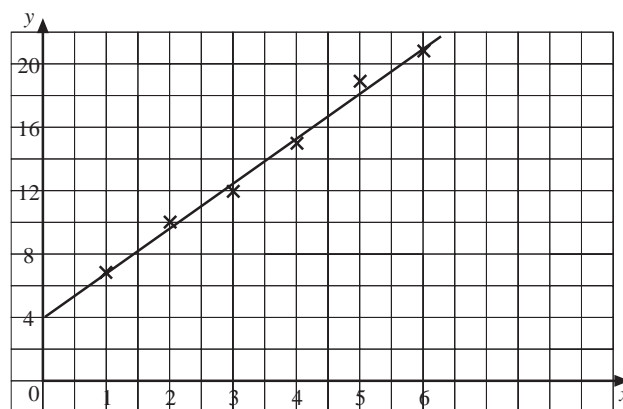

(c) $y = 4$

8.4

Answers

2. (a)

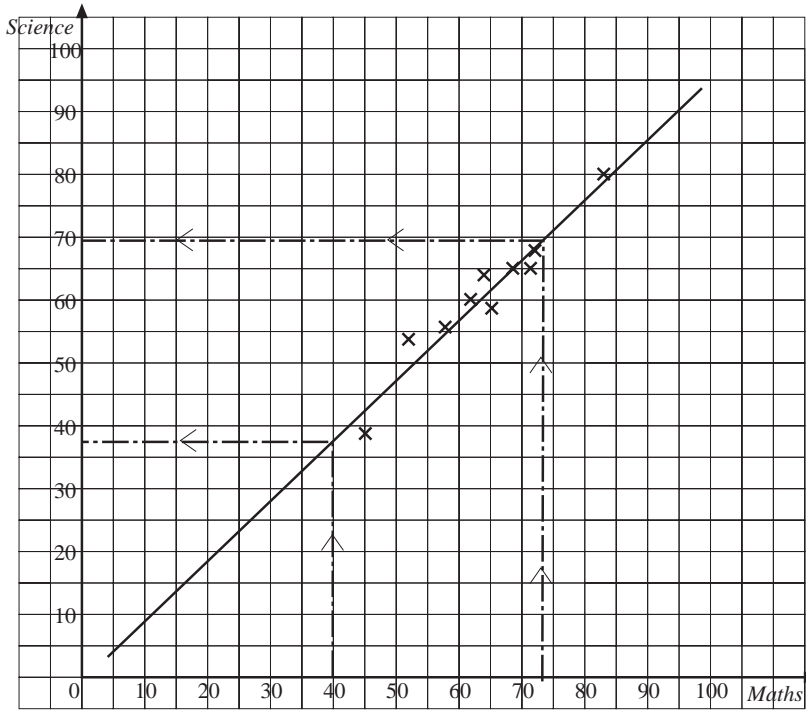

(b) (i) About 69 (ii) About 38

3. (a)

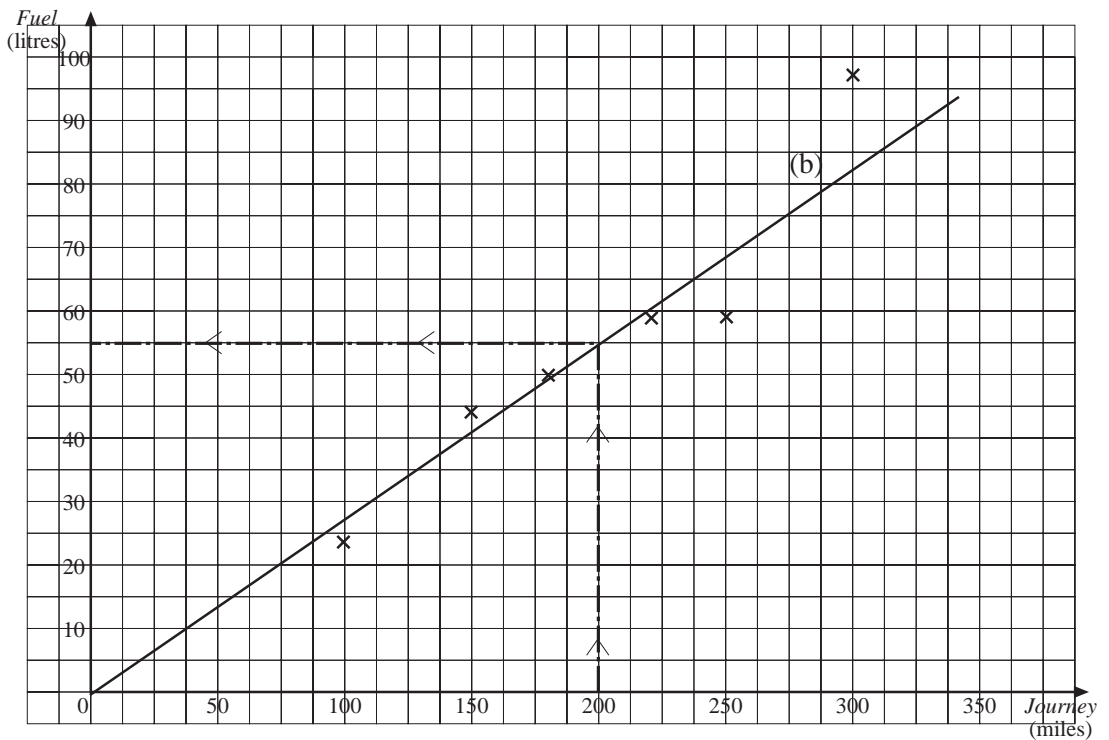

(c) About 55 litres

8.4

Answers

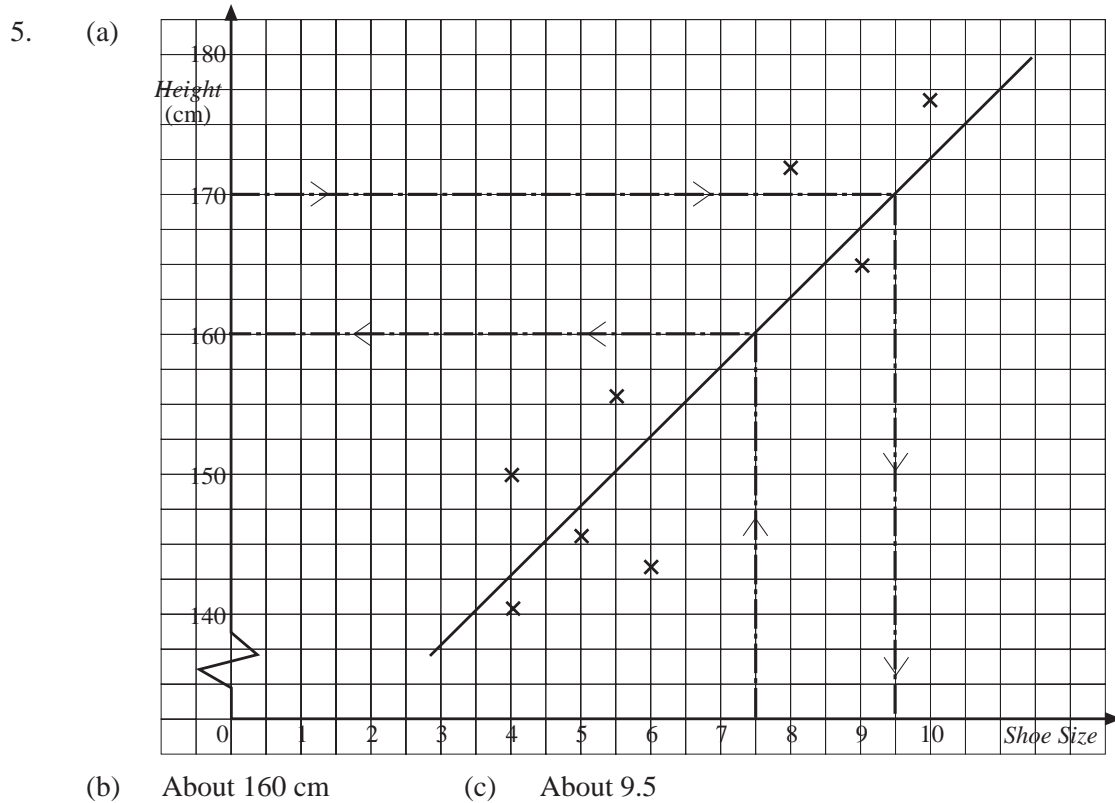
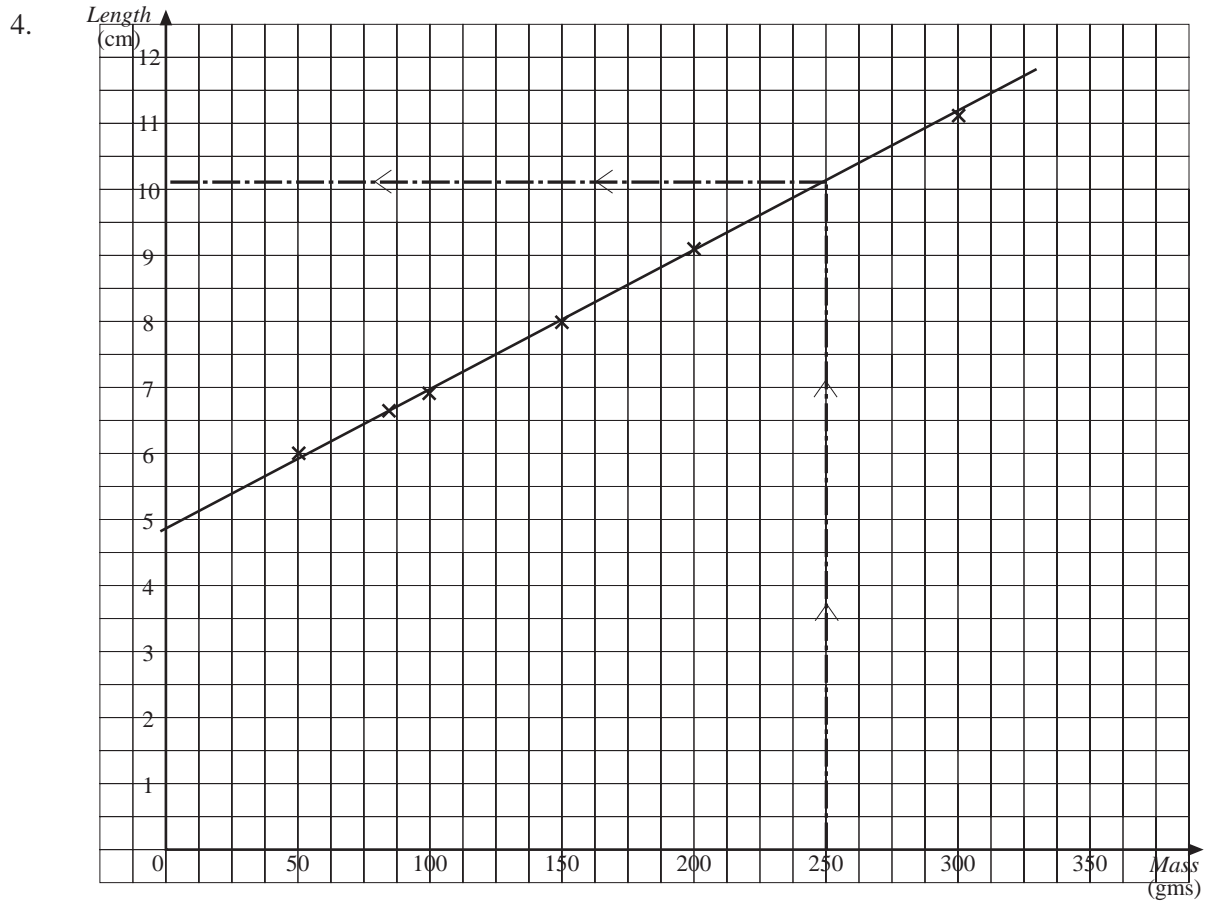

8.4

Answers

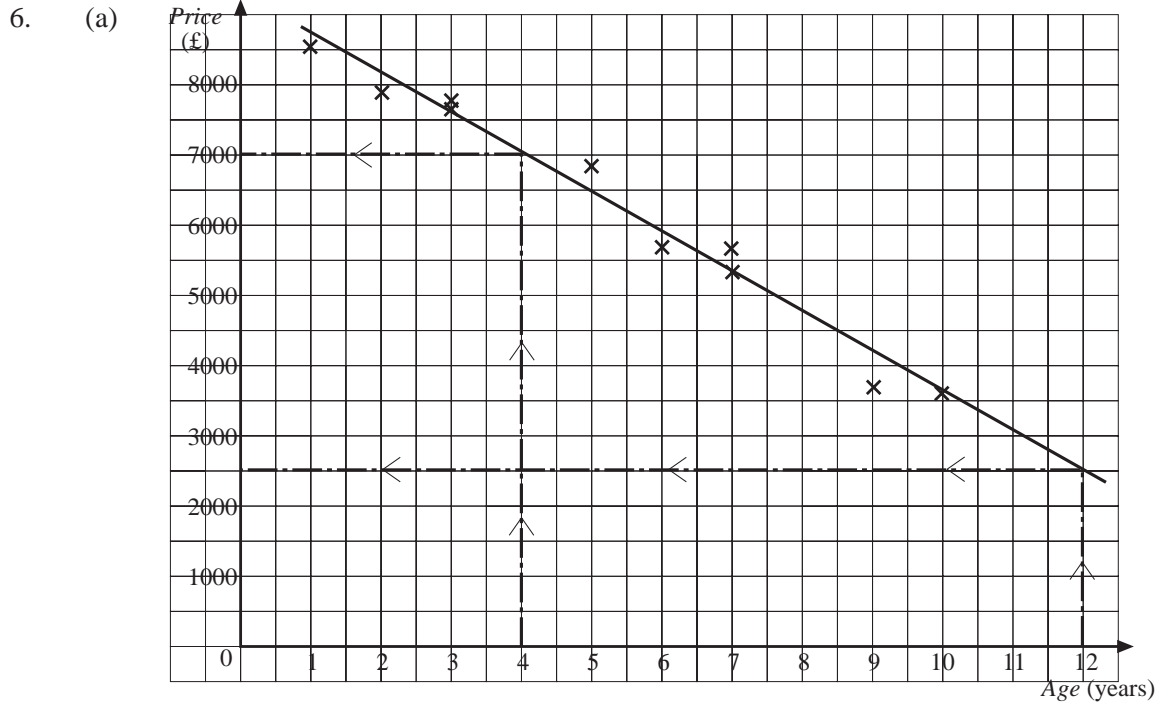

(b) About £7000 and £2500

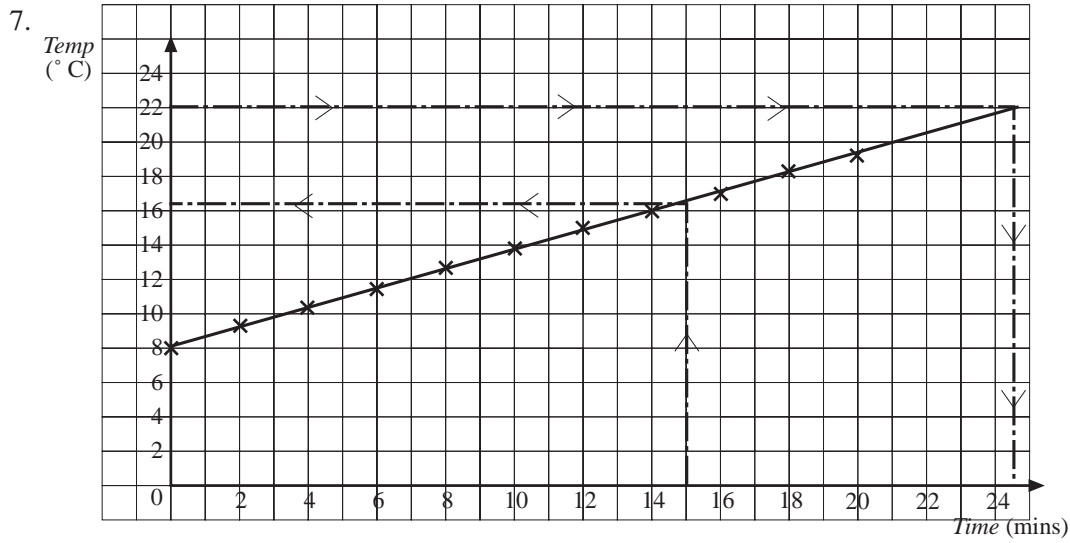

(a) About 16.5 °C

(b) About 24.5 minutes

8. See scatter plot and line of best fit opposite.

(a) About 4.9 cm

(b) About 8.5 weeks

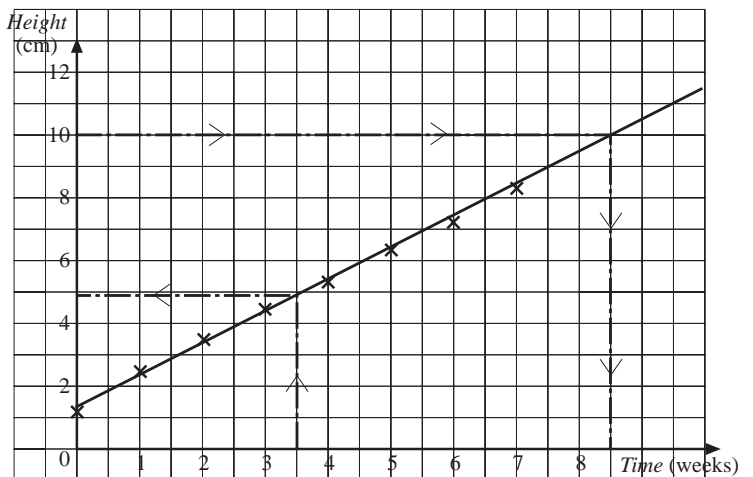

8.4

Answers

9. (a) The taller the horse, the greater its mass. (b) Approximately 590 kg
 (c) Approximately 167 cm
 (d) Scatter diagram showing evidence of positive correlation but with all the points above the line $y = x$, e.g. scatter diagram opposite
10. (a) Fewer hours worked – more time spent watching television.
 (b) Minor increase in hours slept for increased working time.
 (c) No relationship between weekly travelling distance and hours worked.
 (d) Line of best fit – about 23 hours

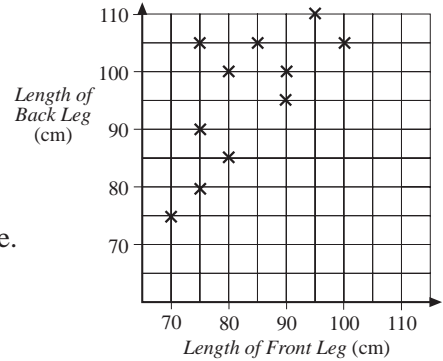

8.5 Equation of the Line of Best Fit

1. (a) $y = 0.4x + 3$ (b) $y = 0.1x + 5.2$ (c) $y = -0.2x + 6$

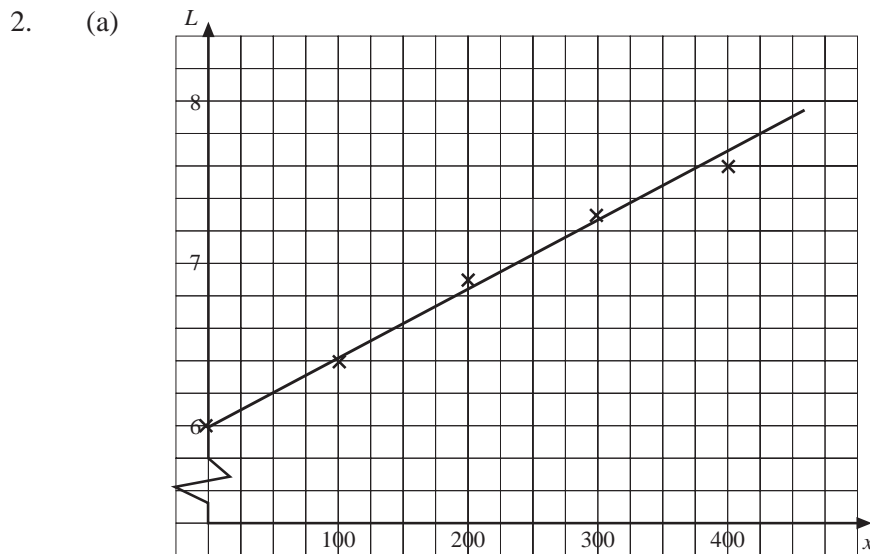

- (b) $L = 0.004x + 6$
 (c) When $x = 250$, $L = 7$; when $x = 500$, $L = 8$

The first estimate should be reliable, because it has been produced by interpolation, since $x = 250$ is within the range of the original data. The second estimate may not be as reliable, because it has been produced by extrapolation, since $x = 500$ is outside the range of the original data.

8.5

Answers

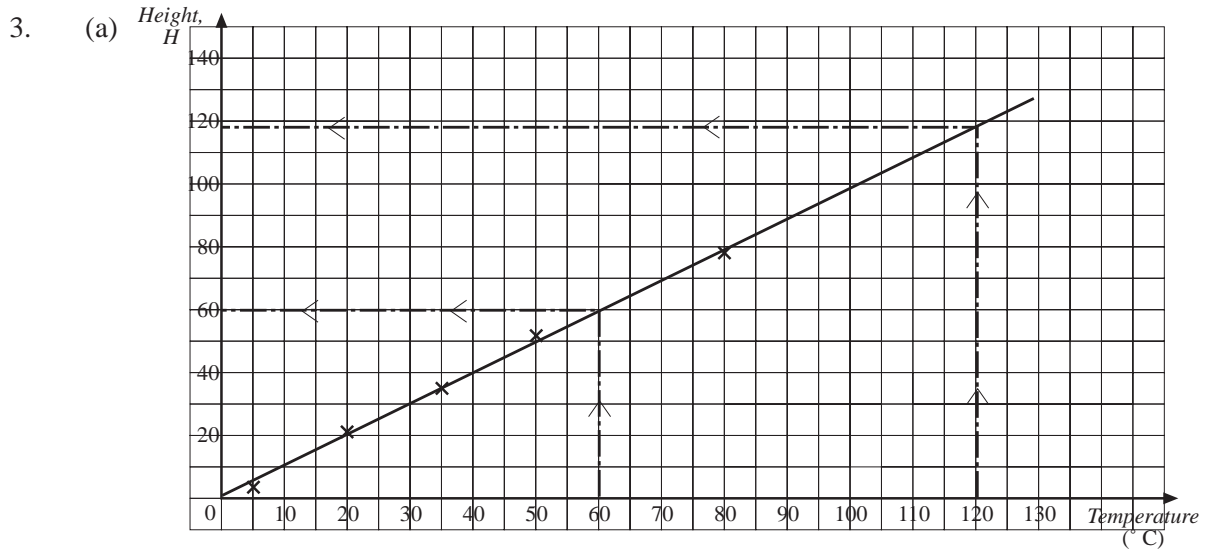

(b) $H = 0.99x + 0.6$ (c) $T = 60\text{ }^{\circ}\text{C}$; $H \approx 60\text{ cm}$. More reliable – T within range of results.

$T = 120\text{ }^{\circ}\text{C}$; $H \approx 118\text{ cm}$

4. From section 8.4, Exercises 1-8, (the equations given here are approximate)

| Question 1 | Line of Best Fit |
|------------|--------------------|
| 1 | $y = 3x + 4$ |
| 2 | $y = 0.95x + 0.22$ |
| 3 | $y = 0.3x - 6$ |
| 4 | $y = 0.02x + 5$ |
| 5 | $y = 6x + 115$ |
| 6 | $y = -550x + 9500$ |
| 7 | $y = 0.6x + 8$ |
| 8 | $y = x + 1.4$ |

5. (b)

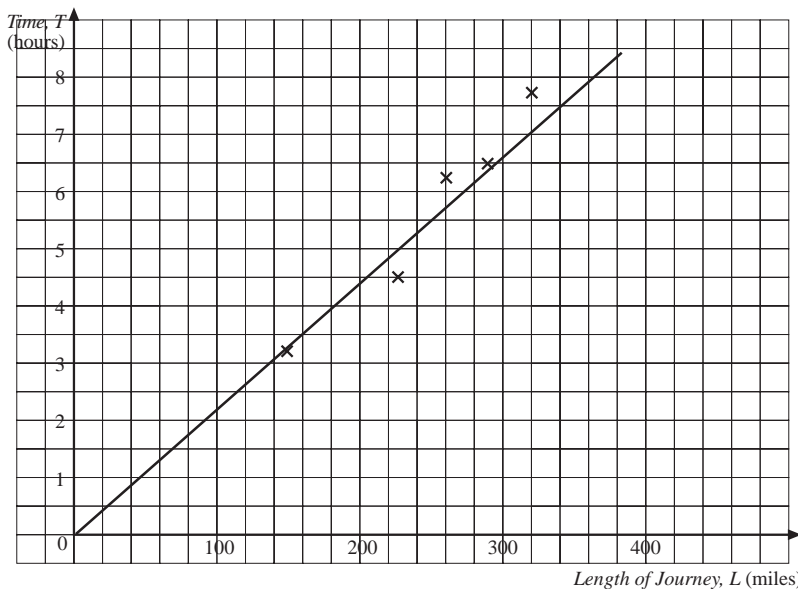

(a) The driver has not recorded the times precisely, he has given them correct to the nearest quarter of an hour.

Also, it would be more straightforward if the hours were recorded as decimals and distances to the nearest 5 miles.

(c) $T = 0.24 L$

8.5

Answers

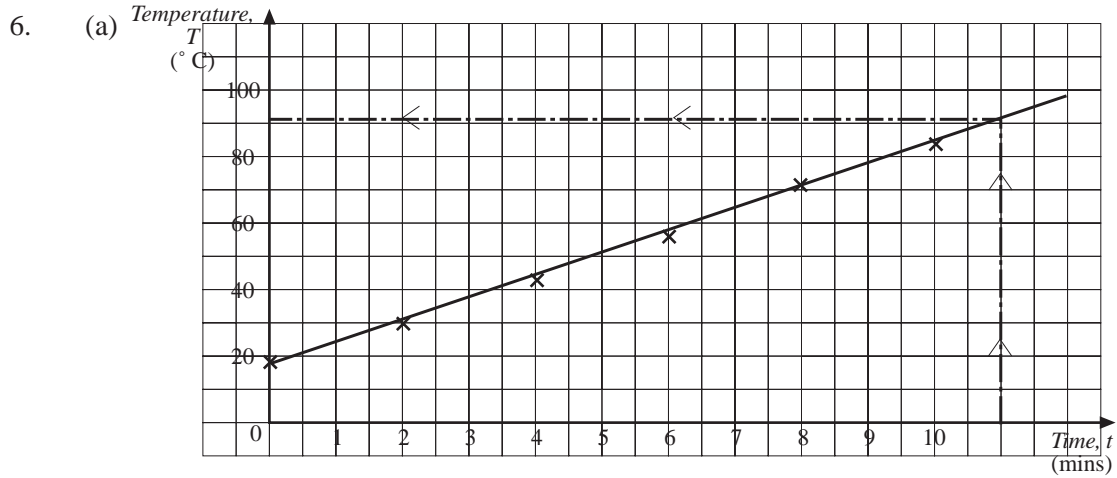

Line of best fit has equation $T = 6.7t + 18$.

- (b) After 11 minutes, temperature would be approximately 91°C .
- (c) It would be wise not to use the line of best fit to predict temperatures for later times than 11 minutes because it is beyond the range of the original data and, as the answer to part (c) shows, we are getting close to the boiling point of water, when the experimental conditions will change.

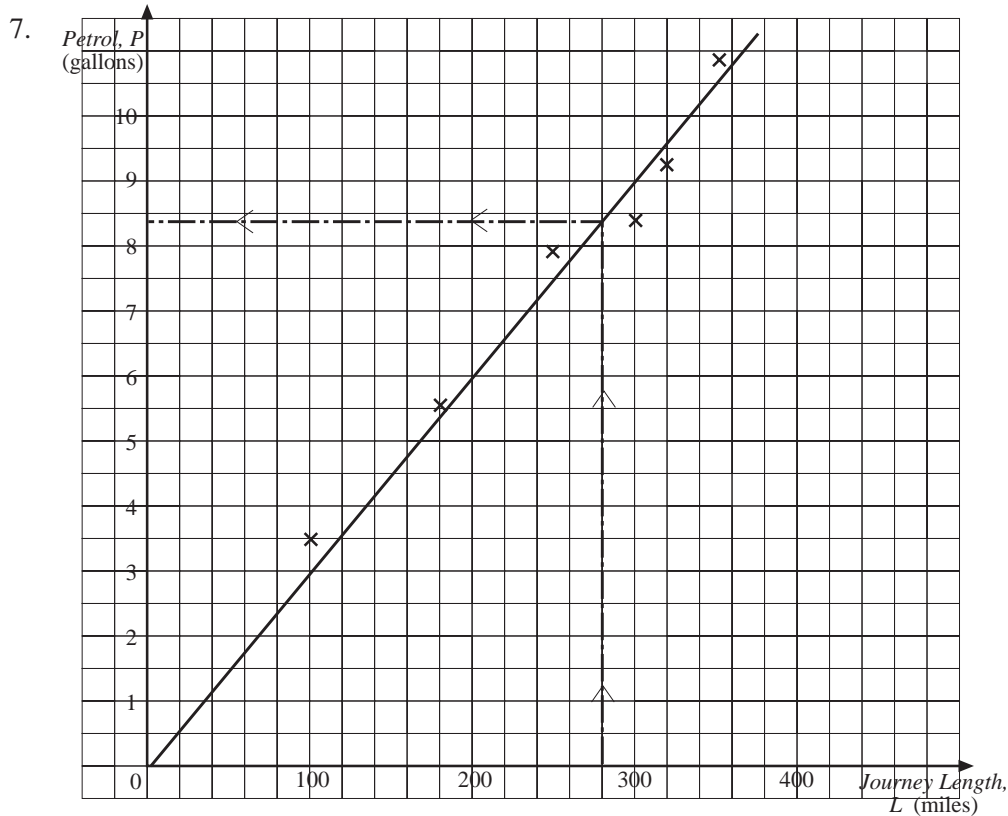

Line of best fit has equation $P = 0.03L$.

Approximately 8.4 gallons of petrol are needed for a journey of 280 miles.

8.5

Answers

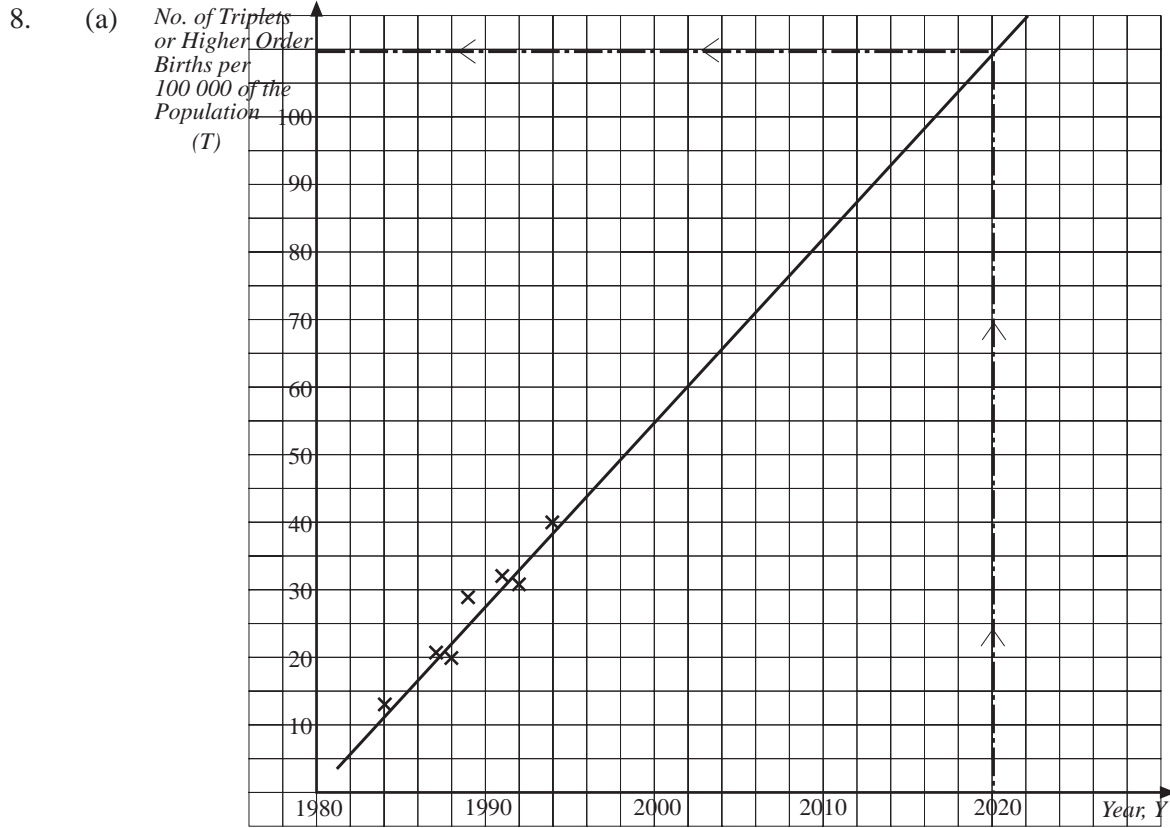

(b) Line of best fit has equation $T = 2.7Y - 5344$, when Y is the year date.

(c) The number of triplets and higher order births per 100 000 of the population in 2020 will be approximately 110.

This figure is likely to be extremely unreliable because we are extrapolating well beyond the original range of years into the future.

Practice Book *UNIT 9 Area, Perimeter and Volume* Answers

9.1 2-D Shapes

1. (a) Rectangle (b) Rhombus (c) Kite (d) Isosceles triangle
 (e) (Isosceles) trapezium (f) Equilateral triangle

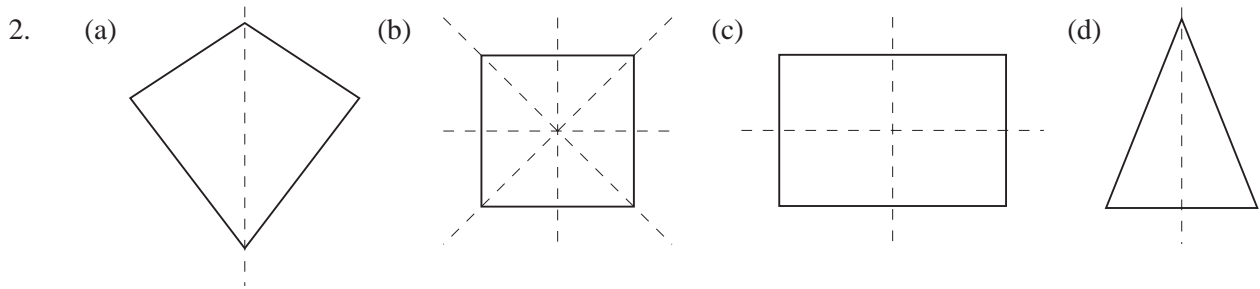

3. (a) 0 (b) 2

4. (a) True (b) True (c) False (unless the rectangle is a square)
 (d) False (e) True

5. (a) 2 (b) 4 (c) 1 (d) 3 (e) 1

6. Isosceles triangle

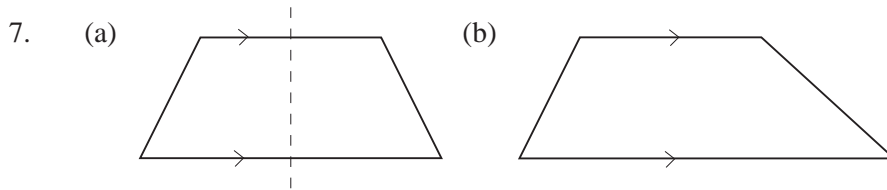

8. 45°

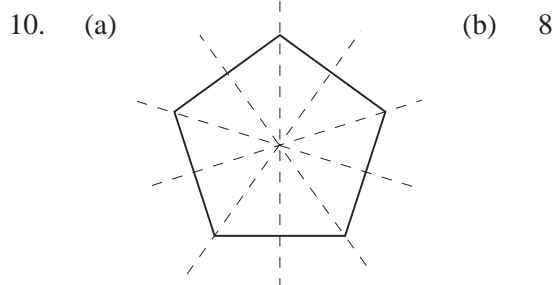
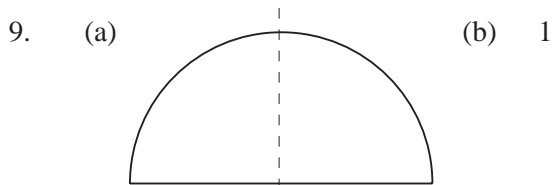

11.

| | <i>Width</i> | <i>Length</i> |
|-------------|--------------|---------------|
| Rectangle A | 3 | 5 |
| " B | 6 | 8 |
| " C | 12 | 14 |
| " D | 24 | 26 |

9.2

Answers

9.2 Area of Special Shapes

1. (a) 45 m^2 (b) 7.5 cm^2 (c) 39 m^2 (d) 12.4 cm^2
2. (a) 113 m^2 (b) 314 cm^2 (c) 63.6 cm^2
3. (a) 44 cm^2 (b) 66 cm^2 (c) 36 m^2 (d) 55 cm^2
4. (a) 1410 cm^2 (b) 77.0 mm^2
5. 33.51 cm^2
6. (a) 89.1 m^2 (b) 35.2 cm^2 (c) 208 mm^2 (d) 89.6 cm^2
7. 598.94 mm^2
8. 28.1 cm^2
9. 91 mm
10. 122.2 cm^2
11. (a) 2.5 cm (b) 10 cm
 (c) Any set of values for which $a > b$ and $(a + b) \times h = 20$, e.g. $h = 2$, $a = 6$, $b = 4$
 (d) $4x + 2 = 10x - 1 \Rightarrow 4x + 3 = 10x \Rightarrow 3 = 6x \Rightarrow x = 0.5$
 Length = $4x + 2 = 4 \times 0.5 + 2 = 4 \text{ cm}$
 Width = $\frac{\text{area}}{\text{length}} = \frac{10}{4} = 2.5 \text{ cm}$
12. (a) Area first semicircle = $\pi \times (3a)^2 \div 2 = 4.5\pi a^2$
 Area second semicircle = $\pi \times (2a)^2 \div 2 = 2\pi a^2$
 Area third semicircle = $\pi \times (a)^2 \div 2 = 0.5\pi a^2$
 Total area = first semicircle + second semicircle - third semicircle
 = $4.5\pi a^2 + 2\pi a^2 - 0.5\pi a^2 = 6\pi a^2$
- (b) $6\pi a^2 = 12 \quad \therefore a^2 = \frac{2}{\pi} \quad \therefore a = \sqrt{\frac{2}{\pi}}$
13. (Height of triangle) $^2 = 25^2 - 7^2 = 625 - 49 = 576$
 \therefore height of triangle = $\sqrt{576} = 24 \text{ cm}$
 \therefore area of triangle = $7 \times 24 \div 2 = 84 \text{ cm}^2$

9.2

Answers

14. (a) Area of one triangle = $5 \times 4 \div 2 = 10 \text{ cm}^2$
 \therefore area of hexagon = $6 \times 10 = 60 \text{ cm}^2$
- (b) Volume of box = area of cross-section \times length = $60 \times 10 = 600 \text{ cm}^3$
 \therefore volume of coffee = 80% of $600 \text{ cm}^3 = 0.8 \times 600 = 480 \text{ cm}^3$
 \therefore mass of coffee = $0.5 \times 480 = 240$ grams
- (c) The cost of 100 grams = $\pounds 2.19 \div 227 \times 100$
 $= 0.964757709 = \pounds 0.96$ (to the nearest penny)

9.3 Perimeter of Special Shapes

1. (a) 37.7 m (b) 47.1 cm (c) 50.3 mm
2. (a) 24 cm (b) 27 cm (c) 29 cm (d) 18 cm
3. 46.3 cm
4. (a) 50.27 cm (b) 28.57 cm
5. (a) 28.6 cm (b) 20.3 cm (c) 61.4 m (d) 45.7 cm
6. (a) 34 cm (b) 30 cm
7. 24 m
8. 30.28 m
9. 89.1 cm
10. 7.2 cm
11. (a) $p = 3a$ (b) $p = 3b + 2c$
 (c) $p = 2d + 7$ (d) $p = 4e + 4f + 8$
12. (a) 22 cm

- (b) The diagram opposite shows the 4 possible arrangements, ignoring rotations and reflections, with perimeter 18 or 20 cm.
- (c) The arrangement of the tiles is more compact than the original design, with the tiles sharing as many common sides as possible.

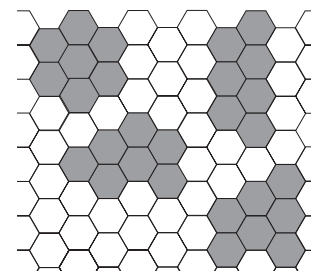

9.3

Answers

- (d) The diagram opposite shows 4 of the possible arrangements, ignoring rotations and reflections, that have perimeter 30 cm.
- (e) The arrangement of the tiles is designed to be as spread out as possible, with the tiles sharing as few common sides as possible.
13. (a) Distance moved = wheel circumference = $\pi \times 60$
 $= 188.4955592 \text{ cm} = 188.5 \text{ cm}$ (to one decimal place)
- (b) Wheel circumference = $\pi \times 52 = 163.362818 \text{ cm}$
 Number of turns = $950 \div 163.362818 = 5.815276767$
 $= 5.82 \text{ turns}$ (to 3 s.f.) or 5 complete turns
14. (a) Area = $\pi \times 15^2 = 706.8583471 \text{ cm}^2 = 707 \text{ cm}^2$ (to 3 s.f.)
 (b) Radius = $120 \div (2 \times \pi) = 19.09859317 \text{ cm} = 19.1 \text{ cm}$ (to 3 s.f.)

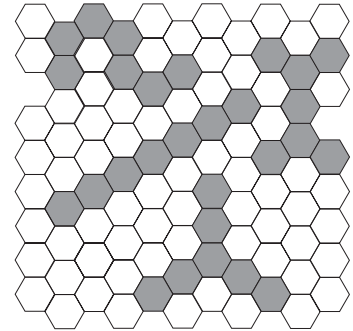

9.4 Surface Area and Volume of 3-D Shapes

1. (a) Volume = 96 cm^3 Surface area = 152 cm^2
 (b) Volume = 140 m^3 Surface area = 166 m^2
2. (a) Volume = 1610 cm^3 Surface area = 804 cm^2
 (b) Volume = 503 cm^3 Surface area = 352 cm^2
3. (a) Volume = 105 cm^3 (b) Volume = 36 m^3
4. Volume = 15 m^3 Surface area = 63 m^2
5. Volume = 125.15 cm^3
6. Total volume = $1.102654825 \text{ m}^3 = 1.1 \text{ m}^3$ (to 2 significant figures)
7. (a) Volume = $6250\pi = 19634.95409 \text{ cm}^3 = 19600 \text{ cm}^3$ (to 3 s.f.)
 (b) Total surface area = $2750\pi = 8639.379797 \text{ cm}^2 = 8640 \text{ cm}^2$ (to 3 s.f.)
8. (a) Volume = $300 + 62.5\pi = 496.3495409 \text{ cm}^3 = 496 \text{ cm}^3$ (to the nearest cm^3)
 (b) Total surface area = $250 + 56.25\pi = 426.7145868 \text{ cm}^2 = 427 \text{ cm}^2$ (to the nearest cm^2)
9. (a) 12 mm (b) 516 mm^2
10. (a) Height = 11 cm
 (b) Volume = $396\pi = 1244.070691 \text{ cm}^3 = 1244 \text{ cm}^3$ (to the nearest cm^3)

9.4

Answers

11. (a) (i) 12 (ii) 10 (iii) 16 (iv) 30
 (b) 24
12. (a) 300 cm^3 (b) 360 cm^3 (c) 12 pots
13. (a) $6^2 + 8^2 = 36 + 64 = 100 = 10^2$, so angle x° must be a right angle by Pythagoras' Theorem.
- (b) Area of cross-section $= \frac{1}{2} \times \text{base} \times \text{height} = \frac{1}{2} \times 6 \times 8 = 24 \text{ cm}^2$
 \therefore volume of prism $= \text{area of cross-section} \times \text{length} = 24 \times 7 = 168 \text{ cm}^3$
- (c)
- | | <i>Prism A</i> | <i>Prism B</i> |
|--------|--------------------|--------------------|
| height | 5 cm | 3 cm |
| volume | 200 cm^3 | 120 cm^3 |
14. (a) 175 cm^3
- (b) Length of label $= 134 \div 5 = 26.8 \text{ cm}$
 \therefore distance around tin $= 26.8 - 1 = 25.8 \text{ cm}$
- (c) Volume $= \pi r^2 h = \pi \times 3^2 \times 4 = 36\pi = 113.0973355 \text{ cm}^3$
 $= 113 \text{ cm}^3$ (to 3 s.f.)

Practice Book *UNIT 10 Sequences*

Answers

10.1 Constant Differences

1. (a) 17, 20, 23 (b) 54, 63, 72 (c) 18, 19, 20 (d) 47, 55, 63
2. (a) 90, 88, 86 (b) 5, 2, -1 (c) 23, 18, 13 (d) -3, -7, -11
3. (a) 4, 10, 16, 22, 28 (b) 6
4. (a) 10, 18, 26, 34, 42 (b) 8 (c) 50, 58, 66
5. (a) 4, 11, 18, 25 (b) 7
(c) The first difference 7 is the multiple of n in the formula $u_n = 7n - 3$.
6. (a) 11, 20, 29, 38
(b) The first difference 9 is the multiple of n in the formula $u_n = 9n + 2$.
7. (a) 11 (b) 4, 15, 26, 37 (c) 103
8. (a) 78, 74, 70, 66, 62 (b) -4
(c) The first difference -4 is the multiple of n in the formula $u_n = 82 - 4n$.
(d) 2
9. (a) 795 (b) 272 (c) 622 (d) 710
10. (a) B and C (b) D (c) B (d) C
11. (a) -3 and 13 The numbers on this line go up in steps of 4.
(b) 7.9, 8.0, 8.1 The numbers on this line go up in steps of 0.1.
12. (a) $3N$ represents the number of grey tiles in pattern N .
(b) 1 black and 36 grey tiles (c) Pattern 20 (d) number of tiles = $1 + 6N$
(e) Any suitable pattern with first three diagrams having 5, 9 and 13 tiles,
e.g.

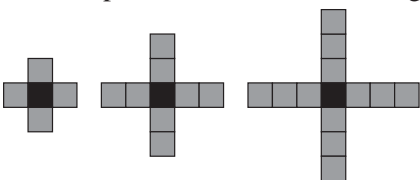
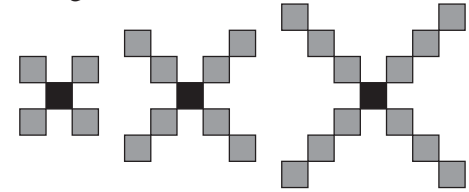

13. (a) 4 (b) 24 (c) 36 (d) 10

10.2 Finding the Formula for a Linear Sequence

1. (a) 4 (b) $u_n = 4n + 3$
2. (a) $u_n = 4n + 2$ (b) $u_n = 2n + 9$ (c) $u_n = 7n + 2$
(d) $u_n = 22n + 12$ (e) $u_n = 9n + 13$
3. (a) 16 (b) 5 (c) $u_n = 5n - 4$

10.2

Answers

4. (a) $u_n = 3n - 2$ (b) $u_n = 4n - 2$ (c) $u_n = 9n - 5$
 (d) $u_n = 10n - 5$ (e) $u_n = 19n - 18$
5. (a) -2 (b) $u_n = 20 - 2n$
6. (a) $u_n = 22 - 3n$ (b) $u_n = 104 - 4n$ (c) $u_n = 48 - 7n$
 (d) $u_n = 82 - 16n$ (e) $u_n = 99 - 9n$
7. (a) -2 (b) $u_n = -2n$
8. (a) $u_n = 5 - 5n$ (b) $u_n = 2n - 20$ (c) $u_n = -2 - 3n$
 (d) $u_n = 15 - 7n$ (e) $u_n = 4n - 11$
9. (a) $u_n = 31n - 11$ (b) 20, 51, 82, 113, 144
10. (a) $u_n = 11n - 6$ (b) 5, 16, 27, 38, 49

11. (a)

| pattern number | number of <i>grey</i> tiles | number of <i>white</i> tiles |
|----------------|-----------------------------|------------------------------|
| 5 | 6 | 10 |
| 16 | 17 | 32 |

(b)

| pattern number | number of <i>grey</i> tiles | number of <i>white</i> tiles |
|----------------|-----------------------------|------------------------------|
| n | $n + 1$ | $2n$ |

- (c) Total number of tiles = $(n + 1) + 2n = 3n + 1$
- (d) The number of grey tiles follows the sequence 4, 6, 8, 10, ... with constant first difference 2, and n th term $2n + 2$. The number of white tiles follows the sequence 5, 8, 11, 14 ... with constant first difference 3, and n th term $3n + 2$.
- \therefore total number of tiles = number of grey tiles + number of white tiles
 $= (2n + 2) + (3n + 2) = 5n + 4$

10.3 Second Differences and Quadratic Sequences

1. (a) 4, 9, 16, 25, 36, 49 (b) The second differences are all 2. (c) 64, 81
2. (a) 16 (b) 6, 29, 68, 123, 194
 (c) The second differences are all 16, as expected.
3. (a) The second differences are all 2. (b) $u_n = n^2 + 5$
4. (a) $u_n = 2n^2 - 1$ (b) $u_n = 4n^2 + 2$
 (c) $u_n = 5n^2 - 10$ (d) $u_n = 3n^2 - 2$
5. (a) The second differences are all 4. (b) 0, 1, 2, 3, 4, 5
 (c) Simpler sequence = $n - 1$ (d) $u_n = 2n^2 + n - 1$

10.3

Answers

6. (a) The second differences are all 8. (b) $u_n = 4n^2 - n + 3$
7. (a) $u_n = 4n^2 + 2n - 3$ (b) $u_n = 3n^2 + 4n - 2$
 (c) $u_n = 4n^2 + 2n + 3$ (d) $u_n = 5n^2 + n - 10$
8. (a) The second differences are all -4 . (b) $u_n = -2n^2 + n + 10$
 (c) 20th term = $-2 \times 20^2 + 20 + 10 = -800 + 30 = -770$
9. $u_n = -n^2 + 7n$
10. (a) The first differences are 7, 19, 37, 61, 91.
 The second differences are 12, 18, 24, 30.
 The third differences are all 6.
 (b) $u_n = n^3 + 5$
11. (a) 4 black tiles and 64 grey tiles (b) 4 black tiles and 256 grey tiles
 (c) 4 black tiles and P^2 grey tiles (d) $T = P^2 + 4$

10.4 Special Sequences

1. (a) 29, 47, 76 (b) 57, 92, 149 (c) $\frac{6}{17}, \frac{7}{20}, \frac{8}{23}$
 (d) 1215, 3645, 10 935
2. (a) 0, 3, 3, 6, 9, 15 (b) 3, 4, 11, 26, 63, 152
 (c) 6, 10, 24, 62, 162, 424 (d) 1, 2, 2, 4, 8, 32
3. (a) 1024, 4096, 16 384 (b) $u_n = 4^{n-1}$ or $u_n = \frac{1}{4} \times 4^n$
4. (a) $u_n = 3 \times 5^n$ (b) $u_n = 3^{n-1}$ or $u_n = \frac{1}{3} \times 3^n$
 (c) $u_n = 2 \times 10^n$ (d) $u_n = 4 \times 7^{n-1}$ or $\frac{4}{7} \times 7^n$
5. (a) $u_n = 6n - 5$ (b) $u_n = 8n - 6$ (c) $u_n = \frac{6n - 5}{8n - 6}$
6. (a) $u_n = \frac{n}{n + 3}$ (b) $u_n = \frac{2n - 1}{8n - 5}$ (c) $u_n = \frac{9n - 4}{5n + 2}$
 (d) $u_n = \frac{6n - 5}{5 \times 2^n}$

10.4

Answers

7. (a) $u_n = \frac{3n}{4n-1}$ 10th term = $\frac{30}{39} = \frac{10}{13}$

(b) $u_n = \frac{5n-4}{3n+2}$ 10th term = $\frac{46}{32} = \frac{23}{16}$

8. (a)

| n | u_n | u_n to 3 decimal places |
|------|----------------------|---------------------------|
| 1 | 1 | 1.000 |
| 5 | $1\frac{2}{3}$ | 1.667 |
| 10 | $1\frac{9}{11}$ | 1.818 |
| 50 | $1\frac{49}{51}$ | 1.961 |
| 100 | $1\frac{99}{101}$ | 1.980 |
| 500 | $1\frac{499}{501}$ | 1.996 |
| 1000 | $1\frac{999}{1001}$ | 1.998 |
| 2000 | $1\frac{1999}{2001}$ | 1.999 |

(b) As n becomes larger and larger, u_n gets closer and closer to 2.

9. (a)

| n | u_n to 3 decimal places |
|------|---------------------------|
| 1 | 4.000 |
| 5 | 4.800 |
| 10 | 4.900 |
| 50 | 4.980 |
| 100 | 4.990 |
| 500 | 4.998 |
| 1000 | 4.999 |
| 2000 | 5.000 |

As n becomes larger and larger, u_n gets closer and closer to 5.

(b)

| n | u_n to 3 decimal places |
|------|---------------------------|
| 1 | 7.000 |
| 5 | 6.200 |
| 10 | 6.100 |
| 50 | 6.020 |
| 100 | 6.010 |
| 500 | 6.002 |
| 1000 | 6.001 |
| 2000 | 6.001 |

As n becomes larger and larger, u_n gets closer and closer to 6.

10.4

Answers

(c)

| n | u_n to 3 decimal places |
|------|---------------------------|
| 1 | 2.000 |
| 5 | 2.667 |
| 10 | 2.818 |
| 50 | 2.961 |
| 100 | 2.980 |
| 500 | 2.996 |
| 1000 | 2.998 |
| 2000 | 2.999 |

As n becomes larger and larger, u_n gets closer and closer to 3.

(d)

| n | u_n to 3 decimal places |
|------|---------------------------|
| 1 | 1.000 |
| 5 | 0.600 |
| 10 | 0.550 |
| 50 | 0.510 |
| 100 | 0.505 |
| 500 | 0.501 |
| 1000 | 0.501 |
| 2000 | 0.500 |

As n becomes larger and larger, u_n gets closer and closer to $\frac{1}{2}$.

10. (a) $u_n \rightarrow 4$ as n increases (b) $u_n \rightarrow 7$ as n increases
 (c) $u_n \rightarrow 0.5$ as n increases (d) $u_n \rightarrow 2$ as n increases

11. (a) Multiply by 2 each time.

(b) For example,

$$1 \rightarrow 5 \rightarrow 9 \rightarrow 13 \rightarrow 17 \quad +4 \text{ each time}$$

$$1 \rightarrow 5 \rightarrow 25 \rightarrow 125 \rightarrow 625 \quad \times 5 \text{ each time}$$

$$1 \rightarrow 5 \rightarrow 13 \rightarrow 29 \rightarrow 61 \quad \times 2 + 3 \text{ each time}$$

(There are *many* alternatives.)

12. (a) $u_n = \frac{n}{2n+1}$ (b) Graph 2 (c) $\frac{2}{5}, \frac{3}{10}, \frac{4}{17}$ (d) Graph 1

Practice Book *UNIT 11 Algebraic Manipulation* **Answers**

11.1 Equations, Formulae and Identities

1. (a) $x = 3$ (b) $x = 13$ (c) $x = 6$ (d) $x = 5$ (e) $x = 12$
 (f) $x = 14$ (g) $x = 15$ (h) $x = 6$ (i) $x = 36$
2. (a) $x = 5$ (b) $x = 6$ (c) $x = 2$ (d) $x = 7$ (e) $x = 9$
 (f) $x = 4$ (g) $x = 2$ (h) $x = 77$ (i) $x = 16$ (j) $x = -1$
 (k) $x = -2\frac{1}{2}$ (l) $x = -20$
3. (a) $C = 25$ (b) $C = 20$ (c) $C = 70$
4. (a) $v = 23$ (b) $v = 7.2$ (c) $v = 118$ (d) $v = -4.4$
5. (a) $A = 42$ (b) $A = 78$ (c) $A = 9.6$ (d) $A = 23.4$
6. (a) 11.5 (b) 43 (c) 34.5 (d) 15 (e) -12
 (f) 92.25 (g) 40 (h) 30 (i) 57
7. (a) $y = 7$ (b) $x = 7$ (c) $x = 3.25$
8. (a) $m = 9$ (b) $x = 2$ (c) $z = 15$
9. (a) $F = 212$ (b) $F = 140$ (c) $F = 32$
10. A and D
11. (a) $n + 2$ (b) $n - 1$ (c) $2n$
 (d) No, Jacob is not holding the same number of cubes in each hand.
 $2n - 1 = n + (n - 1)$, so he has one more cube in the hand with $2n - 1$ than in the hand with $2(n - 1)$.
12. (a) $n + 5$ (b) $t - 2$ (c) B, D and E
13. (a) $m + 2n + p$

(b)

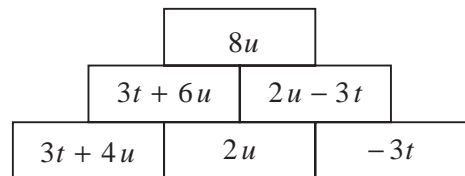
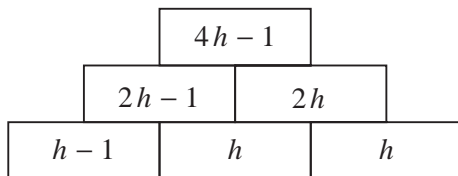

- (c) The top brick contains $2h + 2j + 2k = 2(h + j + k)$ which, being a double, is bound to be an even number as h, j and k are integers.

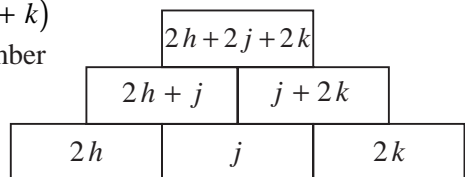

11.2

Answers

11.2 Simplifying Expressions

1. (a) $6a + b$ (b) $10b + 5c$ (c) $3a + 7b$ (d) $6p + 14q$
 (e) $14x + 5y$ (f) $11x + 6y + 7z$ (g) $13x - 12y$ (h) $3y + 16z$
2. (a) $2x^2 + 7x$ (b) $2y^2 + 7y$ (c) $4a^2 - a$ (d) $-3x^2 + 15x$
3. (a) $3x + 18$ (b) $4x + 8$ (c) $3x - 3$
 (d) $8x + 20$ (e) $18x - 30$ (f) $14x - 35$
 (g) $24 - 12x$ (h) $24 - 40x$ (i) $45x + 90$
4. (a) $6x + 22$ (b) $7x - 24$ (c) $10x + 31$
 (d) $39x - 10$ (e) $4x - 20$ (f) $3x$
5. (a) $x^2 + 3x$ (b) $6x^2 + x$ (c) $3x^2 - 2x$
 (d) $8x - 2x^2$ (e) $12x^2 + 24x$ (f) $15x^2 - 35x$
 (g) $11x^2 - 33x$ (h) $28x + 42x^2$ (i) $24x - 12x^2$
6. (a) $x^2 + 7x + 12$ (b) $x^2 + 6x + 8$ (c) $x^2 + 6x + 5$
 (d) $x^2 + 5x - 6$ (e) $x^2 - 2x - 8$ (f) $x^2 - x - 6$
 (g) $x^2 - 9x + 20$ (h) $x^2 - 5x + 6$ (i) $x^2 - 16x + 63$
7. (a) $2x^2 + 9x + 10$ (b) $2x^2 + 14x + 16$ (c) $7x + 18$
 (d) $-2x + 23$
8. (a) $6x^2 + 7x + 2$ (b) $8x^2 - 10x - 7$ (c) $6x^2 - 14x - 40$
 (d) $12x^2 - 17x - 40$ (e) $24x^2 - 18x - 6$ (f) $18x^2 - 57x + 35$
9. (a) $27x^2 + 11x + 28$ (b) $14x^2 + 23x + 3$ (c) $-10x + 30$
10. (a) $x^2 + 2x + 1$ (b) $x^2 - 4x + 4$ (c) $x^2 + 6x + 9$
 (d) $x^2 + 10x + 25$ (e) $x^2 - 14x + 49$ (f) $x^2 - 16x + 64$
 (g) $x^2 + 20x + 100$ (h) $x^2 - 24x + 144$ (i) $x^2 + 8x + 16$
 (j) $4x^2 + 12x + 9$ (k) $16x^2 - 56x + 49$ (l) $9x^2 + 12x + 4$
 (m) $16x^2 + 8x + 1$ (n) $25x^2 - 20x + 4$ (o) $36x^2 - 48x + 16$
11. (a) $x^2 - 1$ (b) $x^2 - 9$ (c) $x^2 - 49$ (d) $x^2 - 81$
 (e) $x^2 - 144$ (f) $4x^2 - 1$ (g) $9x^2 - 4$ (h) $16x^2 - 49$
12. (a) $x^3 + 3x^2 + 3x + 1$ (b) $8x^3 + 12x^2 + 6x + 1$ (c) $x^3 - 15x^2 + 75x - 125$

11.2

Answers

13. (a) $n \div 2$ (b) n^2 (c) $n + n$ and $2n$

(d) $5n$ or $n + n + n + n + n$ etc.

14. (a) (i) Area of rectangle A = 100 cm^2
 Area of rectangle B = 80 cm^2
 Area of rectangle C = 40 cm^2
 Area of rectangle D = 32 cm^2
 (ii) Total area = 252 cm^2 (iii) 252

(b) (i) Area of rectangle E = $n^2 \text{ cm}^2$
 Area of rectangle F = $3n \text{ cm}^2$
 Area of rectangle G = $2n \text{ cm}^2$
 Area of rectangle H = 6 cm^2
 (ii) $n^2 + 5n + 6$

15. (a) $9x - 14$ (b) $x^2 + 5x + 6$
 (c) $x^2 + 3x - 4$ (d) $x^2 - 4x + 4$

16. (a) $n^2 - 1$ (b) 82

| | |
|--------------------------|----------------|
| first number in row n | $n^2 - 2n + 2$ |
| second number in row n | $n^2 - 2n + 3$ |

| | |
|------------------------------|---------------------------|
| centre number in row n | $n^2 - n + 1$ |
| centre number in row $n + 1$ | $(n + 1)^2 - (n + 1) + 1$ |

(e) $(n + 1)^2 - (n + 1) + 1 = (n^2 + 2n + 1) - (n + 1) + 1$
 $= n^2 + 2n + 1 - n - 1 + 1$
 $= n^2 + n + 1$

11.3

Answers

11.3 Factorising

1. (a) $2(2x - 1)$ (b) $6(x - 2)$ (c) $5(x - 4)$
(d) $4(x + 8)$ (e) $2(3x - 4)$ (f) $4(2 - 3x)$
(g) $7(3x - 2)$ (h) $5(3x + 4)$ (i) $10(3 - x)$
2. (a) $x(x + 4)$ (b) $x(x - 3)$ (c) $x(4 - x)$
(d) $2x(3x + 4)$ (e) $3x(3x + 5)$ (f) $7x(x - 3)$
(g) $7x(4 - 5x)$ (h) $2x(3x - 7)$ (i) $x(5x - 3)$
3. (a) $x^2(x + 1)$ (b) $x^2(2 - x)$ (c) $2x^2(2x - 1)$
(d) $4x^2(2x + 1)$ (e) $4x^2(4 - 9x)$ (f) $2x^2(2x + 11)$
(g) $2x^2(8 - 3x)$ (h) $7x^2(2x + 3)$ (i) $7x^2(4x - 7)$
4. (a) $x^2 - 25$ (b) $(x + 5)(x - 5)$
(c) (i) $(x + 7)(x - 7)$ (ii) $(x + 8)(x - 8)$ (iii) $(x + 10)(x - 10)$
(iv) $(x + a)(x - a)$ (v) $(x + 2b)(x - 2b)$
5. (a) $(x + 3)(x + 4)$ (b) $(x + 1)(x + 7)$ (c) $(x + 2)(x + 9)$
(d) $(x + 3)(x + 9)$ (e) $(x + 7)(x + 10)$ (f) $(x + 2)(x + 4)$
(g) $(x + 2)(x + 14)$ (h) $(x + 7)(x + 11)$ (i) $(x + 7)(x + 9)$
6. (a) $(x + 2)(x - 1)$ (b) $(x + 5)(x - 4)$ (c) $(x + 3)(x - 4)$
(d) $(x - 4)(x - 9)$ (e) $(x - 2)(x - 8)$ (f) $(x + 7)(x - 6)$
(g) $(x + 15)(x - 2)$ (h) $(x - 8)(x - 9)$ (i) $(x + 9)(x - 11)$
7. $a = x - 5$
8. $a = x + 5$
9. $h = x + 5$
10. $a = 10$

11.4

Answers

11.4 Using Formulae

1. (a) 4 (b) 11 (c) 14 (d) 29
 (e) -6 (f) 37 (g) 0 (h) 2
 (i) 14 (j) -24 (k) -44 (l) -41
2. (a) $p = x + (x + 1) + (x + 2) + (x + 2) = 4x + 5$ (b) $p = 61$ (c) $x = 17$
3. (a) $p = x + (2x + 1) + x + (2x + 1) = 6x + 2$ (b) $p = 44$ (c) $x = 30$
4. (a) $p = (x + 9) + (x + 12) + (x + 9) + (x + 12) = 4x + 42$
 (b) $p = 78$ (c) $x = 19$
5. (a) Area = $\frac{1}{2}\pi r^2$; perimeter = $\pi r + 2r$ (b) Area = 39.27 cm^2 ; perimeter = 25.71 cm
 (c) $r = \frac{40}{(\pi + 2)} = 7.78 \text{ cm}$ (d) $r = \sqrt{\frac{2 \times 18}{\pi}} = 3.39 \text{ cm}$
6. (a) $C = 50m + 180$ (b) £3.30 (c) 8.4 miles
7. (a) Amount made = $0.4x - 50$ (b) He makes a profit of £30.
 (c) He makes a loss of £10. (d) 375
8. (a) $M = W + 22$ (b) $W = M - 22$ (c) $M = 15$ (d) $W = -25$
9. (a) $p = 17$ (b) $C = 17x + 20$ (c) $4\frac{1}{2}$ hours
10. (a) Area of left hand shape = $(x + 1) \times (x + 10) + 1 \times (x + 4)$
 $= (x^2 + 11x + 10) + x + 4$
 $= x^2 + 12x + 14$
 Area of right hand shape = $(x + 7) \times (2x + 2)$
 $= 2x^2 + 16x + 14$
- (b) Alan is incorrect. The two shapes do not have the same area.
11. (a) $F = 60x + 40y = 60 \times 65 + 40 \times 80 = 3900 + 3200 = 7100$
 \therefore income = 7100 pence = £71.
- (b) $F = 60x + 40y \Rightarrow 4800 = 60 \times 50 + 40y$
 $\Rightarrow 4800 = 3000 + 40y \Rightarrow 1800 = 40y$
 $\Rightarrow y = 1800 \div 40 \Rightarrow y = 45$
 \therefore 45 tubs were sold.
- (c) 46%

11.4

Answers

- (d) (i) 15 000 {or 14 700 or 14 500}
(ii) 50 pence (iii) £7500 {or £7350 or £7250}
12. (a) $s = ut + \frac{1}{2}at^2 = (0.25 \times 3.5) + (0.5 \times (-0.05) \times 3.5^2)$
 $= 0.875 - 0.30625 = 0.56875$
 \therefore distance travelled = 0.56875 m forwards = 56.875 cm forwards
- (b) $v = u + at = 0.25 + ((-0.05) \times 3.5) = 0.25 - 0.175 = 0.075$
 \therefore final speed = 0.075 m/s forwards = 7.5 cm/s forwards
13. (a) If $n = 3$, $\frac{n(n^2 + 1)}{2} = \frac{3(3^2 + 1)}{2} = \frac{3 \times (9 + 1)}{2} = \frac{3 \times 10}{2} = \frac{30}{2} = 15$
 \therefore the formula works for Eleri's 3×3 magic square.
- (b)
- | | | | | | | | | | | |
|---------------------|---|---|----|----|----|-----|-----|-----|-----|-----|
| n | 1 | 2 | 3 | 4 | 5 | 6 | 7 | 8 | 9 | 10 |
| <i>magic number</i> | 1 | 5 | 15 | 34 | 65 | 111 | 175 | 260 | 369 | 505 |
-
- | | | | | | | | | | | |
|---------------------|-----|-----|------|------|------|------|------|------|------|------|
| n | 11 | 12 | 13 | 14 | 15 | 16 | 17 | 18 | 19 | 20 |
| <i>magic number</i> | 671 | 870 | 1105 | 1379 | 1695 | 2056 | 2465 | 2925 | 3439 | 4010 |
- Tony's magic square was 18×18 .
14. (a) If $x = 0$ and $y = 2$, then $y = 6 + c(10 - x)^2 \Rightarrow 2 = 6 + c(10 - 0)^2$
 $\Rightarrow 2 = 6 + 100c \Rightarrow -4 = 100c$
 $\Rightarrow c = -0.04$
- (b) When $x = 0$, $y = -0.1(x^2 - 6x - 16) = -0.1(0^2 - [6 \times 0] - 16)$
 $= (-0.1) \times (-16) = 1.6$
 \therefore the ball left Alan's hand at a height of 1.6 metres.

Practice Book *UNIT 12 Constructions and Loci*Answers

12.1 Recap: Angles and Scale Drawing

1. (a) $c = 180^\circ - 63^\circ$ (supplementary angles)

$$= 117^\circ$$

$$a = 63^\circ$$
 (opposite, then corresponding angles)

$$b = 180^\circ - a$$
 (supplementary angles)

$$= 180^\circ - 63^\circ$$

$$= 117^\circ$$

(b) $a = 48^\circ$ (opposite, then corresponding angles)

$$b = a$$
 (alternate angles)

$$= 48^\circ$$

$$c = 180^\circ - 48^\circ$$
 (angle corresponding to c is supplementary to 48°)

$$= 132^\circ$$

2. $a = 180^\circ - (65^\circ + 35^\circ)$

$$= 80^\circ$$

$$c = 65^\circ$$

$$b = 180^\circ - 65^\circ$$

$$= 115^\circ$$

$$d = 35^\circ$$

$$e = 180^\circ - 35^\circ$$

$$= 145^\circ$$

3. $x = 180^\circ - 112^\circ$ (supplementary angles)

$$= 68^\circ$$

$$p = x = 68^\circ$$
 (corresponding)

$$r = 180^\circ - p$$
 (supplementary) $= 180^\circ - 68^\circ = 112^\circ$

$$q = 180^\circ - (46^\circ + 68^\circ)$$
 (angles of triangle)

$$= 66^\circ$$

$$s = 180^\circ - q$$
 (supplementary)

$$= 180^\circ - 66^\circ = 114^\circ$$

$$y = q$$
 (corresponding) $= 66^\circ$

$$z = 180^\circ - y$$
 (supplementary) $= 180^\circ - 66^\circ = 114^\circ$

12.1

Answers

4. Scale drawing
5. (a) 90° (b) 6 (c) 30° (d) 150° (e) 1 hour
6. (a) A and C (b) Drawing of obtuse angle (c) South (d) South
7. (a) $k = 180^\circ - 70^\circ = 110^\circ$
 (b) $3m + 3 \times 70^\circ = 360^\circ$
 $\Rightarrow m = 50^\circ$
8. (a) $a = 100^\circ$, $b = 140^\circ$, $c = 120^\circ$ (b) $d = 50^\circ$, $e = 130^\circ$ (c) 60
9. Drawing
10. $\angle ABC = 3x^\circ$ ($AB = AC$)
 $\Rightarrow \angle DBC = 2x^\circ$
 $\Rightarrow \angle BDC = \angle BCD = 3x^\circ$ ($BD = BC$)
 $2x + 3x + 3x = 180^\circ$ (angles of a triangle)
 $\Rightarrow x = 22\frac{1}{2}^\circ$

12.2 Constructions

1. Drawing
2. Drawing
3. Drawing
4. (a) Drawing (b) The three perpendicular bisectors meet at a point. (d) Yes
5. (a), (b), (c) Drawing
6. Drawings
7. (a) Drawing (b) $BC = 5.6$ cm (c) Area = 16.1 cm²
8. (a) No (both incorrect) (b)

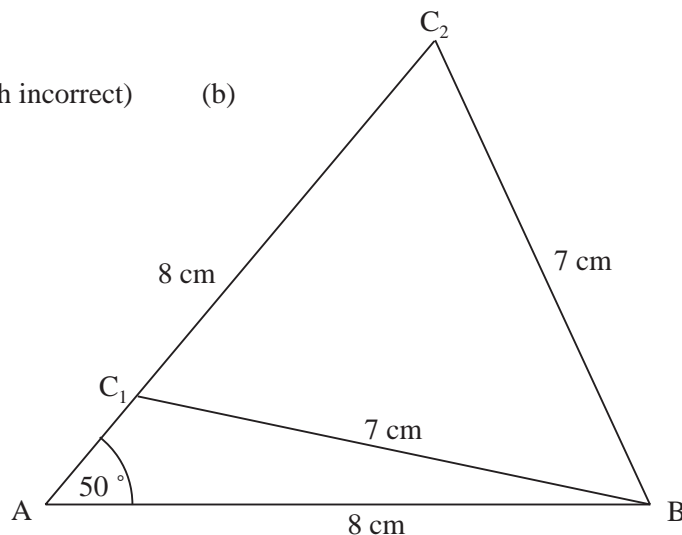

12.2

Answers

9. Drawings
10. The perpendicular bisectors pass through the centre of the circle.
Yes
11. Drawing
12. Drawing
13. (a) C (b) Drawing

12.3 Loci

1.

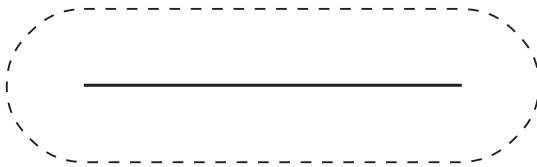

2.

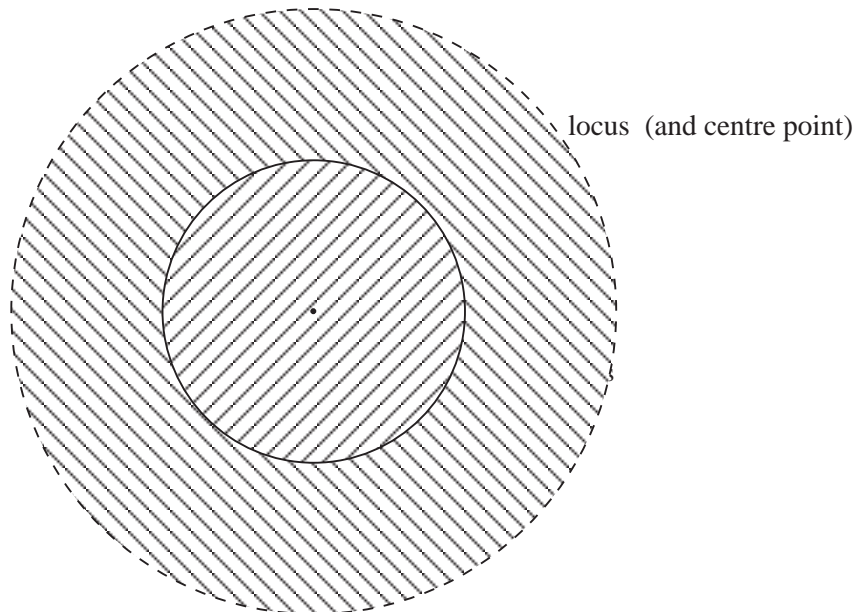

3. (a) (b)

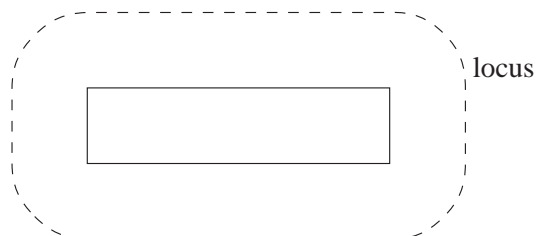

- (c) Drawing as above, but with rectangle 6 cm by 5 cm, and loci of the points 1 cm from the rectangle, both inside and outside.

12.3

Answers

4.

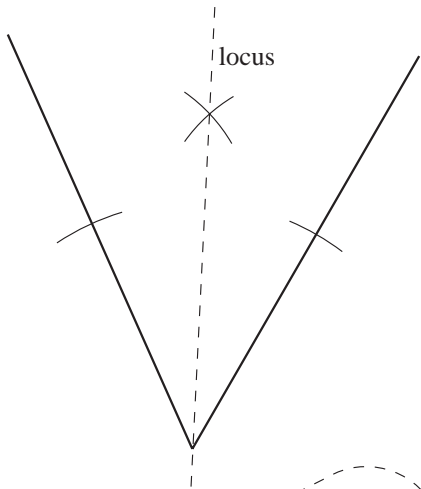

5.

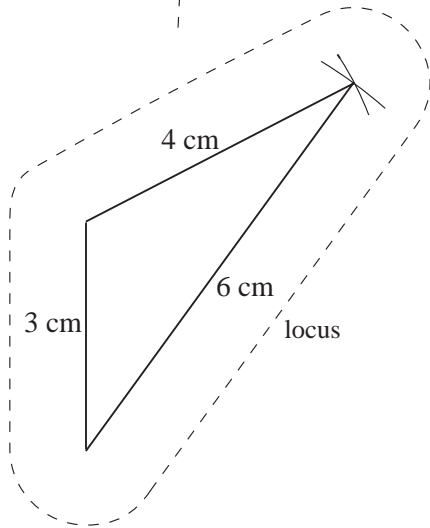

6.

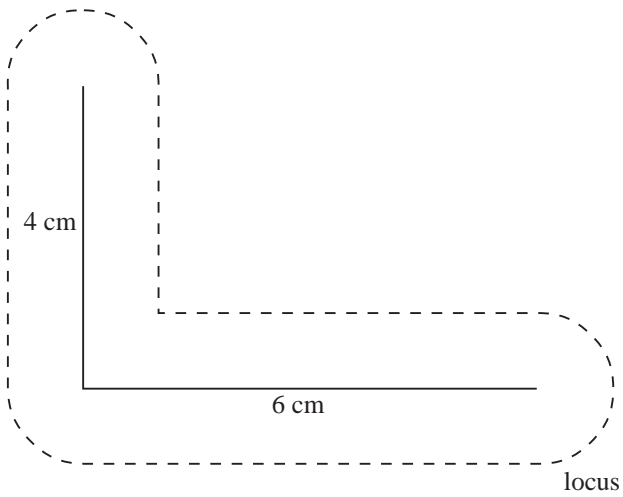

12.3

Answers

7.

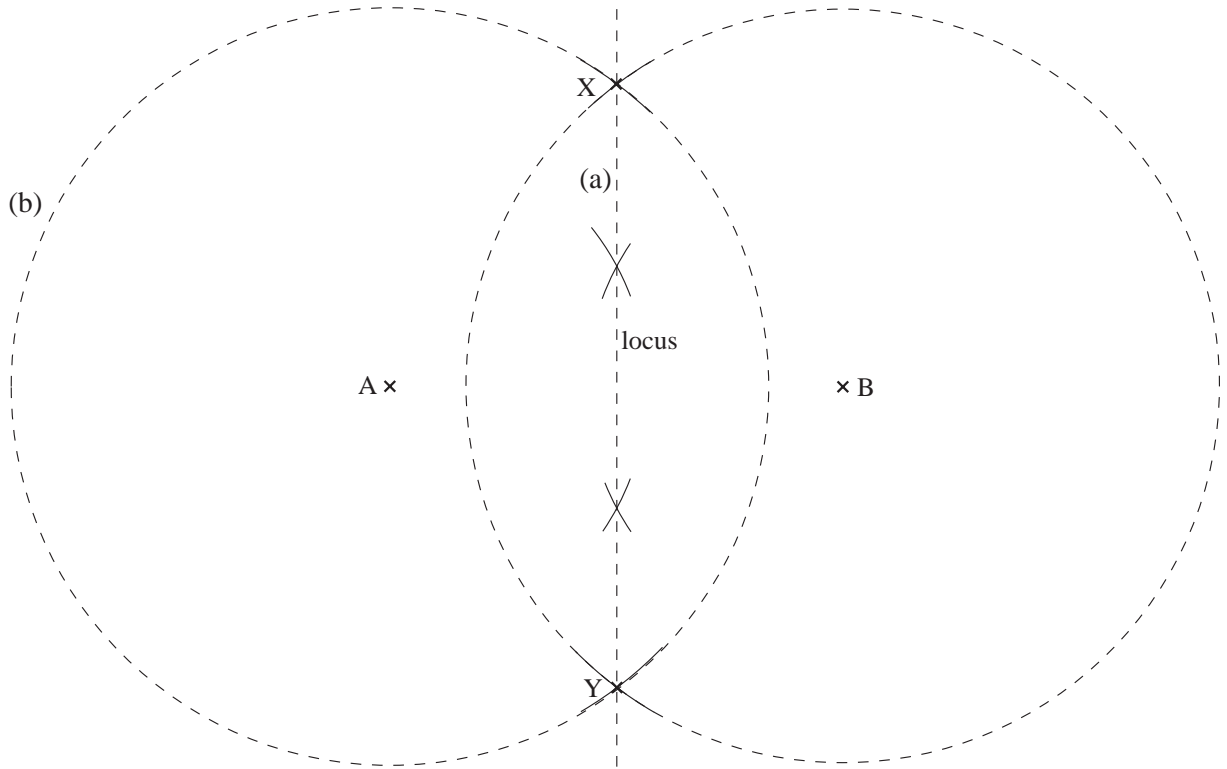

(c) Points X and Y are 5 cm from A and B.

8. Locus is a circle, diameter XY, where

$$AX = 6 \text{ cm} \quad BX = 3 \text{ cm}$$

$$AY = 18 \text{ cm} \quad BY = 9 \text{ cm}$$

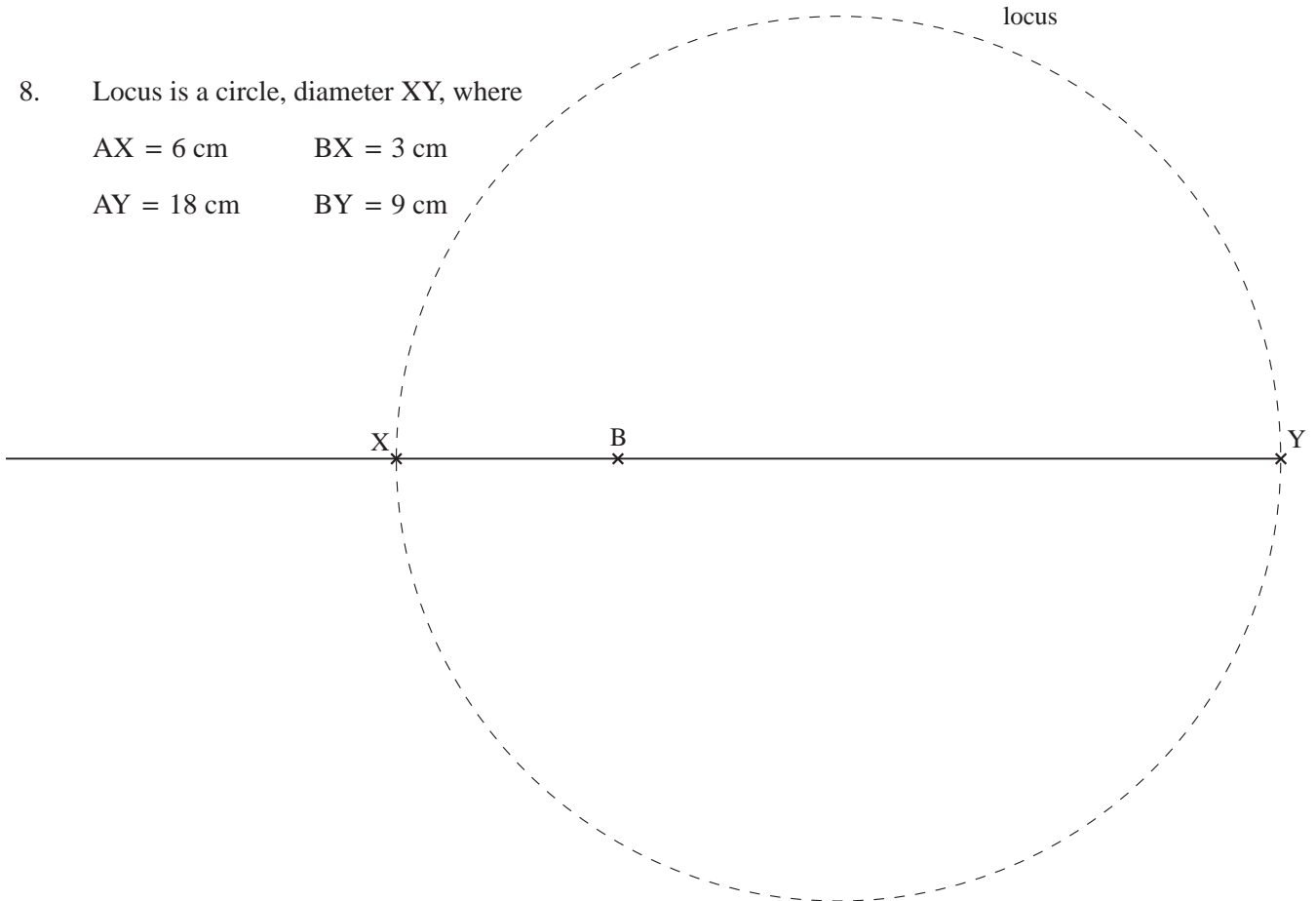

12.3

Answers

9.

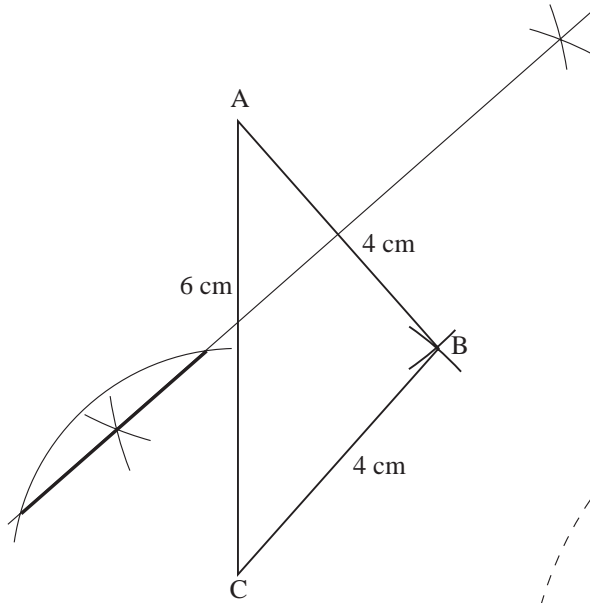

SCALE 1 cm to 2 m
 Regions in which tree can be planted

10.

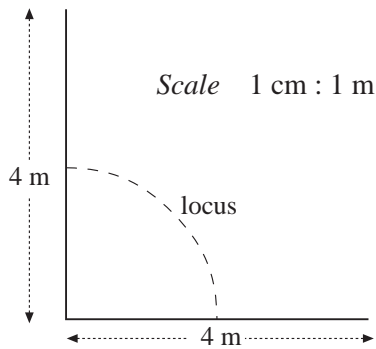

11. (a) Drawing opposite

(b) $\text{Area} = \pi \times 3^2 - \pi \times 2^2$
 $\approx 15.7 \text{ m}^2$

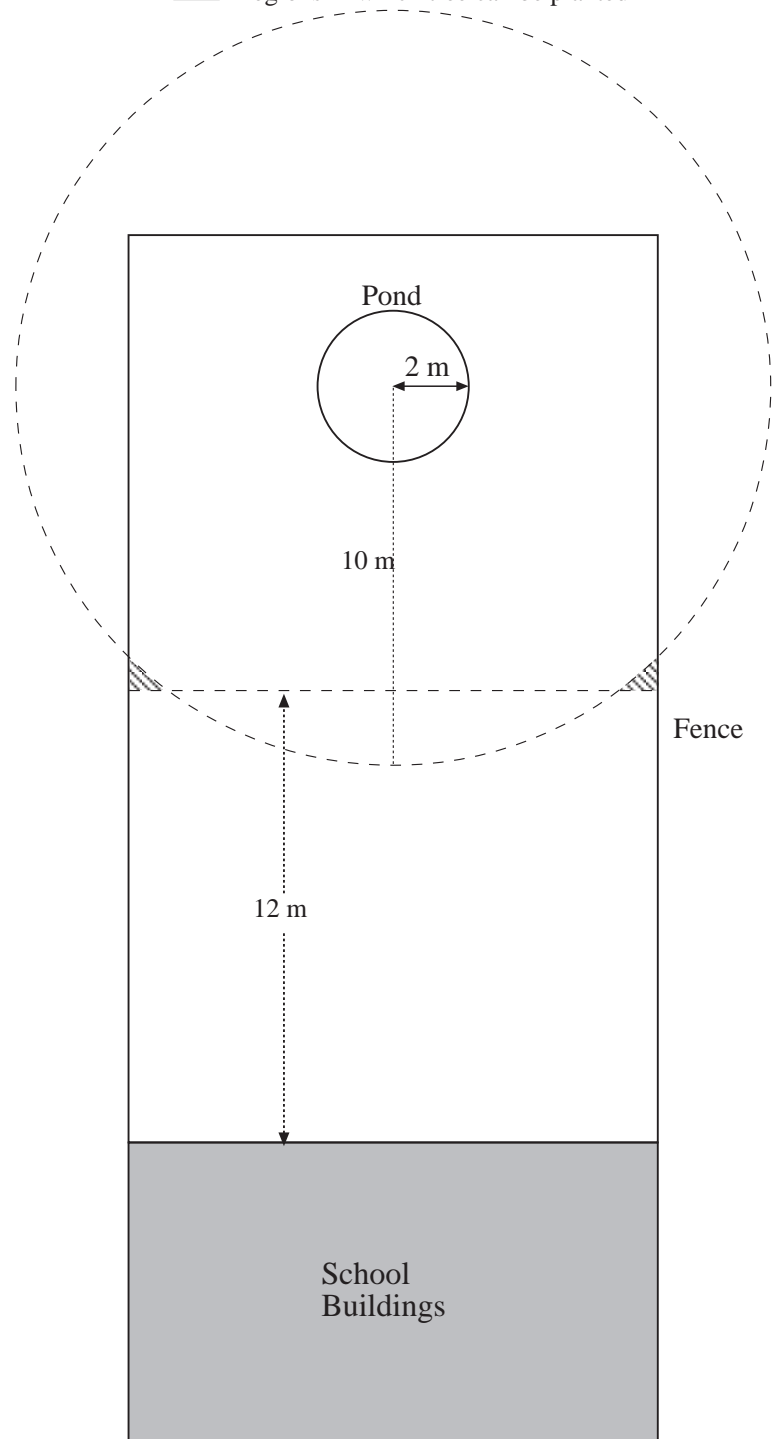

Practice Book *UNIT 13 Graphs, Equations and Inequalities*

Answers

13.1 Linear Inequalities

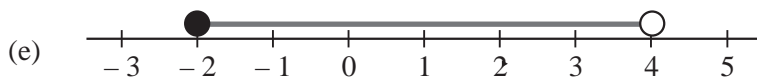
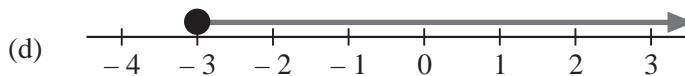
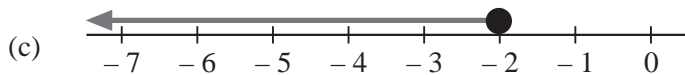
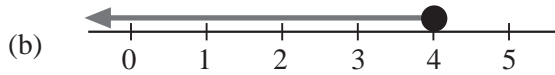
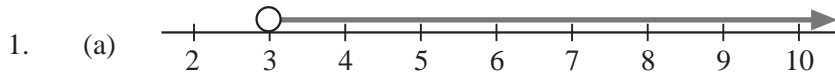

2. (a) $x \geq -2$ (b) $x < 2$ (c) $-2 < x < 3$
 (d) $-3 \leq x < -1$ (e) $-4 < x \leq 2$

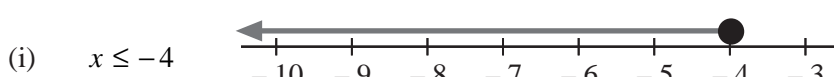
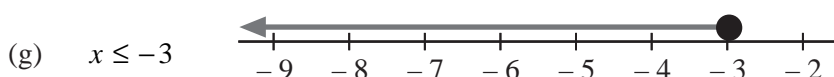
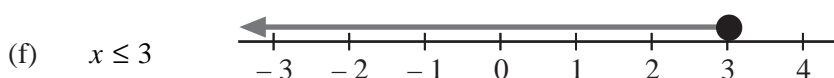
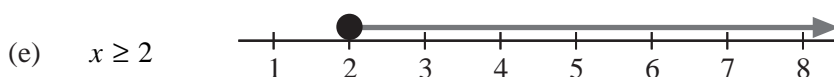
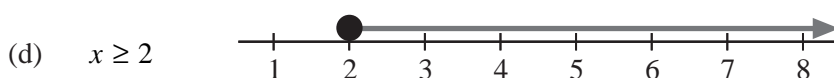
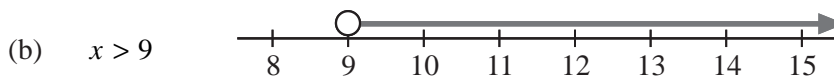
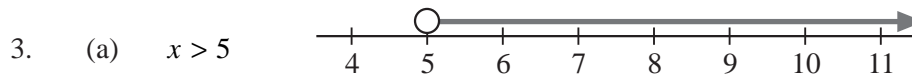

13.1

Answers

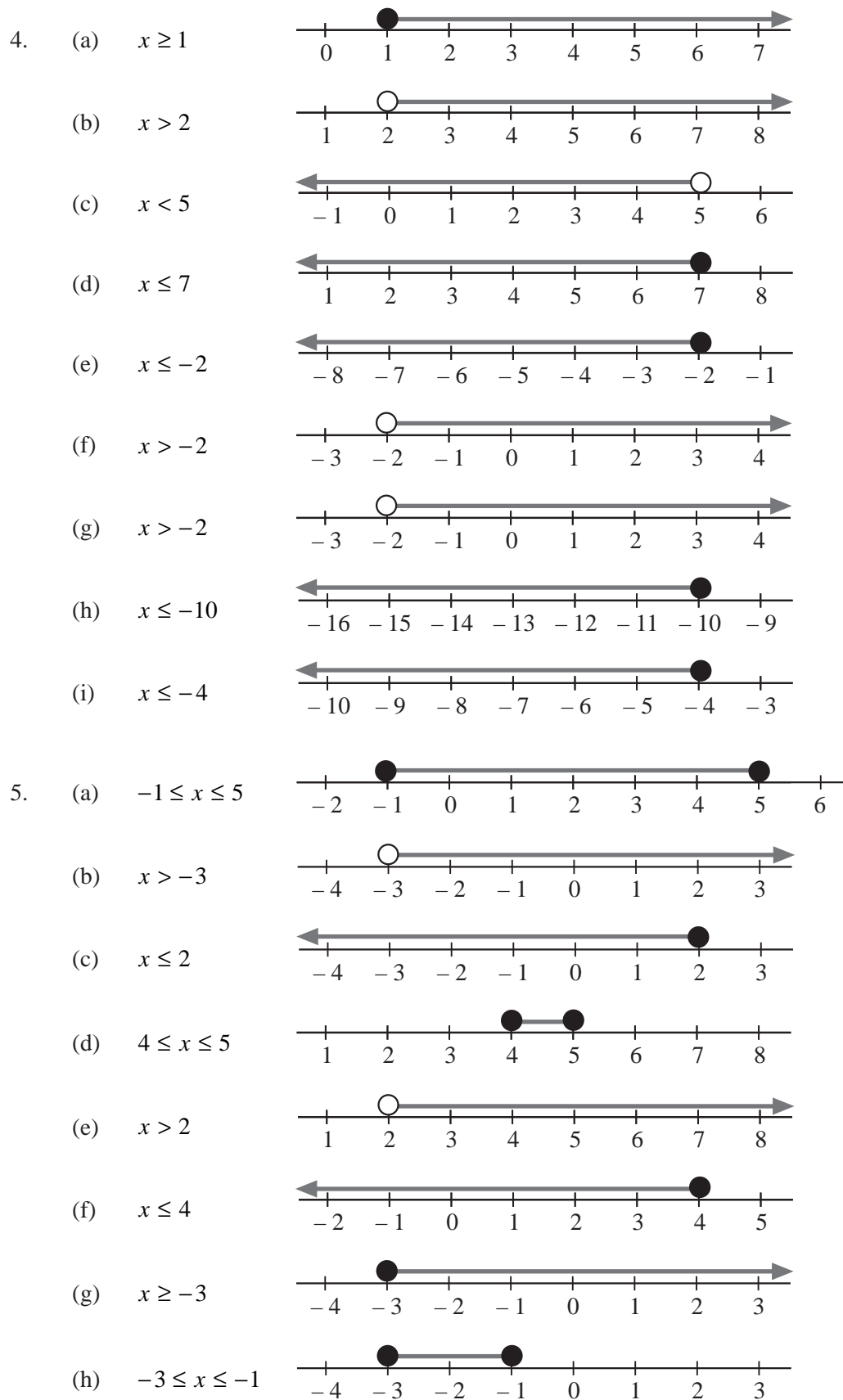

13.1

Answers

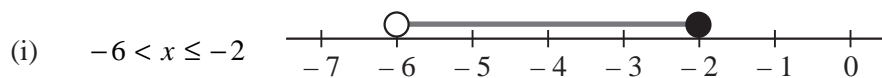

$$\begin{aligned}
 6. \quad (x + 8) + x + (x + 8) + x < 44 &\Rightarrow 4x + 16 < 44 \\
 &\Rightarrow 4x < 28 \\
 &\Rightarrow x < 7
 \end{aligned}$$

$$\begin{aligned}
 7. \quad 21 < (x + 1) + (x + 2) + (x + 3) \leq 30 &\Rightarrow 21 < 3x + 6 \leq 30 \\
 &\Rightarrow 15 < 3x \leq 24 \\
 &\Rightarrow 5 < x \leq 8
 \end{aligned}$$

$$\begin{aligned}
 8. \quad 10 \leq 5(x + 4) < 50 &\Rightarrow 10 \leq 5x + 20 < 50 \\
 &\Rightarrow -10 \leq 5x < 30 \\
 &\Rightarrow -2 \leq x < 6
 \end{aligned}$$

$$9. \quad 3 < \frac{30}{v} < 5 \Rightarrow 6 < v < 10$$

$$\begin{aligned}
 10. \quad 10 \leq \pi r^2 < 20 &\Rightarrow \sqrt{\frac{10}{\pi}} \leq r < \sqrt{\frac{20}{\pi}} \\
 &\Rightarrow 1.784124116 \text{ m} \leq r < 2.523132522 \text{ m} \\
 &\Rightarrow 1.78 \text{ m} < r < 2.52 \text{ m (to the nearest cm)}
 \end{aligned}$$

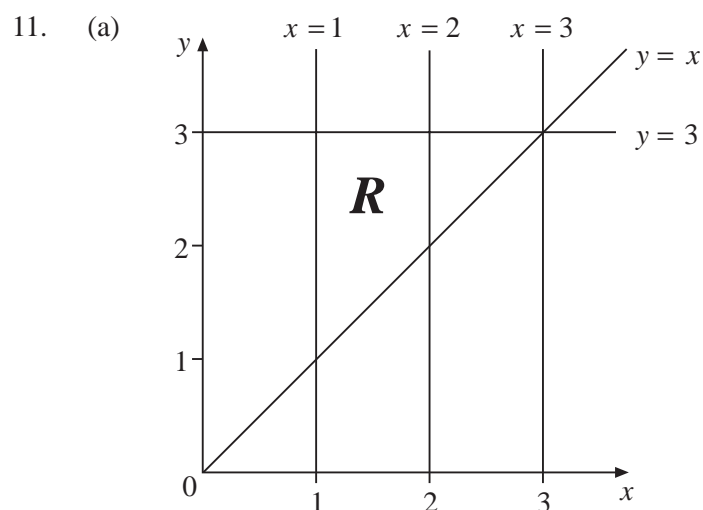

(b) $y < x$, $y > 2$ and $x < 4$

13.2

Answers

13.2 Graphs of Quadratic Functions

1. (a)

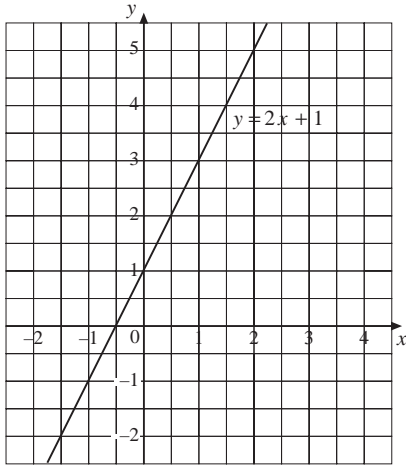

(b) Gradient = 2

2.

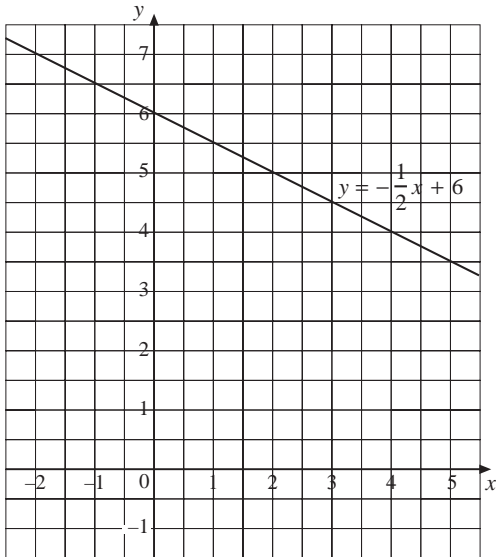

3. (a)

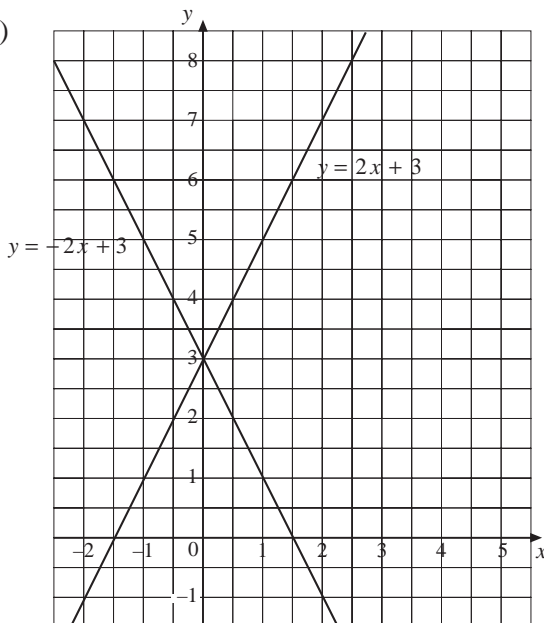

(b) The transformation is a reflection in the y-axis.

13.2

Answers

4. (a)

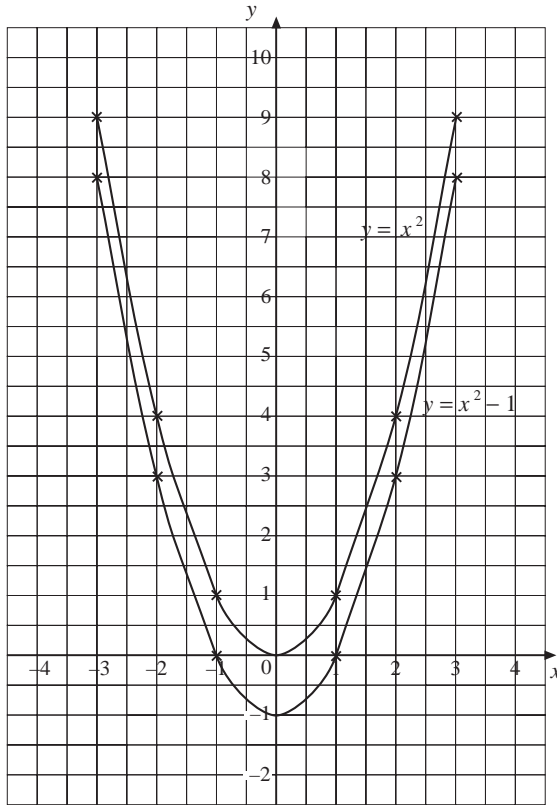

(b) The graph $y = x^2 - 1$ is a translation of the graph $y = x^2$ along the vector $\begin{pmatrix} 0 \\ -1 \end{pmatrix}$.

5. (a)

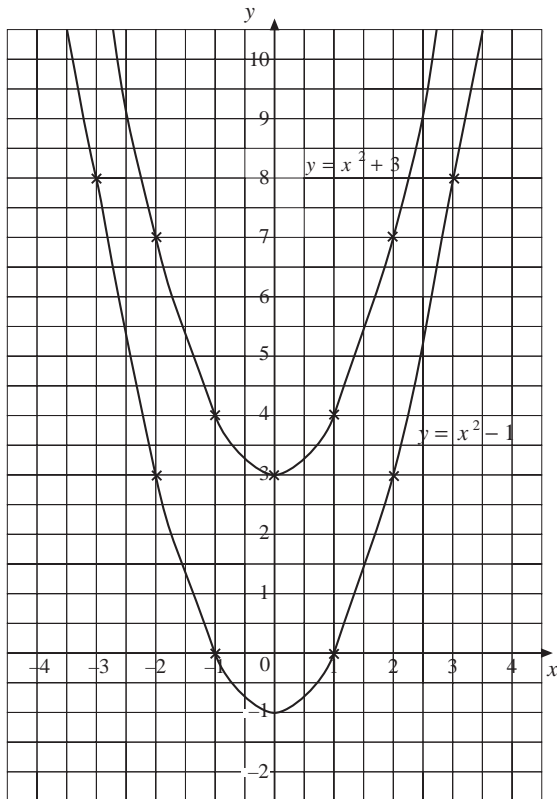

(b) The graph $y = x^2 - 1$ is a translation of the graph $y = x^2 + 3$ along the vector $\begin{pmatrix} 0 \\ -4 \end{pmatrix}$.

13.2

Answers

6. $y = x^2 + 1$ is a translation of the graph $y = x^2 - 5$ along the vector $\begin{pmatrix} 0 \\ 6 \end{pmatrix}$.

$y = x^2 + 1$ is a translation of the graph $y = x^2 + 6$ along the vector $\begin{pmatrix} 0 \\ -5 \end{pmatrix}$.

$y = x^2 - 5$ is a translation of the graph $y = x^2 + 6$ along the vector $\begin{pmatrix} 0 \\ -11 \end{pmatrix}$.

7. (a)

| | | | | | | | | | |
|------------|----|----|----|----|---|---|---|----|----|
| x | -4 | -3 | -2 | -1 | 0 | 1 | 2 | 3 | 4 |
| $x^2 + 2x$ | 8 | 3 | 0 | -1 | 0 | 3 | 8 | 15 | 24 |

(b)

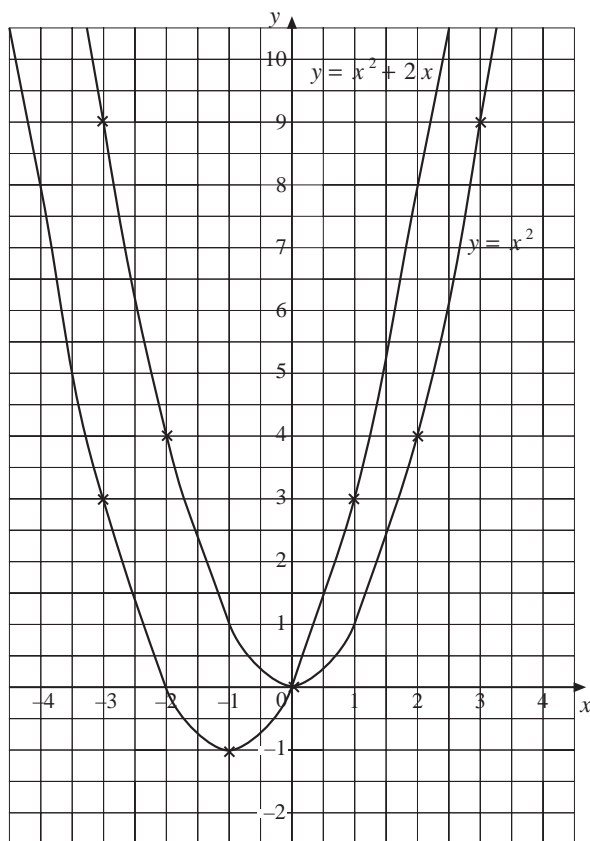

(c) Graph $y = x^2 + 2x$ is a translation of the graph $y = x^2$ along the vector $\begin{pmatrix} -1 \\ -1 \end{pmatrix}$.

13.2

Answers

8. (a) and (b)

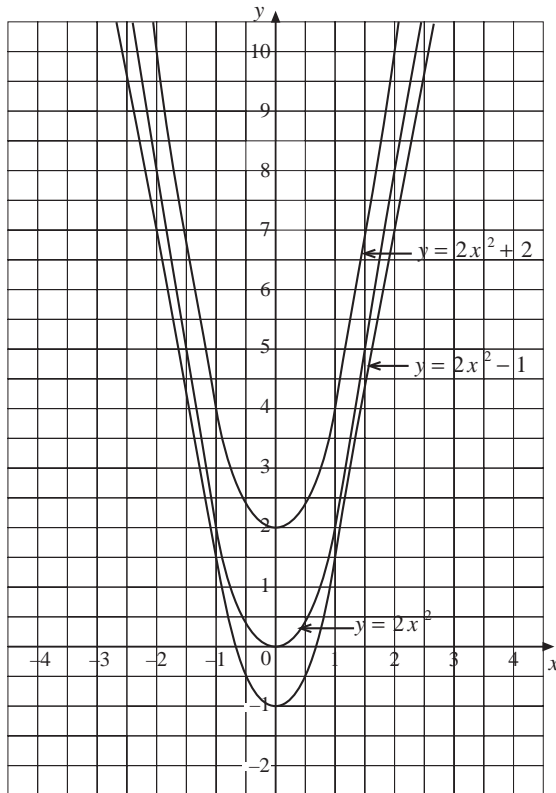

(c) $y = 2x^2 - 1$ is a translation of the graph $y = 2x^2$ along the vector $\begin{pmatrix} 0 \\ -1 \end{pmatrix}$.

$y = 2x^2 + 2$ is a translation of the graph $y = 2x^2$ along the vector $\begin{pmatrix} 0 \\ 2 \end{pmatrix}$.

$y = 2x^2 - 1$ is a translation of the graph $y = 2x^2 + 2$ along the vector $\begin{pmatrix} 0 \\ -3 \end{pmatrix}$.

9. (a)

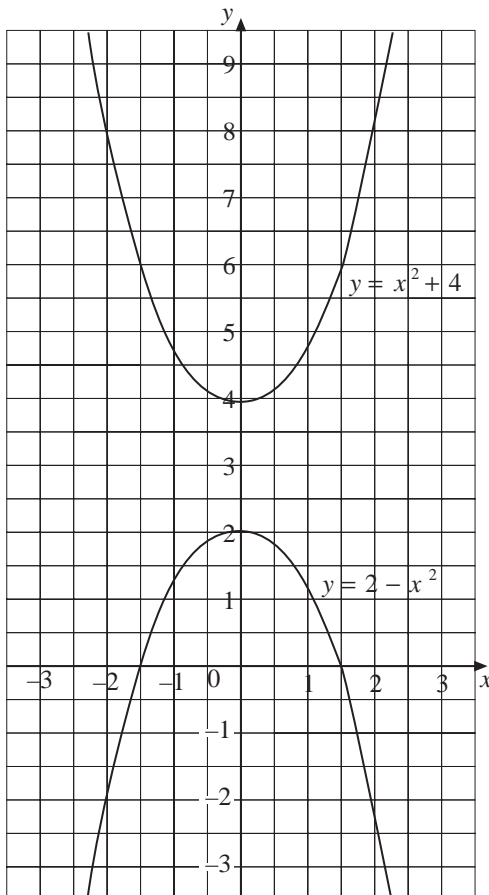

(b) The graph $y = 2 - x^2$ is a reflection of the curve of $y = x^2 + 4$ in the line $y = 3$.

13.2

Answers

10. (a)

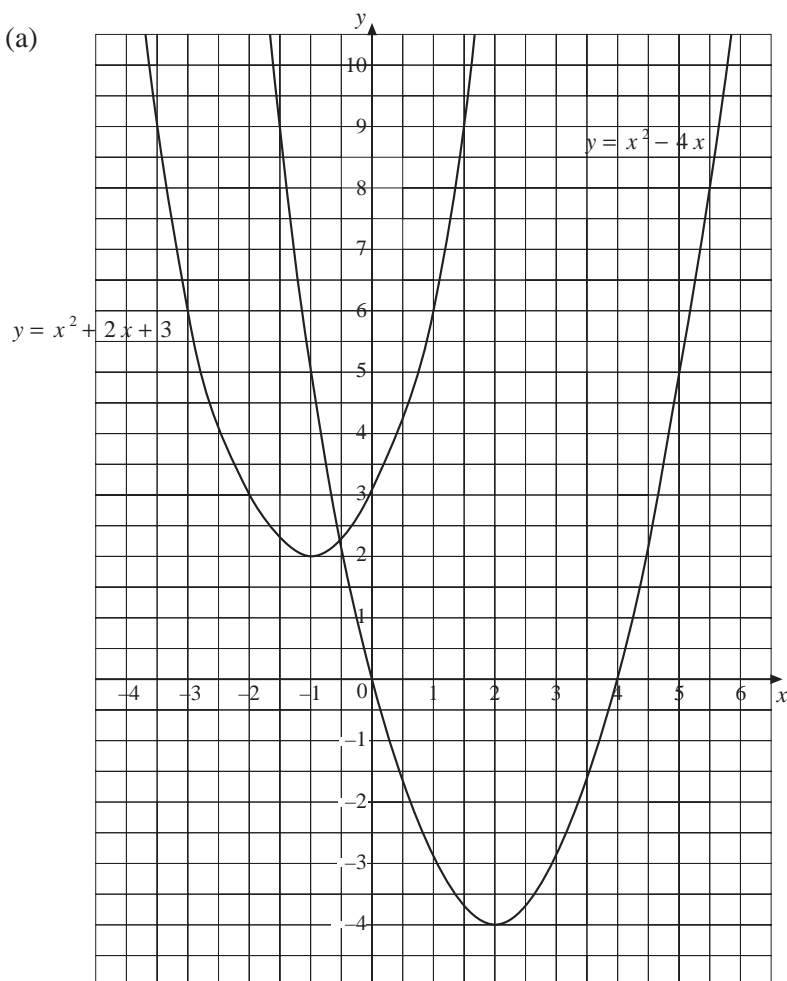

(b)

The graph

$y = x^2 + 2x + 3$ is a translation of the graph $y = x^2 - 4x$ along the

vector $\begin{pmatrix} -3 \\ 6 \end{pmatrix}$.

11. (a)

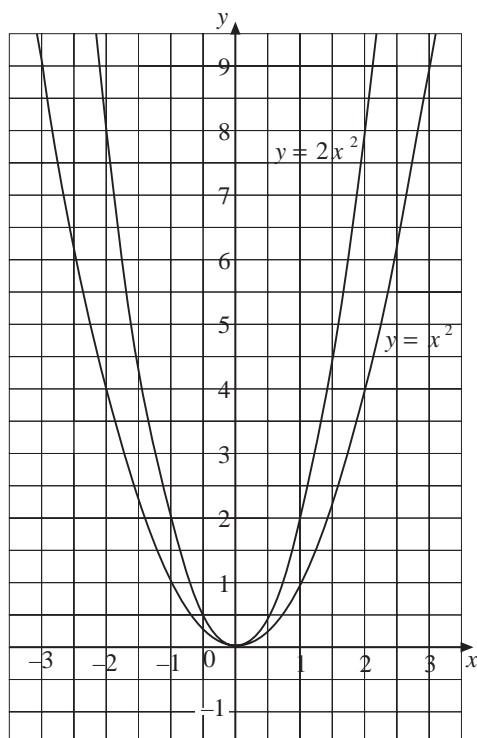

(b) $y = -x^2$

(c) $y = x^2 + 1$

(d) $y > x^2$ and $y < 2$

13.3

Answers

13.3 Graphs of Cubic and Reciprocal Functions

1. (a)

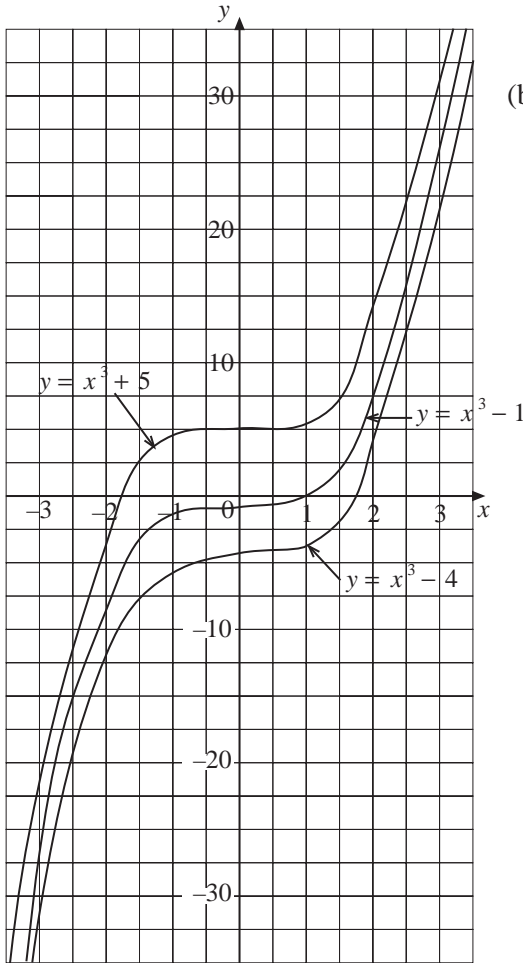

(b) $y = x^3 - 1$ is a translation of the graph

$y = x^3 + 5$ along the vector $\begin{pmatrix} 0 \\ -6 \end{pmatrix}$.

$y = x^3 - 4$ is a translation of the graph

$y = x^3 + 5$ along the vector $\begin{pmatrix} 0 \\ -9 \end{pmatrix}$.

$y = x^3 - 1$ is a translation of the graph

$y = x^3 - 4$ along the vector $\begin{pmatrix} 0 \\ 3 \end{pmatrix}$.

2. (a)

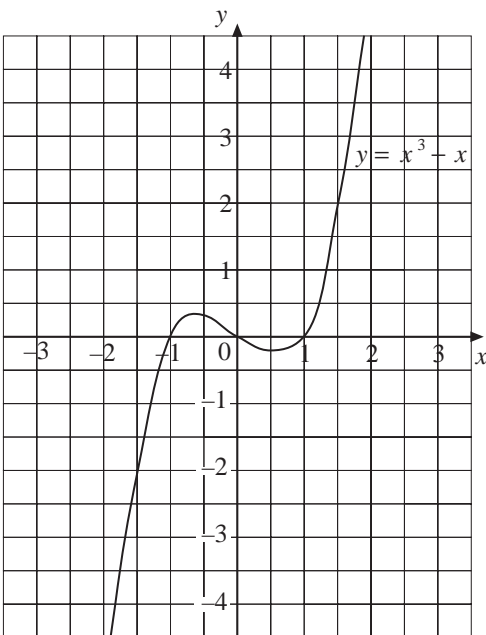

(b) The curve has rotational symmetry of order 2 about the origin.

13.3

Answers

3. (a)

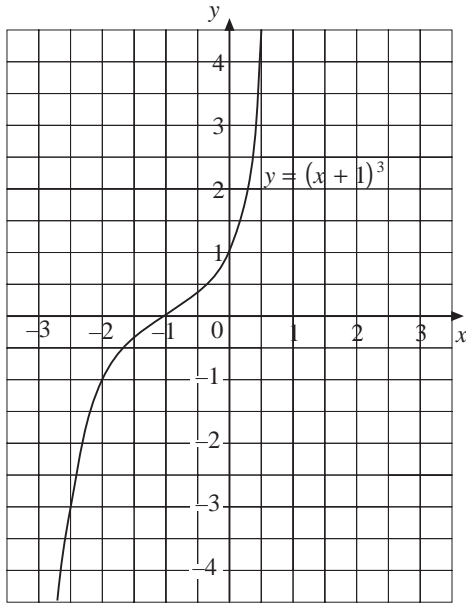

(b) $y = (x + 1)^3$ is a translation of the graph

$y = x^3$ along the vector $\begin{pmatrix} -1 \\ 0 \end{pmatrix}$

(c) The curve has rotational symmetry of order 2 about $(-1, 0)$.

4. (a)

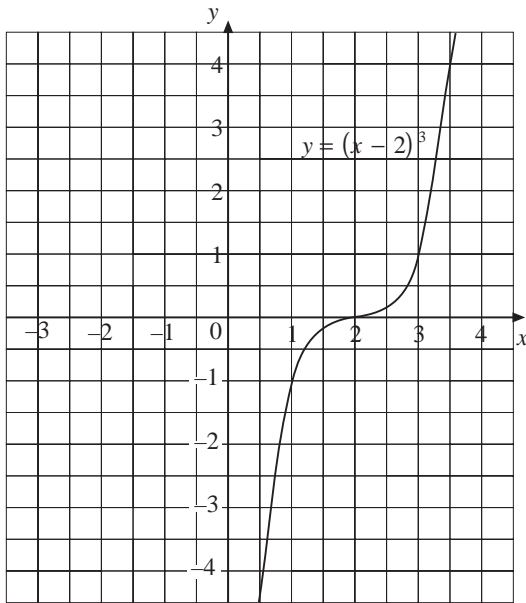

(b) The curve has rotational symmetry of order 2 about $(2, 0)$.

5.

(b) $y = 2 - x^3$ is a reflection of the graph $y = x^3$ in the line $y = 1$, and vice versa.

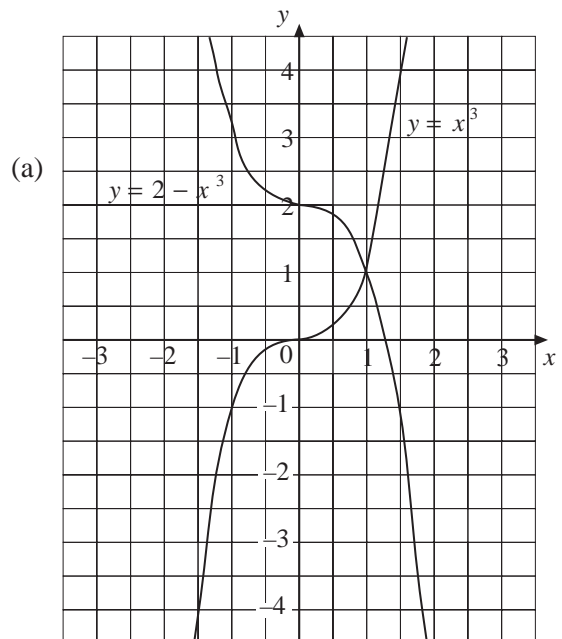

13.3

Answers

6. (a)

| | | | | | | | | |
|---------------|----------------|----------------|----|----------------|---------------|---|---------------|---------------|
| x | -4 | -2 | -1 | $-\frac{1}{2}$ | $\frac{1}{2}$ | 1 | 2 | 4 |
| $\frac{1}{x}$ | $-\frac{1}{4}$ | $-\frac{1}{2}$ | -1 | -2 | 2 | 1 | $\frac{1}{2}$ | $\frac{1}{4}$ |

(c) The curve is symmetrical about the lines $y = x$ and $y = -x$.
The curve has rotational symmetry of order 2 about the origin.

(b)

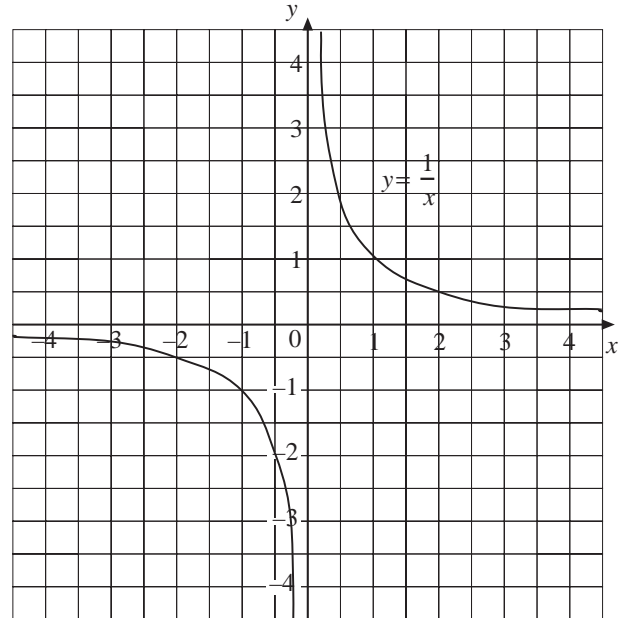

7.

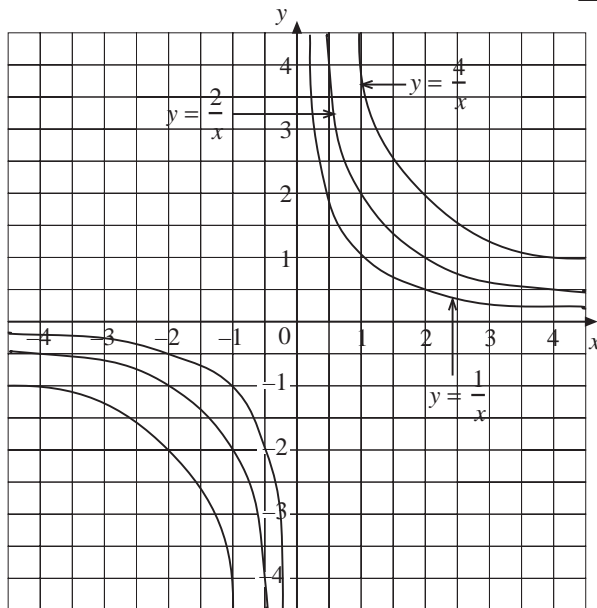

8.

(b) The line $y = 7 - x$ and the curve $y = \frac{6}{x}$ meet at (6, 1) and (1, 6).

(a)

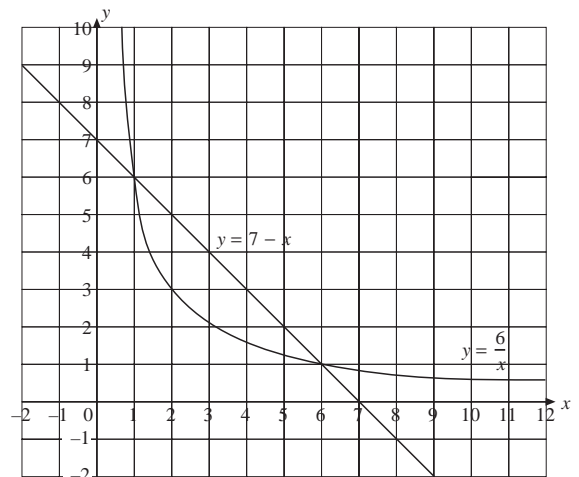

13.3

Answers

9. (a)

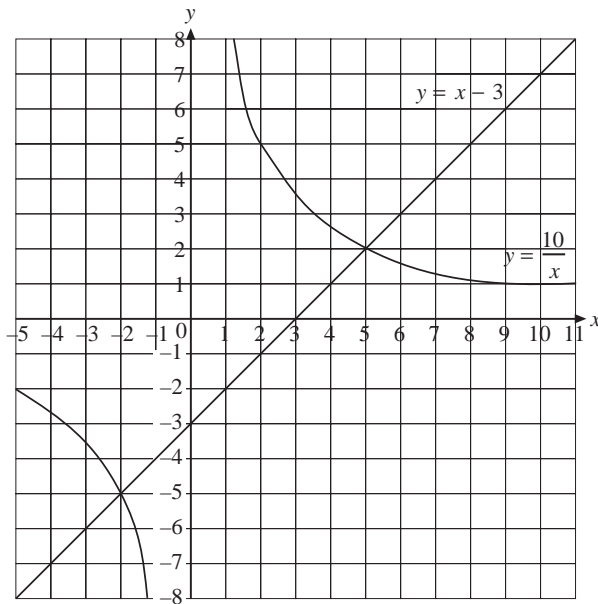

(b) The line $y = x - 3$ meets the curve $y = \frac{10}{x}$ at the points $(5, 2)$ and $(-2, -5)$.

10. (a) The curve $y = x^2$ meets the curve $y = \frac{1}{x}$ at the point $(1, 1)$.

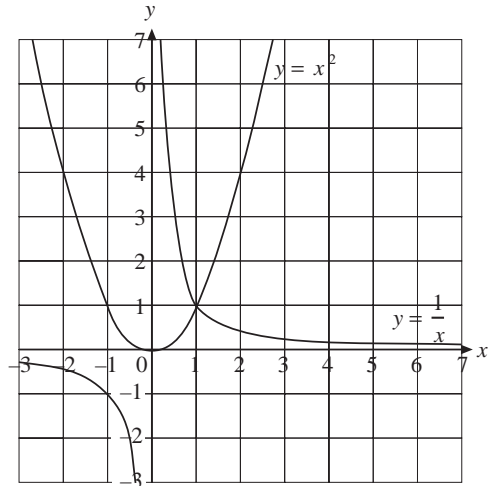

(b) The curve $y = x^3$ meets the curve $y = \frac{1}{x}$ at the points $(1, 1)$ and $(-1, -1)$.

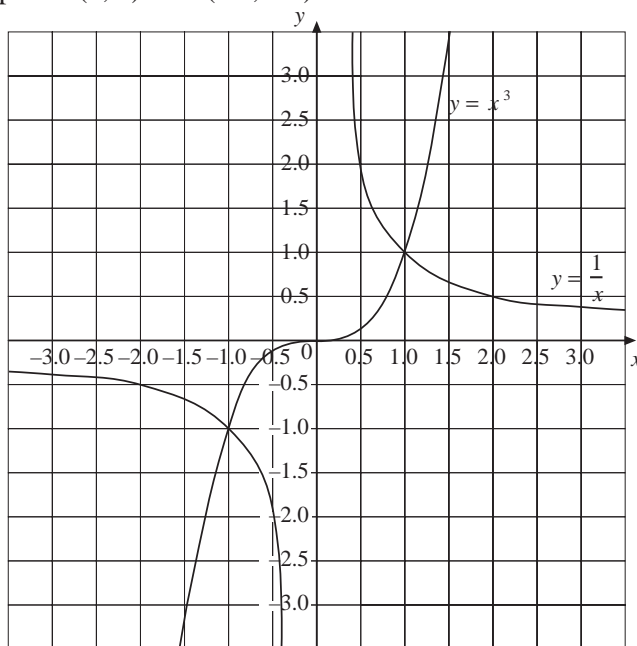

13.4

Answers

13.4 Solving Non-Linear Equations

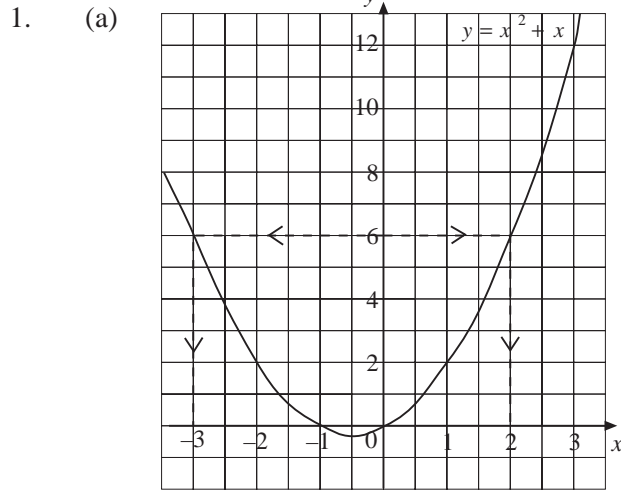

(b) The solutions are $x = -3$ and $x = 2$.

2.

(b) (i) $x = 2.25$ or -1.75

(ii) $x = 1.85$ or -1.35

3. The following are the correct answers to the given equations to 2 decimal places; the answers obtained visually from the graph are in brackets.

(a) $x = 3.43$ (3.6)

(b) $x = -2.66$ (-2.7)

(c) $x = -1.76, -0.36$ or 3.12 (-1.75, -0.35 or 3.2)

(d) $x = -2.32, 0.64$ or 2.68 (-2.3, 0.65 or 2.7)

(a)

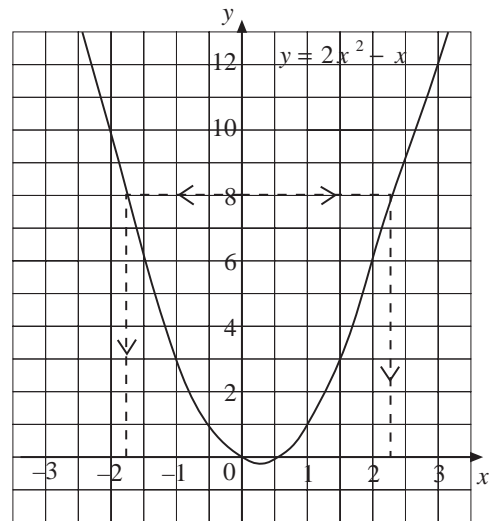

4.

| <i>Trial x</i> | $x^3 + x$ | <i>Comment</i> |
|----------------|--------------|--------------------|
| 9 | 738 | $9 < x$ |
| 10 | 1010 | $9 < x < 10$ |
| 9.8 | 950.992 | $9.8 < x < 10$ |
| 9.9 | 980.199 | $9.9 < x < 10$ |
| 9.94 | 992.047784 | $9.94 < x < 10$ |
| 9.95 | 995.024875 | $9.95 < x < 10$ |
| 9.96 | 998.007936 | $9.96 < x < 10$ |
| 9.97 | 1000.99697 | $9.96 < x < 9.97$ |
| 9.965 | 999.50170713 | $9.965 < x < 9.97$ |

So the solution is $x = 9.97$ (to 2 decimal places)

13.4

Answers

5.

| <i>Trial x</i> | $x + \sqrt{x}$ | <i>Comment</i> |
|----------------|----------------|------------------|
| 3.1 | 4.86068169 | 3.1 < x |
| 3.2 | 4.98885438 | 3.2 < x |
| 3.3 | 5.11659021 | 3.2 < x < 3.3 |
| 3.21 | 5.00164729 | 3.20 < x < 3.21 |
| 3.205 | 4.99525138 | 3.205 < x < 3.21 |

So the solution is $x = 3.21$ (to 2 d.p.).

6. From the graph,
 $x = 1.1$ or -7.1

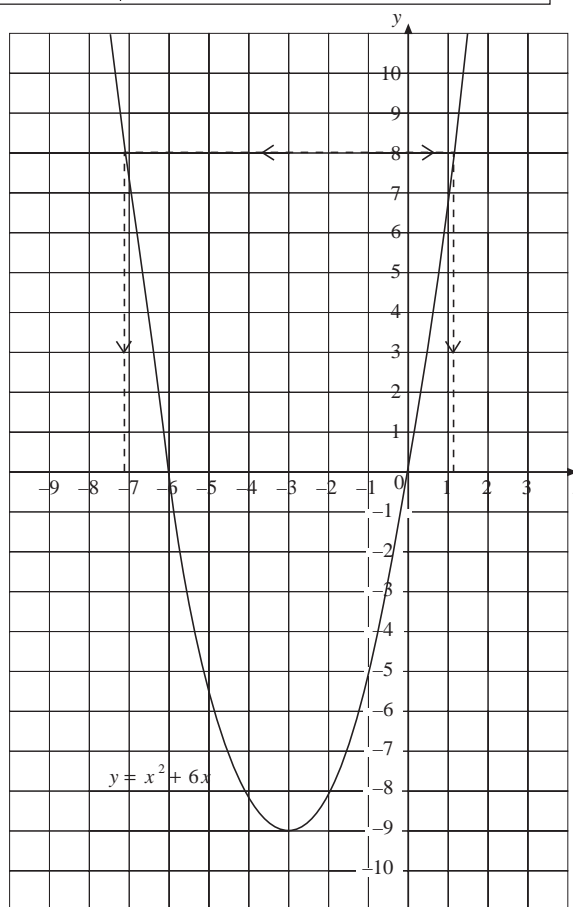

| <i>Trial x</i> | $x^2 + 6x$ | <i>Comment</i> |
|----------------|------------|------------------|
| 1 | 7 | 1 < x |
| 2 | 16 | 1 < x < 2 |
| 1.1 | 7.81 | 1.1 < x < 2 |
| 1.2 | 8.64 | 1.1 < x < 1.2 |
| 1.11 | 7.8921 | 1.11 < x < 1.2 |
| 1.12 | 7.9744 | 1.12 < x < 1.2 |
| 1.13 | 8.0569 | 1.12 < x < 1.13 |
| 1.125 | 8.015625 | 1.12 < x < 1.125 |

13.4

Answers

| <i>Trial x</i> | $x^2 + 6x$ | <i>Comment</i> |
|----------------|-------------|----------------------|
| -7 | 7.00000000 | $x < -7$ |
| -8 | 16.00000000 | $-8 < x < -7$ |
| -7.1 | 7.81000000 | $-8 < x < -7.1$ |
| -7.2 | 8.64000000 | $-7.2 < x < -7.1$ |
| -7.11 | 7.89210000 | $-7.2 < x < -7.11$ |
| -7.12 | 7.97440000 | $-7.2 < x < -7.12$ |
| -7.13 | 8.05690000 | $-7.13 < x < -7.12$ |
| -7.125 | 8.01562500 | $-7.125 < x < -7.12$ |

So the solution is $x = 1.12$ or -7.12 (to 2 decimal places).

7. (a) From the graph the solutions are $x = 0.2$ and 7.8

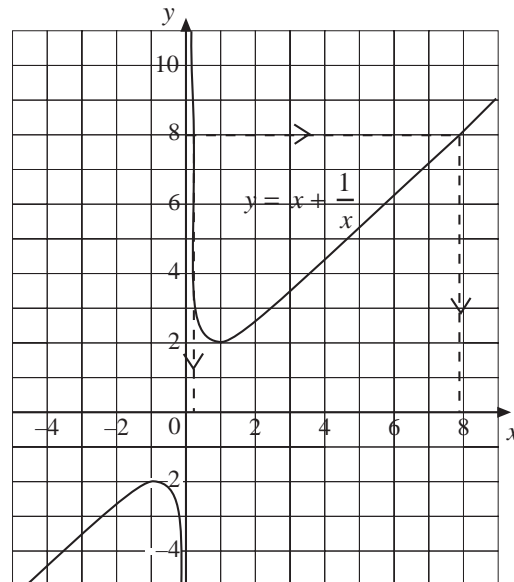

(b)

| <i>Trial x</i> | $x + \frac{1}{x}$ | <i>Comment</i> |
|----------------|-------------------|--------------------|
| 0.1 | 10.1 | $0.1 < x$ |
| 0.2 | 5.2 | $0.1 < x < 0.2$ |
| 0.15 | 6.81666667 | $0.1 < x < 0.15$ |
| 0.14 | 7.28285714 | $0.1 < x < 0.14$ |
| 0.13 | 7.82230769 | $0.1 < x < 0.13$ |
| 0.12 | 8.45333333 | $0.12 < x < 0.13$ |
| 0.125 | 8.125 | $0.125 < x < 0.13$ |

13.4

Answers

| <i>Trial x</i> | $x + \frac{1}{x}$ | <i>Comment</i> |
|----------------|-------------------|--------------------|
| 7.8 | 7.92820513 | $7.8 < x$ |
| 7.9 | 8.02658228 | $7.8 < x < 7.9$ |
| 7.85 | 7.97738854 | $7.85 < x < 7.9$ |
| 7.86 | 7.98722646 | $7.86 < x < 7.9$ |
| 7.87 | 7.99706480 | $7.87 < x < 7.9$ |
| 7.88 | 8.00690355 | $7.87 < x < 7.88$ |
| 7.875 | 8.00198413 | $7.87 < x < 7.875$ |

So the solution to $x + \frac{1}{x}$ is $x = 0.13$ or 7.87 (to 2 decimal places).

8.

| <i>Trial x</i> | $8x^2 - x^3$ | <i>Comment</i> |
|----------------|--------------|------------------|
| 0 | 0 | $0 < x$ |
| 1 | 7 | $0 < x < 1$ |
| 0.7 | 3.577 | $0.7 < x < 1$ |
| 0.8 | 4.608 | $0.8 < x < 1$ |
| 0.9 | 5.751 | $0.8 < x < 0.9$ |
| 0.85 | 5.165875 | $0.8 < x < 0.85$ |

| <i>Trial x</i> | $8x^2 - x^3$ | <i>Comment</i> |
|----------------|--------------|--------------------|
| 0 | 0 | $x < 0$ |
| -1 | 9 | $-1 < x < 0$ |
| -0.6 | 3.096 | $-0.6 < x < 0$ |
| -0.7 | 4.263 | $-0.7 < x < 0$ |
| -0.8 | 5.632 | $-0.8 < x < -0.7$ |
| -0.75 | 4.921875 | $-0.8 < x < -0.75$ |

| <i>Trial x</i> | $8x^2 - x^3$ | <i>Comment</i> |
|----------------|--------------|------------------|
| 7.7 | 17.787 | $7.7 < x$ |
| 7.8 | 12.168 | $7.8 < x$ |
| 7.9 | 6.241 | $7.9 < x$ |
| 8 | 0 | $7.9 < x < 8$ |
| 7.95 | 3.160125 | $7.9 < x < 7.95$ |

Graph on next page.

So the complete solution to $8x^2 - x^3 = 5$ is $x = -0.8, 0.8$ or 7.9 (to 1 decimal place).

13.4

Answers

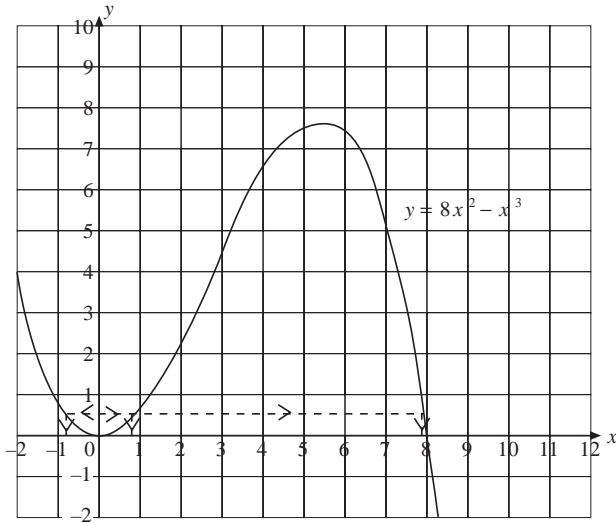

9. The graph shows that the solution is between $x = -1$ and -2 , and is approximately -1.3 .

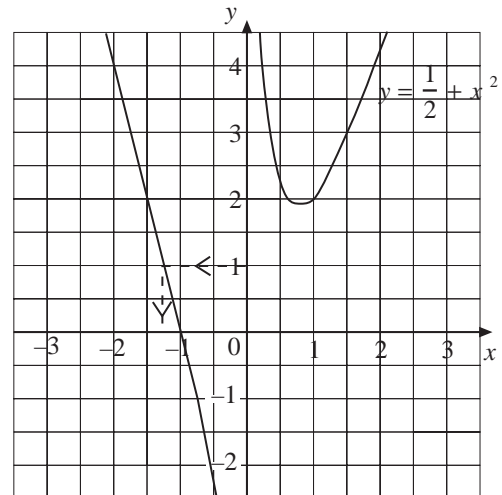

| <i>Trial x</i> | $\frac{1}{x} + x^2$ | <i>Comment</i> |
|----------------|---------------------|----------------------|
| -1 | 0 | $x < -1$ |
| -2 | 3.5 | $-2 < x < -1$ |
| -1.3 | 0.92076923 | $-2 < x < -1.3$ |
| -1.4 | 1.24571429 | $-1.4 < x < -1.3$ |
| 1.32 | 0.98482424 | $-1.4 < x < -1.32$ |
| 1.33 | 1.0170203 | $-1.33 < x < -1.32$ |
| 1.325 | 1.00090802 | $-1.325 < x < -1.32$ |

The solution to $\frac{1}{x} + x^2 = 1$ is $x = -1.32$ (to 2 decimal places).

13.4

Answers

10. The graph shows that one solution is between $x = -1$ and -2 , another between $x = -1$ and 0 , and the other between $x = 2$ and 3 .

By trial and improvement, the complete solution to $x^3 - 4x = 2$ is $x = -1.68$, -0.54 or 2.21 (to 2 decimal places).

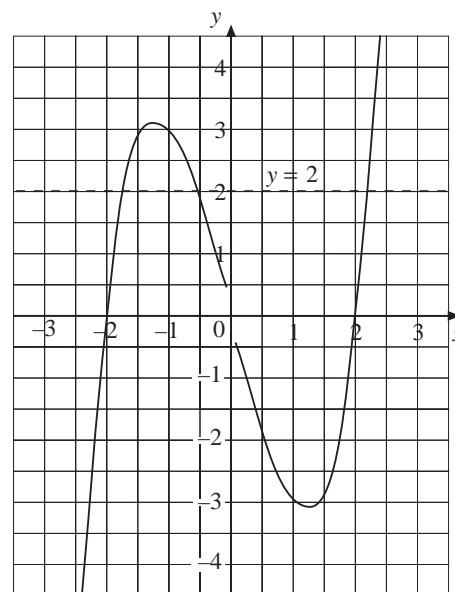

| <i>Trial x</i> | $x^3 - 4x$ | <i>Comment</i> |
|----------------|------------|----------------------|
| -1 | 3 | $x < -1$ |
| -2 | 0 | $-2 < x < -1$ |
| -1.6 | 2.304 | $-2 < x < -1.6$ |
| -1.7 | 1.887 | $-1.7 < x < -1.6$ |
| -1.67 | 2.022537 | $-1.7 < x < -1.67$ |
| -1.68 | 1.978368 | $-1.68 < x < -1.67$ |
| -1.675 | 2.00057813 | $-1.68 < x < -1.675$ |

| <i>Trial x</i> | $x^3 - 4x$ | <i>Comment</i> |
|----------------|------------|----------------------|
| 0 | 0 | $x < 0$ |
| -1 | 3 | $-1 < x < 0$ |
| -0.6 | 2.184 | $-0.6 < x < 0$ |
| -0.5 | 1.875 | $-0.6 < x < -0.5$ |
| -0.54 | 2.002536 | $-0.54 < x < -0.5$ |
| -0.53 | 1.971123 | $-0.54 < x < -0.53$ |
| -0.535 | 1.98686963 | $-0.54 < x < -0.535$ |

| <i>Trial x</i> | $x^3 - 4x$ | <i>Comment</i> |
|----------------|------------|--------------------|
| 2 | 0 | $2 < x$ |
| 3 | 15 | $2 < x < 3$ |
| 2.2 | 1.848 | $2.2 < x < 3$ |
| 2.3 | 2.967 | $2.2 < x < 2.3$ |
| 2.21 | 1.953861 | $2.21 < x < 2.3$ |
| 2.22 | 2.061048 | $2.21 < x < 2.22$ |
| 2.215 | 2.00728838 | $2.21 < x < 2.215$ |

13.4

Answers

11. (a)

| | | | | | | |
|-------------------|----|----|----|----|---|---|
| x | -2 | -1 | 0 | 1 | 2 | 3 |
| $y = x^2 + x - 5$ | -3 | -5 | -5 | -3 | 1 | 7 |

(b)

| <i>Trial x</i> | $x^2 + x - 5$ | <i>Comment</i> |
|----------------|---------------|------------------|
| 1 | -3 | $1 < x$ |
| 2 | 1 | $1 < x < 2$ |
| 1.6 | -0.84 | $1.6 < x < 2$ |
| 1.7 | -0.41 | $1.7 < x < 2$ |
| 1.8 | 0.04 | $1.7 < x < 1.8$ |
| 1.75 | -0.1875 | $1.75 < x < 1.8$ |

So the solution to $x^2 + x - 5 = 0$ is $x = 1.8$ (to 1 d.p.).

12. (a) There is a root between $x = 0$ and $x = 1$ because the difference is positive when $x = 0$ and it is negative when $x = 1$.

(b) The root lies between $x = 0.5$ and $x = 0.6$.

(c)

| x | $2x^2$ | $10x - 5$ | <i>Difference</i> |
|------|--------|-----------|-------------------|
| 0.54 | 0.5832 | 0.4 | 0.1832 |
| 0.55 | 0.605 | 0.5 | 0.105 |
| 0.56 | 0.6272 | 0.6 | 0.0272 |
| 0.57 | 0.6498 | 0.7 | -0.0502 |
| 0.58 | 0.6728 | 0.8 | -0.1272 |

So the solution to $2x^2 = 10x - 5$ lies between $x = 0.56$ and $x = 0.57$.

13. (a) The solutions to $x^2 + 4x - 2 = 0$ are $x = -4.5$ and $x = 0.5$.

(b) Any equation of the form $x^2 + 4x + k = 0$ where $k \leq 4$.

(c) $x^2 + 4x + 5 = 0$ is equivalent to the equation $x^2 + 4x = -5$, which has no solution because the curve $y = x^2 + 4x$ does not meet the line $y = -5$.

(d) $x^2 + 4x = 2 \Rightarrow x(x + 4) = 2 \Rightarrow x = \frac{2}{x + 4}$

\therefore the values of the iterative equation $x_{n+1} = \frac{2}{x_n + 4}$ should approach a solution of the equation $x^2 + 4x = 2$.

(e) $x_2 = -2$ $x_3 = -5$ $x_4 = -4.4$ $x_5 = -4.45454545$

13.5

Answers

13.5 Quadratic Inequalities

1.

(b) $x \leq -3$ or $x \geq 1$

(c) $-3 < x < 1$

2.

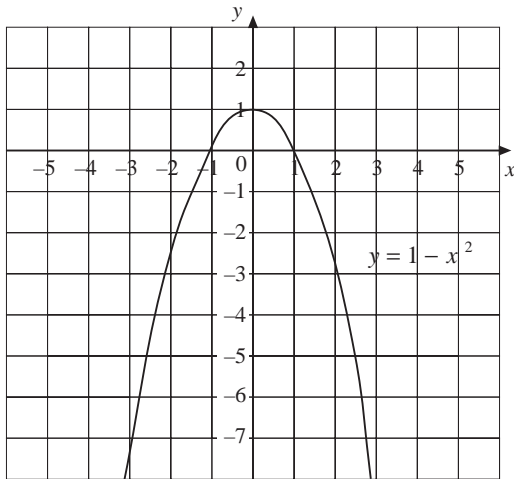

(a)

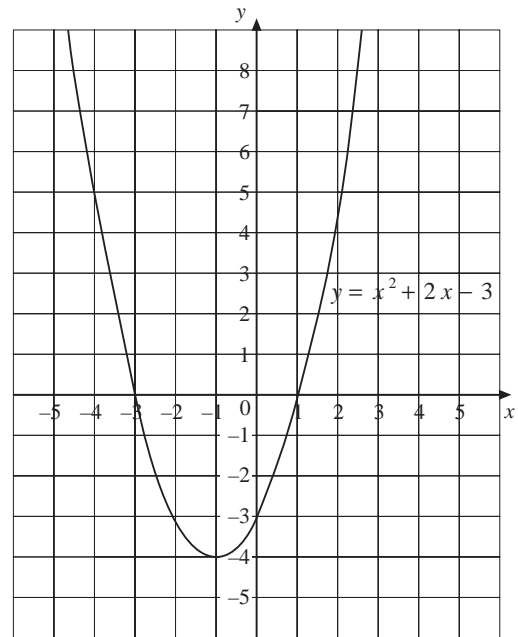

The solution is $x < -1$ or $x > 1$.

3.

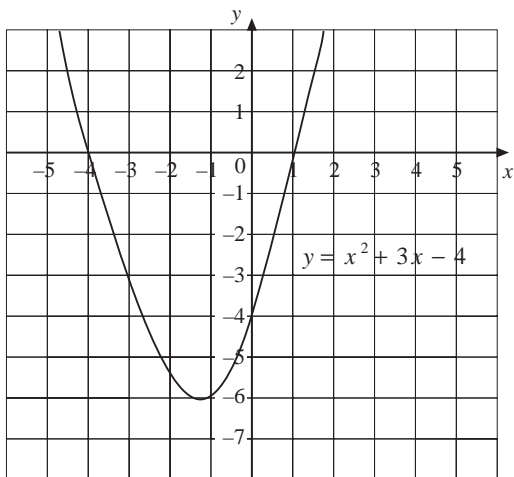

The solution is $-4 \leq x \leq 1$.

4. (a) $x^2 - 5x = x(x - 5)$

(c) The solution is $0 < x < 5$.

5. (a) $x < -5$ or $x > 0$ (b) $0 \leq x \leq 3$

(c) $x < 0$ or $x > 1$ (d) $0 \leq x \leq 2$

(b)

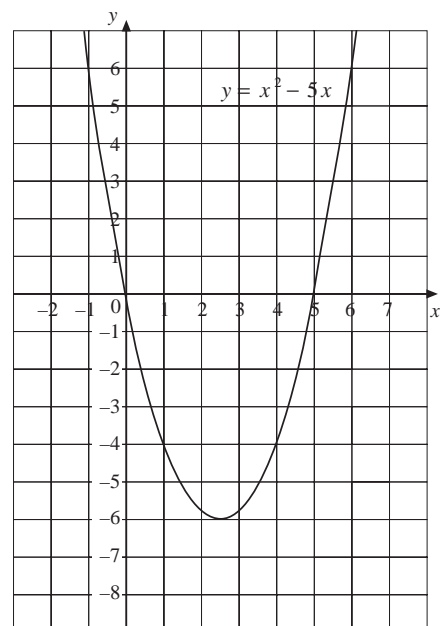

13.5

Answers

6. (a) $x^2 - 49 = (x - 7)(x + 7)$

(c) $x < -7$ or $x > 7$

7. (a) $-6 < x < 6$

(b) $-10 \leq x \leq 10$

(c) $-4 \leq x \leq 4$

(d) $x < -9$ or $x > 9$

8. (a) $x^2 - 5x - 14 = (x - 7)(x + 2)$

(b)

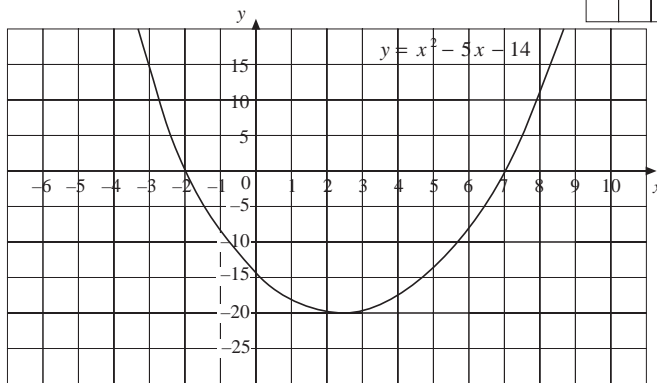
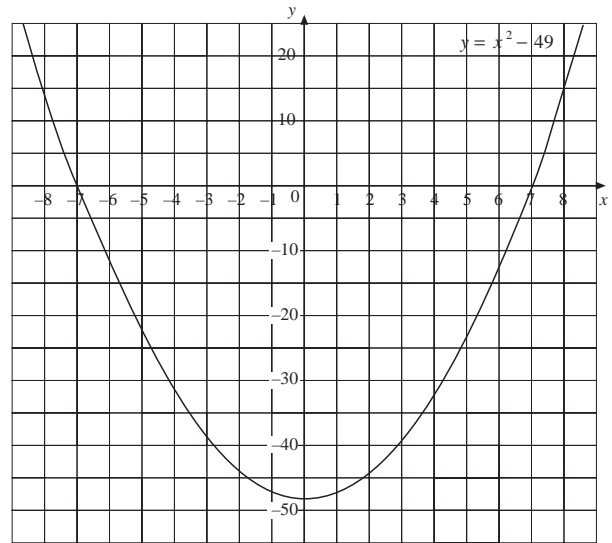

(c) $x \leq -2$ or $x \geq 7$

9. (a) $-3 < x < 9$ (b) $-4 \leq x \leq -3$

(c) $x < 5$ or $x > 8$ (d) $x \leq -2$ or $x \geq 9$

10. (a) $-x^2 + 12x - 27 = (-x + 3)(x - 9) = -(x - 3)(x - 9)$

(c) $x < 3$ or $x > 9$

11. (a)

| n | $\frac{n(n+1)}{2}$ |
|-----|--------------------|
| 22 | 253 |
| 23 | 276 |
| 24 | 300 |
| 25 | 325 |
| 26 | 351 |
| 27 | 378 |
| 28 | 406 |

(b)

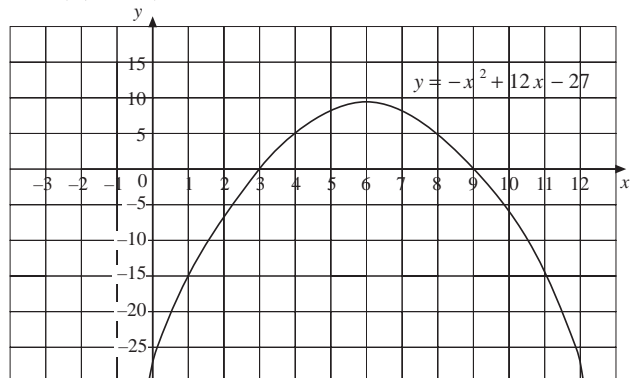

So $300 < \frac{n(n+1)}{2} < 360$ for $n = 25$ or $n = 26$, giving triangular numbers 325 and 351.

13.5

Answers

(b)

| n | $\frac{n(n+1)}{2}$ |
|-----|--------------------|
| 70 | 2485 |
| 71 | 2556 |
| 72 | 2628 |
| 73 | 2701 |
| 74 | 2775 |
| 75 | 2850 |
| 76 | 2926 |

So $2700 < \frac{n(n+1)}{2}$ for $n \geq 73$, giving the two smallest triangular numbers over 2700 as 2701 and 2775.

13.6 Equations of Perpendicular Lines

1. (a) and (c)

(b) $y = -\frac{1}{2}x$

2. (a) Lines C and E

(b) Line D

3. Gradient of AB = $\frac{1-3}{6-1} = \frac{-2}{5}$

Gradient of CD = $\frac{6-1}{5-3} = \frac{5}{2}$

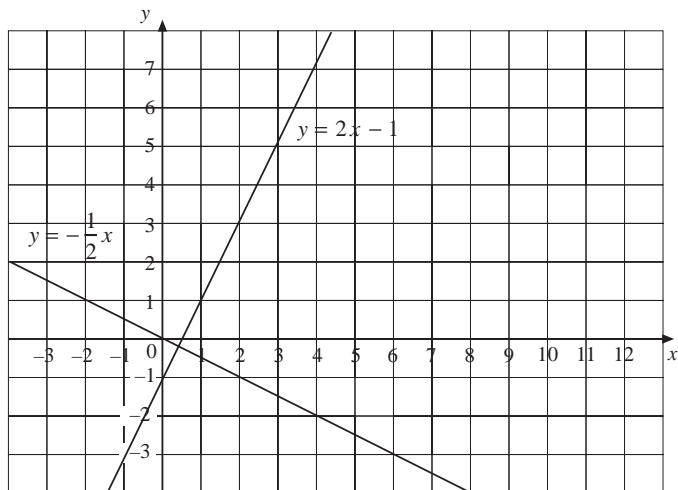

As $\frac{-1}{\left(\frac{-2}{5}\right)} = \frac{5}{2}$, it follows that AB is perpendicular to CD.

4. Gradient of QR = $\frac{5-3}{6-7} = \frac{2}{-1} = -2$ Gradient of RS = $\frac{3-5}{2-6} = \frac{-2}{-4} = \frac{1}{2}$

Gradient of ST = $\frac{1-3}{3-2} = \frac{-2}{1} = -2$ Gradient of TQ = $\frac{1-3}{3-7} = \frac{-2}{-4} = \frac{1}{2}$

∴ QR ⊥ RS ⊥ ST ⊥ TQ and QR ∥ ST and RS ∥ TQ, so QRST is a rectangle.

5. $y = x - 1$

6. Yes the lines are perpendicular because the first line has gradient = $\frac{1}{3}$, the second has gradient -3 ,

and $\frac{-1}{\left(\frac{1}{3}\right)} = -3$

13.6

Answers

-
7. (a) $y = \frac{-4}{7}x$ or $7y + 4x = 0$ (b) $y = \frac{-4}{7}x + 9\frac{2}{7}$ or $7y + 4x = 65$
8. (a) $y = 9 - 2x$ (b) $(2, 5)$
9. $y = 22 - 4x$ and $y = \frac{1}{4}x + 5$
10. The line through the origin has gradient $\frac{5}{6}$ so the perpendicular line has gradient $\frac{-6}{5}$ and equation $y = \frac{-6}{5}x + 12\frac{1}{5}$, or $5y + 6x = 61$. This second line crosses the x -axis at the point $\left(10\frac{1}{6}, 0\right)$.

Practice Book *UNIT 14 Estimation and Approximation*

Answers

14.1 Rounding

1. (a) 100 (b) 200 (c) 3500
(d) 100 (e) 0 (f) 500
2. (a) 5 000 000 (b) 4 765 170 (c) 4 765 000 (d) 4 765 200
3. (a) 37 400 (b) 84 600 (c) 261
(d) 0.368 (e) 0.00262 (f) 0.00257
(g) 3.62 (h) 4.01 (i) 18.3
4. (a) 7.43 (b) 8.27 (c) 4.71
(d) 11.93 (e) 24.86 (f) 44.00
5. (a) 6.5 (b) 1000 (c) 3700
(d) 571.3 (e) 16 000 (f) 148
(g) 17.0 (h) 39 (i) 160.4
6. (a) 183.959 (b) 184 (c) 180
(d) 183.96 (e) 184.0 (f) 200
7. (a) Barry has rounded up instead of rounding off (rounding down).
(b) He tried to round to the nearest whole number or to 3 significant figures. The correct answer should have been 374.
8. (a) 8.3 (b) 31 (c) 180
(d) 84 (e) 3300 (f) 2900
(g) 0.031 (h) 13 000 (i) 46
9. (a) This statement is correct because $47\,383.5 \text{ tonnes} \leq \text{true mass} < 47\,384.5 \text{ tonnes}$.
(b) This statement is incorrect; for example, the mass might have been 47 384.3 tonnes.
10. (a) The rabbit has mass 1500 grams (to the nearest 100 grams).
(b) The rabbit has mass 1470 grams (to the nearest 10 grams).
(c) The rabbit has mass 1 kg (to the nearest kg).
11. (a) The measured length of 35.42 m means that
 $35.415 \text{ m} \leq \text{Viv's best throw} < 35.425 \text{ m}$
so the throw could have been more than 35.42 m; for example, it might have been 35.423 m.
(b) $14.55 \text{ seconds} \leq \text{actual value} < 14.65 \text{ seconds}$
12. (a) (i)

| <i>River</i> | <i>Length in km to the nearest km</i> | <i>Length in km to the nearest 100 km</i> |
|--------------|---------------------------------------|---|
| Severn | 354 | 400 |
| Thames | 346 | 300 |
| Trent | 297 | 300 |
| Wye | 215 | 200 |
| Dee | 113 | 100 |

14.1

Answers

(ii) Thames and Trent

| (b) (i) | <i>River</i> | <i>Length in km to the nearest km</i> | <i>Length in km to the nearest 10 km</i> |
|---------|--------------|---------------------------------------|--|
| | Severn | 354 | 350 |
| | Thames | 346 | 350 |
| | Trent | 297 | 300 |
| | Wye | 215 | 220 |
| | Dee | 113 | 110 |

(ii) Severn and Thames

(c) This statement can be completed with any value in the range

$$150 \text{ km} \leq \text{river length} < 155 \text{ km}$$

(d) This statement can be completed with any pair of values, one from each of the ranges

$$250 \text{ km} \leq \text{river length} < 255 \text{ km}$$

$$245 \text{ km} \leq \text{river length} < 250 \text{ km}$$

13. (a) 20.5 cm (b) A = 20.5 cm B = 21.5 cm

(c) C = 20.45 cm D = 20.5 cm E = 20.55 cm

(d) You cannot be sure the card will fit in the envelope.

This is because the maximum possible card length (20.55 cm) is larger than the smallest possible envelope length (20.5 cm). For example, a card of length 20.53 cm would not fit in an envelope of length 20.52 cm.

14.2 Estimation

1. For example,

(a) $3.6 \times 14.3 \approx 4 \times 10 = 40$ or $3.6 \times 14.3 \approx 4 \times 14 = 56$

(b) $47 \times 192 \approx 50 \times 200 = 10000$ or $47 \times 192 \approx 47 \times 200 = 9400$

(c) $33.6 \times 403 \approx 30 \times 400 = 12000$ or $33.6 \times 403 \approx 34 \times 400 = 13600$

(d) $11.25 \times 76.3 \approx 10 \times 80 = 800$ or $11.25 \times 76.3 \approx 11 \times 80 = 880$

(e) $12.84 \times 3.94 \approx 10 \times 4 = 40$ or $12.84 \times 3.94 \approx 12 \times 4 = 48$

(f) $103.6 \div 21.72 \approx 100 \div 20 = 5$ or $103.6 \div 21.72 \approx 100 \div 25 = 4$

(g) $44.32 \div 1.987 \approx 40 \div 2 = 20$ or $44.32 \div 1.987 \approx 44 \div 2 = 22$

(h) $68.39 \div 7.48 \approx 70 \div 7 = 10$ or $68.39 \div 7.48 \approx 72 \div 8 = 9$

(i) $12.021 \div 5.917 \approx 12 \div 6 = 2$ or $12.021 \div 5.917 \approx 10 \div 5 = 2$

2. (a) $\sqrt{\frac{3.9 \times 17.45}{4.23}} \approx \sqrt{\frac{4 \times 16}{4}} = \sqrt{16} = 4$

(b) $\sqrt{8.1^2 + 7.32^2} \approx \sqrt{8^2 + 6^2} = \sqrt{100} = 10$

or $\sqrt{8.1^2 + 7.32^2} \approx \sqrt{8^2 + 7^2} = \sqrt{113} \approx \sqrt{121} = 11$

14.2

Answers

$$(c) \quad \sqrt{\frac{62.4 \times 18.3}{4.7}} \approx \sqrt{\frac{64 \times 20}{5}} = \sqrt{64 \times 4} = 8 \times 2 = 16$$

$$(d) \quad \sqrt{\frac{11.42 \times 19.99}{3.851}} \approx \sqrt{\frac{9 \times 16}{4}} = \sqrt{36} = 6$$

$$\text{or } \sqrt{\frac{11.42 \times 19.99}{3.851}} \approx \sqrt{\frac{10 \times 20}{4}} = \sqrt{50} \approx \sqrt{49} = 7$$

3. (a) $14.62 \times 401 \approx 10 \times 400 = 4000$ or $14.62 \times 401 \approx 15 \times 400 = 6000$
means that James' answer is approximately one tenth of the correct value.
- (b) $14.62 \times 401 = 5862.62$, so James has put the decimal point in the wrong place.
4. (a) This calculation is incorrect because $15.2 \times 6120 \approx 15 \times 6000 = 90\,000$, which is not approximately 930 240.
- (b) This calculation may be correct because $65.224 \div 12.4 \approx 60 \div 12 = 5$, which is approximately 5.26.
- (c) This calculation may be correct because $192 \times 4587 \approx 200 \times 4600 = 920\,000$, which is approximately 880 704.
- (d) This calculation is incorrect because $346.92 \div 2.36 \approx 350 \div 2 = 175$, which is not approximately 14.7.
5. (a) $3.712 \times 805 \approx 4 \times 800 = 3200$, so the correct answer must be 2988.16
- (b) $2955.82 \div 9.82 \approx 3000 \div 10 = 300$, so the correct answer must be 301
- (c) $\sqrt{\frac{7.2^2 + 8.1^2}{4}} \approx \sqrt{\frac{6^2 + 8^2}{4}} = \sqrt{\frac{100}{4}} = \sqrt{25} = 5$, so the correct answer must be 5.4187
- (d) $\frac{84.2 + 73.6}{2.2} \approx \frac{80 + 70}{2} = \frac{150}{2} = 75$, so the correct answer must be 71.73
6. Number of seconds in December = $31 \times 24 \times 60 \times 60$
 $\approx 30 \times 20 \times 60 \times 60$
 $= 600 \times 3600$
 $\approx 600 \times 4000$
 $= 2\,400\,000$
- The correct number of seconds in December = $31 \times 24 \times 60 \times 60 = 2\,678\,400$
7. Circumference = $2 \times \pi \times 20.5 \approx 2 \times 3 \times 20 = 120$ cm
8. Number of words in book = $326 \times 268.4 \approx 300 \times 300 = 90\,000$ words
9. Total spent in canteen = $1264 \times \text{£}1.42 \approx 1200 \times \text{£}1.50 = \text{£}1800$
10. Circumference = $\pi \times 6.27^2 \approx 3 \times 6^2 = 3 \times 36 = 108$ cm²

14.2

Answers

11. (a) Temperature in degrees Fahrenheit = $(320 - 32) \times 5 \div 9$
 $= 288 \times 5 \div 9 = 1440 \div 9 = 160 \text{ }^\circ\text{F}$

- (b) *Egg Custard with Raisins*
 About 100 grams of raisins
 About 0.5 litres of milk
 3 eggs
 Put the raisins in a 20 centimetre bowl.

14.3 Calculator Use

1. (a) $1.182781457 = 1.2$ (to 2 s.f.) (b) $1.96744186 = 2.0$ (to 2 s.f.)
 (c) $15.21875 = 15$ (to 2 s.f.) (d) $4.240766074 = 4.2$ (to 2 s.f.)
 (e) $1.607954545 = 1.6$ (to 2 s.f.) (f) $1.025385764 = 1.0$ (to 2 s.f.)
 (g) $\frac{4.3 \times 3.07 \times 6.109}{2.9 \times 9.81 \times 5.006} = 0.566264199 = 0.57$ (to 2 s.f.) (h) $1.08 = 1.1$ (to 2 s.f.)

2. (a) $8.5264 = 8.53$ (to 2 s.f.) (b) $605.495736 = 605$ (to 3 s.f.)
 (c) $3.687817783 = 3.69$ (to 3 s.f.) (d) $31.7289 = 31.7$ (to 3 s.f.)
 (e) $237.1748 = 237$ (to 3 s.f.) (f) $130.12 = 130$ (to 3 s.f.)

3. (a) $\frac{81.4}{12 - 3.2} \approx \frac{81}{9} = 9$ or $\frac{81.4}{12 - 3.2} \approx \frac{80}{8} = 10$

The correct answer = 9.25 (to 3 s.f.)

(b) $\frac{33.6}{4.52} - \frac{11.2}{21.5} \approx \frac{35}{5} - \frac{10}{20} = 7 - 0.5 = 6.5$

The correct answer = 6.912698086 = 6.91 (to 3 s.f.)

(c) $\frac{88.92 - 14.37}{2.69} \approx \frac{89 - 14}{3} = \frac{75}{3} = 25$

The correct answer = 27.71375465 = 27.7 (to 3 s.f.)

(d) $\frac{84.3 + 18.92}{3(4.6 - 0.17)} \approx \frac{80 + 20}{3 \times 5} = \frac{100}{15} = \frac{20}{3} \approx \frac{21}{3} = 7$

The correct answer = 7.766741911 = 7.77 (to 3 s.f.)

4. (a) $\frac{3.7 + 8.9}{4.61} \approx \frac{4 + 9}{5} = \frac{13}{5} \approx \frac{15}{5} = 3$ so Joseph has the incorrect answer.

(b) Joseph calculated $3.7 + \frac{8.9}{4.61}$

(c) $\frac{3.7 + 8.9}{4.61} = \frac{12.6}{4.61} \approx 2.73318872 = 2.73$ (to 3 s.f.)

14.3

Answers

5. (a) Dee obtains $2.19047619 = 2.19$ (to 3 s.f.).
Daniella obtains $2.571428571 = 2.57$ (to 3 s.f.)
- (b) Dee has calculated $\left(\frac{4}{7} + 6\right) \div 3$
- (c) Daniella has calculated $\frac{4}{7} + \frac{6}{3}$
6. (a) 2 hours 20 minutes $\approx 2\frac{1}{2}$ hours $= 2\frac{1}{2} \times 60$ minutes
 $= 150$ minutes $= 150 \times 60$ seconds
 $= 9000$ seconds
which is not close to Adrian's estimate of 2520 seconds.
- (b) In attempting to calculate $(2 \times 60 + 20) \times 60$
Adrian calculated $(2 \times 20 + 2) \times 60$
Richard calculated $2 \times (60 + 20) \times 60$
7. Denise is correct. Scientific calculators incorporate the BODMAS rule, so will divide 3.6 by 17.2, and 8.6 by 3.5, then add the results together, as required.
8. (a), (b) and (d) can be calculated without using brackets or memory.
(c), (e) and (f) all require either brackets or a memory to get the correct answer.
9. (a) $\sqrt{\frac{3.7}{0.84}} \approx \sqrt{\frac{4}{1}} = \sqrt{4} = 2$
The correct answer $= 2.098752464 = 2.10$ (to 3 s.f.)
- (b) $\sqrt{\frac{8.2}{1.6}} + \sqrt{\frac{9.2}{1.3}} \approx \sqrt{\frac{8}{2}} + \sqrt{\frac{9}{1}} = \sqrt{4} + \sqrt{9} = 2 + 3 = 5$
The correct answer $= 4.924094972 = 4.92$ (to 3 s.f.)
- (c) $\sqrt{8.4^2 + 4.8^2 - 2 \times 8.4 \times 4.8} \approx \sqrt{8^2 + 5^2 - 2 \times 8 \times 5} = \sqrt{64 + 25 - 80} = \sqrt{9} = 3$
The correct answer $= 3.6$
- (d) $\frac{\sqrt{82} - \sqrt{63}}{\sqrt{47} \times \sqrt{32}} \approx \frac{\sqrt{81} - \sqrt{64}}{\sqrt{49} \times \sqrt{36}} \approx \frac{9 - 8}{7 \times 6} = \frac{1}{42} \approx \frac{1}{40} = 0.025$
The correct answer $= 0.028831607 = 0.0288$ (to 3 s.f.)
10. (a) $\{[(3 \times 24) + 4] \times 60 + 28.5\} \times 60$ (b) 275 310 seconds
11. (a) 0.00529 mm (b) 52 white cells

14.3

Answers

12. (a) 0.618033988
 (b) There are a number of possible solutions, depending on the type of calculator being used. Some possible answers include:

$$\boxed{2} \boxed{\div} \boxed{(} \boxed{1} \boxed{+} \boxed{\sqrt{}} \boxed{5} \boxed{)} \boxed{=}$$

$$\boxed{2} \boxed{\div} \boxed{(} \boxed{1} \boxed{+} \boxed{5} \boxed{\sqrt{}} \boxed{)} \boxed{=}$$

$$\boxed{1} \boxed{+} \boxed{\sqrt{}} \boxed{5} \boxed{=} \boxed{\text{Min}} \boxed{2} \boxed{\div} \boxed{\text{MR}} \boxed{=}$$

- (c) 0.381966011
 (d) Again there are a number of possible solutions, depending on the type of calculator being used. Some possible answers include:

$$\boxed{2} \boxed{\div} \boxed{(} \boxed{1} \boxed{+} \boxed{\sqrt{}} \boxed{5} \boxed{)} \boxed{=} \boxed{x^2}$$

$$\boxed{1} \boxed{+} \boxed{\sqrt{}} \boxed{5} \boxed{=} \boxed{\text{Min}} \boxed{2} \boxed{\div} \boxed{\text{MR}} \boxed{=} \boxed{x^2}$$

14.4 Error Propagation

1. (a) $190 \text{ m} \leq \text{perimeter} < 194 \text{ m}$ (b) $2256.25 \text{ m}^2 \leq \text{area} < 2352.25 \text{ m}^2$
2. $226.9800692 \text{ cm}^2 \leq \text{area} < 283.528737 \text{ cm}^2$
 i.e. $226.98 \text{ cm}^2 \leq \text{area} < 283.53 \text{ cm}^2$ (to 2 d.p.)
3. (a) $7.38 \text{ m} \leq \text{perimeter} < 7.42 \text{ m}$ (b) $3.067625 \text{ m}^2 \leq \text{area} < 3.104625 \text{ m}^2$
4. $22\,449.2975 \text{ cm}^3 \leq \text{volume} < 26\,521.84878 \text{ cm}^3$
 i.e. $22\,449.30 \text{ cm}^3 \leq \text{volume} < 26\,521.85 \text{ cm}^3$ (to 2 d.p.)
5. (a) $26.5225 \leq x^2 < 27.5625$ (b) $16.7 \leq x + y < 16.9$
 (c) $59.4825 \leq xy < 61.1625$ (d) $6.3 \leq y - x < 6.5$
 (e) $159.925 \leq x^2 + y^2 < 163.285$ (f) $0.442060085 \leq \frac{x}{y} < 454545454$
6. (a) 40 cm (b) 96.9375 cm^2
7. (a) Maximum possible radius = 18.5 m
 (b) $109.9557429 \text{ m} \leq \text{circumference} < 116.2389282 \text{ m}$
 i.e. $109.96 \text{ m} \leq \text{circumference} < 116.24 \text{ m}$ (to 2 d.p.)
 so circumference = $113.10 \text{ m} \pm 3.14 \text{ m}$ (to 2 d.p.)
8. (a) Perimeter = $7.2 \text{ cm} \pm 0.2 \text{ cm}$
 (b) $3.0625 \text{ cm}^2 \leq \text{area} < 3.4225 \text{ cm}^2$
 $\therefore a = \text{the average of } 3.0625 \text{ and } 3.4225 = 3.2425$
 and $b = 3.4225 - 3.2425 = 0.18$
 so area = $3.2425 \text{ m}^2 \pm 0.18 \text{ m}^2$

14.4

Answers

9. $3.674234614 \text{ m} \leq \text{side of square} < 3.807886553 \text{ m}$
i.e. $3.67 \text{ m} \leq \text{side of square} < 3.81 \text{ m}$ (to 3 s.f.)
10. $3.908820095 \text{ cm} \leq \text{radius of circle} < 4.068428945 \text{ cm}$
i.e. $3.91 \text{ cm} \leq \text{radius of circle} < 4.07 \text{ cm}$ (to 2 d.p.)
11. (a) Mary's figure means $1.65 \leq \text{mass} < 1.75$
Arvind's figure means $1.7475 \leq \text{mass} < 1.7485$
Since these intervals overlap, Mary and Arvind can both be correct (for example, if the mass was 1.7478).
- (b) Nesta's figure means $1.74735 \leq \text{mass} < 1.74745$
Arvind's figure means $1.7475 \leq \text{mass} < 1.7485$
Since these intervals do not overlap, Nesta and Arvind cannot both be correct.
- (c) Mary's figure means $2.55 \leq \text{volume} < 2.65$
Arvind's figure means $2.645 \leq \text{volume} < 2.655$
 \therefore the lower bound for the volume = 2.645
the upper bound for the volume = 2.65
- (d) $0.095 \text{ kg} \leq \text{mass} < 0.105 \text{ kg}$
 $0.015 \text{ litres} \leq \text{volume} < 0.025$
 \therefore the lower bound for the density = $\frac{0.095}{0.025} = 3.8 \text{ kg/litre}$
the upper bound for the density = $\frac{0.105}{0.015} = 7 \text{ kg/litre}$
- (e) The density as calculated from the original figures is $\frac{0.10}{0.02} = 5 \text{ kg/litre}$.
- Acceptable methods are:
- $$\frac{\text{max. density} - \text{min. density}}{\text{min. density}} = \frac{7 - 3.8}{3.8} \times 100 = 84.2\% \text{ (to 1 d.p.)}$$
- $$\frac{\text{max. density} - \text{min. density}}{\text{calc. density}} = \frac{7 - 3.8}{5} \times 100 = 64\% \text{ (to 1 d.p.)}$$
- $$\frac{\text{max. density} - \text{calc. density}}{\text{calc. density}} = \frac{7 - 5}{5} \times 100 = 40\% \text{ (to 1 d.p.)}$$
- $$\frac{\text{calc. density} - \text{min. density}}{\text{min. density}} = \frac{5 - 3.8}{3.8} \times 100 = 31.6\% \text{ (to 1 d.p.)}$$
12. (a) $69.9 \text{ }^\circ\text{F} \leq \text{temperature} < 70.1 \text{ }^\circ\text{F}$
(b) $67.91 \text{ }^\circ\text{F} \leq \text{temperature} < 68.09 \text{ }^\circ\text{F}$

14.4

Answers

(c) Using the exact formula, $30.0\text{ }^{\circ}\text{F}$ converts to $86\text{ }^{\circ}\text{F}$.

Using the approximate formula, $30.0\text{ }^{\circ}\text{F}$ converts to $90\text{ }^{\circ}\text{F}$.

$$\therefore \text{the percentage error} = \frac{90 - 86}{86} \times 100 = 4.65\% \text{ (to 2 d.p.)}$$

(d) We want

$$-5\% \leq \frac{(2C + 30) - \left(\frac{9}{5}C + 32\right)}{\frac{9}{5}C + 32} \times 100 < 5\%$$

$$\text{i.e. } -0.05(1.8C + 32) \leq 0.2C - 2 < 0.05(1.8C + 32)$$

$$\text{i.e. } -0.09C - 1.6 \leq 0.2C - 2 < 0.09C + 1.6$$

$$\text{i.e. } 0.4 \leq 0.29C \text{ and } 0.11C < 3.6$$

$$\text{i.e. } 1.379310345 \leq C < 32.7272727272$$

$$\text{i.e. } 1.4 \leq C < 32.7 \text{ (to 1 d.p.)}$$

Practice Book *UNIT 15 Trigonometry*

Answers

15.1 Pythagoras' Theorem

- (a) 10 cm (b) 20.40 cm (c) 12.04 cm (d) 20.25 cm
- (a) 4.47 cm (b) 8.72 m (c) 7.94 m (d) 9.64 m
- (a) $AB = 9$ cm (b) $EF = 9.1$ m (c) $GH = 100$ km (d) $JK = 36$ m
- (a) and (c) are the only right-angled triangles.
- 141 m (to the nearest m) or 140 m (to the nearest 10 m)
- 25.8 cm (to the nearest mm)
- (a) 2.01 m (to the nearest cm) (b) 2.02 m (to the nearest cm)
- Perimeter = 44 cm Area = 84 cm^2
- 8.66 m (to the nearest cm) or 8.70 m (to the nearest 10 cm)
- 4.58 m (to the nearest cm) or 4.60 m (to the nearest 10 cm)
- $AC = \sqrt{700} + \sqrt{5500} = 26.45751311 + 74.16198487$
 $= 100.619498 \text{ cm} = 101 \text{ cm}$ (to the nearest cm)
- $AC^2 = 7.5^2 + 4.8^2 = 56.25 + 23.04 = 79.29$
 $\therefore AC = \sqrt{79.29} = 8.904493248 \text{ km} = 8.90 \text{ km}$ (to 3 significant figures)
- (a) $(\text{Length of strut})^2 = 150^2 + 190^2 = 22500 + 36100 = 58600$
 $\therefore \text{length of strut} = \sqrt{58600} = 242.0743687 \text{ cm}$
 $= 242 \text{ cm}$ (to the nearest cm)
 (b) $(\text{Diagonal of rectangle})^2 = 150^2 + 80^2 = 22500 + 6400 = 28900$
 $\therefore \text{diagonal of rectangle} = \sqrt{28900} = 170 \text{ cm}$
 Since $170 \text{ cm} > 165 \text{ cm}$, i.e. diagonal of rectangle $>$ width of room, the room is not wide enough for the cupboard to be moved to its new position.

15.2 Trigonometric Functions

- (a) Pupils' own constructions. (b) Answers should be approximately 0.87.
 (c) Answers should be approximately 0.5. (d) Answers should be approximately 1.73.
- (a) Pupils' own constructions.
 (b) Answers should be approximately (i) 0.64 (ii) 0.77 (iii) 1.19
- (a) Pupils' own constructions.
 (b) $\sin 45^\circ = \cos 45^\circ$ because the triangle is isosceles so the opposite and adjacent have the same length. This means that $\tan 45^\circ = 1$.

15.2

Answers

4. (a) Pupils' own constructions.

Their values, rounded to 2 significant figures, should be close to the answers for part (b) as given below:

(b)

| Angle | sine | cosine | tangent |
|-------|------|--------|---------|
| 10 ° | 0.17 | 0.98 | 0.18 |
| 20 ° | 0.34 | 0.94 | 0.36 |
| 30 ° | 0.5 | 0.87 | 0.58 |
| 40 ° | 0.64 | 0.77 | 0.84 |
| 50 ° | 0.77 | 0.64 | 1.19 |
| 60 ° | 0.87 | 0.5 | 1.73 |
| 70 ° | 0.94 | 0.34 | 2.75 |
| 80 ° | 0.98 | 0.17 | 5.67 |

5. 30 °

6. 80.21218094 ° = 80 ° (to the nearest degree)

7. (a)
- $\cos \theta = 1$
- (b)
- $\sin \theta = 0$
- (c)
- $\sin 90^\circ = 1$

- (d)
- $\cos 90^\circ = 0$
- (e)
- $\tan 0^\circ = 0$
- (f) undefined (infinity)

8. (a)
- $\sin 82^\circ = 0.990$
- (b)
- $\cos 11^\circ = 0.982$
- (c)
- $\sin 42^\circ = 0.669$

- (d)
- $\tan 80^\circ = 5.67$
- (e)
- $\tan 52^\circ = 1.28$
- (f)
- $\tan 38^\circ = 0.781$

9. (a) 72.5 ° (b) 50.4 ° (c) 58.3 °

- (d) 18.1 ° (e) 27.1 ° (f) 85.0 °

10. (a) The most obvious triangle is a 6, 8, 10 right-angled triangle, but students may also come up with enlargements of this triangle.

From the triangle, $\sin \theta = 0.6$

$$\tan \theta = 0.75$$

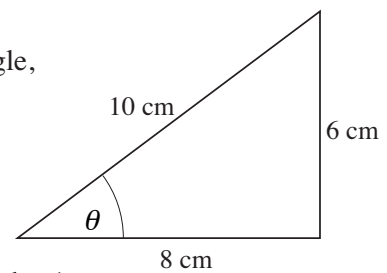

- (b)
- $\theta = \cos^{-1}(0.8) = 36.86989765^\circ = 36.9^\circ$
- (to 1 decimal place)

- (c)
- $\sin 36.86989765^\circ = 0.6$

$$\tan 36.86989765^\circ = 0.75$$

15.3

Answers

15.3 Calculating Sides

1. (a) 8.4 cm (b) 12.7 cm (c) 6.3 cm (d) 13.5 cm
2. (a) 14.2 cm (b) 12.1 cm (c) 2.2 cm (d) 29.0 cm
3. (a) $x = 12 \times \cos 50^\circ = 7.713451316 \text{ cm} = 7.71 \text{ cm (to 3 s.f.)}$
 $y = 12 \times \sin 50^\circ = 9.192533317 \text{ cm} = 9.19 \text{ cm (to 3 s.f.)}$
- (b) $a = 40 \times \cos 35^\circ = 32.76608177 \text{ m} = 32.8 \text{ m (to 3 s.f.)}$
 $b = 40 \times \sin 35^\circ = 22.94305745 \text{ m} = 22.9 \text{ m (to 3 s.f.)}$
- (c) $x = 8 \times \tan 40^\circ = 6.712797049 \text{ cm} = 6.71 \text{ cm (to 3 s.f.)}$
- (d) $p = 11 \times \tan 20^\circ = 4.003672577 \text{ cm} = 4.00 \text{ cm (to 3 s.f.)}$
- (e) $z = 9 \times \cos 25^\circ = 8.156770083 \text{ cm} = 8.16 \text{ cm (to 3 s.f.)}$
- (f) $x = 20 \times \cos 70^\circ = 6.840402866 \text{ m} = 6.84 \text{ m (to 3 s.f.)}$
4. (a) hypotenuse $= 8 \div \sin 35^\circ = 13.94757436 \text{ cm} = 13.9 \text{ cm (to 3 s.f.)}$
- (b) hypotenuse $= 3 \div \cos 70^\circ = 8.771413201 \text{ cm} = 8.77 \text{ cm (to 3 s.f.)}$
- (c) hypotenuse $= 18 \div \sin 41^\circ = 27.43655556 \text{ cm} = 27.4 \text{ cm (to 3 s.f.)}$
- (d) hypotenuse $= 33 \div \cos 42^\circ = 44.40588008 \text{ cm} = 44.4 \text{ cm (to 3 s.f.)}$
5. (a) $a = 17 \times \sin 50^\circ = 13.02275553 \text{ cm} = 13.02 \text{ cm (to 2 d.p.)}$
 $b = 17 \times \cos 50^\circ = 10.92738936 \text{ cm} = 10.9 \text{ cm (to 2 d.p.)}$
- (b) $c = 15 \div \tan 25^\circ = 32.16760381 \text{ cm} = 32.17 \text{ cm (to 2 d.p.)}$
 $d = 15 \div \sin 25^\circ = 35.49302375 \text{ cm} = 35.49 \text{ cm (to 2 d.p.)}$
- (c) $e = 14 \div \tan 12^\circ = 2.975791863 \text{ cm} = 2.98 \text{ cm (to 2 d.p.)}$
 $f = 14 \div \cos 12^\circ = 14.31276833 \text{ cm} = 14.31 \text{ cm (to 2 d.p.)}$
- (d) $g = 6 \div \tan 62^\circ = 11.28435879 \text{ cm} = 11.28 \text{ cm (to 2 d.p.)}$
 $h = 6 \div \cos 62^\circ = 12.78032681 \text{ cm} = 12.78 \text{ cm (to 2 d.p.)}$
6. (a) Distance from foot of the wall $= 6 \times \cos 65^\circ = 2.53570957 \text{ m}$
 $= 2.54 \text{ m (to the nearest cm)}$
- (b) Height of top above the ground $= 6 \times \sin 65^\circ = 5.437846722 \text{ m}$
 $= 5.44 \text{ m (to the nearest cm)}$
7. (a) Distance east $= 50 \times \sin 70^\circ = 46.98463104 \text{ km}$
 $= 47 \text{ km (to the nearest km)}$
- (b) Distance north $= 50 \times \cos 70^\circ = 17.10100717 \text{ km}$
 $= 17 \text{ km (to the nearest km)}$

15.3

Answers

8. Perimeter = $15 + (15 \times \sin 20^\circ) + (15 \times \cos 20^\circ)$
 $= 34.22569146 \text{ cm} = 34.23 \text{ cm (to 2 d.p.)}$
 Area = $(15 \times \sin 20^\circ) \times (15 \times \cos 20^\circ) \div 2$
 $= 36.15680304 \text{ cm}^2 = 36.16 \text{ cm}^2 \text{ (to 2 d.p.)}$
9. Height of top of ramp = $6 \times \sin 50^\circ = 4.596266659 \text{ m}$
 $= 4.60 \text{ m (to the nearest cm)}$
10. (a) Length of rope = $6 \div \sin 19^\circ = 18.42932092 \text{ m}$
 $= 18.43 \text{ m (to the nearest cm)}$
 (b) Height of window = $6 \tan 19^\circ = 17.42526527 \text{ m}$
 $= 17.43 \text{ m (to the nearest cm)}$

15.4 Calculating Angles

1. (a) 53.1° (b) 60° (c) 45°
 (d) 17.5° (e) 90° (f) 85.9°
2. (a) 72.6° (b) 30.4° (c) 35.5° (d) 43.5°
3. (a) $\theta = \sin^{-1}(0.7) = 44.427004^\circ = 44.4^\circ \text{ (to 1 d.p.)}$
 (b) $\theta = \cos^{-1}(0.8) = 36.86989765^\circ = 36.9^\circ \text{ (to 1 d.p.)}$
 (c) $\theta = \sin^{-1}(0.954545454) = 17.3414428^\circ = 17.3^\circ \text{ (to 1 d.p.)}$
 (d) $\theta = \sin^{-1}(0.588235294) = 36.03187907^\circ = 36.0^\circ \text{ (to 1 d.p.)}$
4. (a) $\theta = \sin^{-1}(0.7) = 44.427004^\circ = 44.4^\circ \text{ (to 1 d.p.)}$
 (b) $\theta = \tan^{-1}(0.875) = 41.18592517^\circ = 41.2^\circ \text{ (to 1 d.p.)}$
 (c) $\theta = \cos^{-1}(0.666666666) = 48.1896851^\circ = 48.2^\circ \text{ (to 1 d.p.)}$
 (d) $\theta = \tan^{-1}(3) = 71.56505118^\circ = 71.6^\circ \text{ (to 1 d.p.)}$
5. 37° , 53° and 90°
6. Angle of slope = $\tan^{-1}(0.147058823) = 8.365886124^\circ$
 $= 8^\circ \text{ (to the nearest degree)}$
7. Angle with ground = $\cos^{-1}(0.5) = 60^\circ$

15.4

Answers

8. (a) $(\text{Length of diagonal})^2 = 12^2 + 18^2 = 144 + 324 = 468$
 Length of diagonal $= \sqrt{468} = 21.63330765$ cm
 $= 21.6$ cm (to the nearest mm)
- (b) Angle between diagonal and shorter side $= \tan^{-1}(1.5)$
 $= 56.30993247^\circ = 56^\circ$ (to the nearest degree)
9. Angle between flight path and horizontal $= \sin^{-1}(0.166666666)$
 $= 9.594068227^\circ = 10^\circ$ (to the nearest degree)
10. Angle between strings $= \cos^{-1}(0.9) + \cos^{-1}(0.75)$
 $= 25.84193276^\circ + 41.40962211^\circ$
 $= 67.25155487^\circ = 67^\circ$ (to the nearest degree)
11. (a) $(\text{Height of top of ramp})^2 = 10^2 - 9.85^2 = 100 - 97.0225 = 2.9775$
 Height of top of ramp $= \sqrt{2.9775} = 1.725543393$ m > 0.83 m
 \therefore this ramp is too high.
- (b) Length of base of ramp $= 10 \times \cos 3.5^\circ = 9.981347984$ m
 $= 9.98$ m (to the nearest cm)
- (c) Recommended angle $= \tan^{-1}\left(\frac{1}{20}\right) = \tan^{-1}(0.05) = 2.862405226^\circ$
 $= 3^\circ$ (to the nearest degree)
12. (a) $(\text{Shortest distance})^2 = 6^2 + 4^2 = 36 + 16 = 52$
 Shortest distance $= \sqrt{52} = 7.211102551$ km
 $= 7.2$ km (to 1 d.p.)
- (b) Angle between direction and north $= \tan^{-1}(1.5)$
 $= 56.30993247^\circ$
 \therefore bearing $= 056^\circ$ (to the nearest degree)
- (c) $(\text{Distance west})^2 = 2.5^2 - 1.2^2 = 6.25 - 1.44 = 4.81$
 Distance west $= \sqrt{4.81} = 2.19317122$ km $= 2.2$ km (to 1 d.p.)
13. (a) Angle between direction and north $= \tan^{-1}(1.5)$
 $= 56.30993247^\circ$
 \therefore bearing $= 056^\circ$ (to the nearest degree)
- (b) Distance north of Cape Point $= 6 \div \tan 48^\circ = 5.402424266$ km
 \therefore distance north of Bargate $= 5.402424266 - 4 = 1.402424266$ km
 $= 1.40$ km (to 3 s.f.)

Practice Book *UNIT 16 Cumulative Frequency*

Answers

16.1 Averages

1. (a) Mean = 8.6 Range = 14 (b) Mean = 34.5 Range = 43
 (c) Mean = 11.8 Range = 28 (d) Mean = 118.25 Range = 23
2. (a) Median = 19 Mode = 19 (b) Median = 22 Mode = 33
 (c) Median = 8 Mode = 5 (d) Mean = 17.5 Mode = 11
3. Only in A and C are the mean and median the same.
4. Data set B has the largest range.

5. (a)

| <i>Number of Televisions</i> | <i>Frequency</i> | <i>Frequency × No. of Televisions</i> |
|------------------------------|------------------|---------------------------------------|
| 0 | 3 | 0 |
| 1 | 18 | 18 |
| 2 | 64 | 128 |
| 3 | 73 | 219 |
| 4 | 22 | 88 |
| 5 | 14 | 70 |
| 6 | 6 | 36 |
| Total | 200 | 559 |

$$\text{Mean} = \frac{559}{200} = 2.795$$

(b) Median = average of 100th and 101st values = $\frac{3 + 3}{2} = 3$

(c) Mode = 3

6. (a) Median = $\frac{556}{36} = 15.44444444 = 15.4$ (to 1 d.p.)

(b) Median = average of 18th and 19th values = $\frac{14 + 14}{2} = 14$

(c) Mode = 14 (d) Range = 41 – 3 = 38

The manager should use the mean to convince her employees that the car park is heavily used and will therefore make a large profit.

7. (a) Mean = $\pounds \frac{234.91}{8} = \pounds 29.36375 = \pounds 29.36$ (to the nearest penny)

(b) Mode = $\pounds 29.99$

(d) Median = average of 4th and 5th values = $\pounds \frac{29.95 + 29.99}{2} = \pounds 29.97$

John should use the mode (or the median) to argue that the computer game is too expensive.

8. The mean = $\frac{197}{10} = 19.7$ The median = $\frac{6 + 7}{2} = 6.5$

The advantage of using the median is that the mean is heavily influenced by the one large value, 142, making it unrepresentative of the data set as a whole.

16.1

Answers

9. (a) Mode = 2 visits to the dentist

(b)

| <i>Number of Visits</i> | <i>Frequency</i> | <i>Frequency × No. of Visits</i> |
|-------------------------|------------------|----------------------------------|
| 0 | 1 | 0 |
| 1 | 4 | 4 |
| 2 | 11 | 22 |
| 3 | 5 | 15 |
| 4 | 2 | 8 |
| 5 | 3 | 15 |
| 6 | 2 | 12 |
| 7 | 1 | 7 |
| 8 | 1 | 8 |
| Total | 30 | 91 |

The mean = $\frac{91}{30} = 3.03$ visits to the dentist.

(c) The median = average of 15th and 16th value = 2 visits to the dentist.

10. The numbers are 4, 12 and 17 (in any order).

16.2 Grouped Data

1. (a) *Frequency*

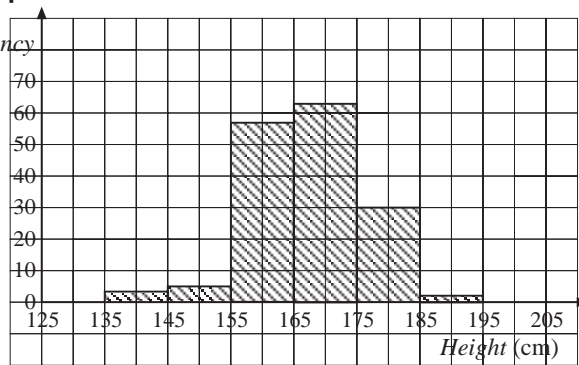

(b) Estimated mean height of the pupils = $\frac{26780}{160} = 167.375$ cm
= 167 cm (to the nearest cm)

| <i>Height (cm)</i> | <i>Class Midpoint</i> | <i>Frequency</i> | <i>Frequency × Midpoint</i> |
|----------------------|-----------------------|------------------|-----------------------------|
| 135 ≤ <i>H</i> < 145 | 140 | 3 | 420 |
| 145 ≤ <i>H</i> < 155 | 150 | 5 | 750 |
| 155 ≤ <i>H</i> < 165 | 160 | 57 | 9120 |
| 165 ≤ <i>H</i> < 175 | 170 | 63 | 10 710 |
| 175 ≤ <i>H</i> < 185 | 180 | 30 | 5400 |
| 185 ≤ <i>H</i> < 195 | 190 | 2 | 380 |
| | TOTAL | 160 | 26 780 |

16.2

Answers

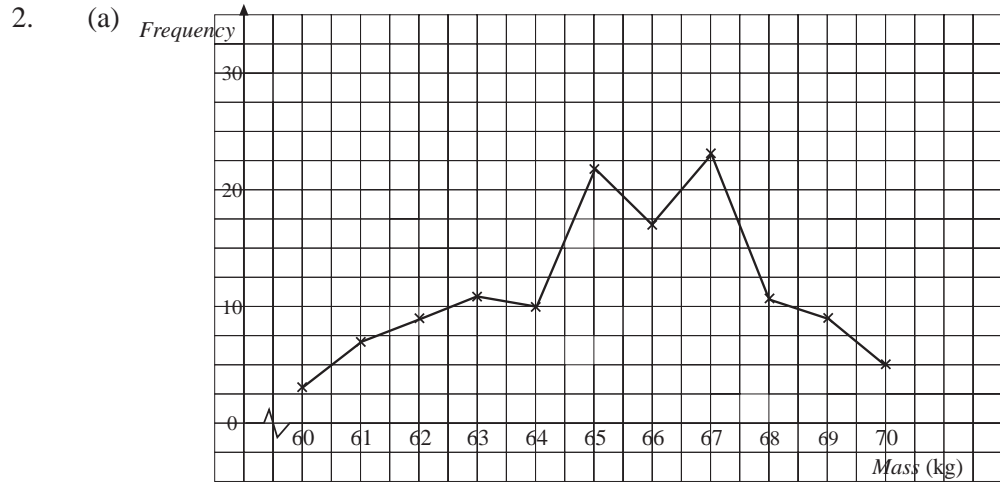

(b)

| Height (cm) | Class Midpoint | Frequency | Frequency \times Midpoint |
|----------------------|----------------|-----------|-----------------------------|
| $59.5 \leq M < 60.5$ | 60 | 3 | 180 |
| $60.5 \leq M < 61.5$ | 61 | 7 | 427 |
| $61.5 \leq M < 62.5$ | 62 | 9 | 558 |
| $62.5 \leq M < 63.5$ | 63 | 11 | 693 |
| $63.5 \leq M < 64.5$ | 64 | 10 | 640 |
| $64.5 \leq M < 65.5$ | 65 | 22 | 1430 |
| $65.5 \leq M < 66.5$ | 66 | 17 | 1122 |
| $66.5 \leq M < 67.5$ | 67 | 23 | 1541 |
| $67.5 \leq M < 68.5$ | 68 | 11 | 748 |
| $68.5 \leq M < 69.5$ | 69 | 9 | 621 |
| $69.5 \leq M < 70.5$ | 70 | 5 | 350 |
| | TOTAL | 127 | 8310 |

$$\begin{aligned} \text{Estimated mean mass of the students} &= \frac{8310}{127} = 65.43307087 \text{ kg} \\ &= 65.4 \text{ kg (to 1 d.p.)} \end{aligned}$$

3. (a)

| No. of Words | Class Midpoint | Frequency | Frequency \times Midpoint |
|------------------|----------------|-----------|-----------------------------|
| $6 \leq N < 8$ | 7 | 13 | 91 |
| $9 \leq N < 11$ | 10 | 10 | 100 |
| $12 \leq N < 14$ | 13 | 8 | 104 |
| $15 \leq N < 17$ | 16 | 4 | 64 |
| $18 \leq N < 20$ | 19 | 3 | 57 |
| | TOTAL | 38 | 416 |

16.2

Answers

$$\begin{aligned} \text{Estimated mean number of words per sentence} &= \frac{416}{38} = 10.94736842 \\ &= 11 \text{ (to the nearest integer)} \end{aligned}$$

(b) '6 - 8' is the modal class, i.e. $6 \leq \text{number of words} \leq 8$.

4. (a)

| <i>Time (min)</i> | <i>Class Midpoint</i> | <i>Frequency</i> | <i>Frequency × Midpoint</i> |
|----------------------|-----------------------|------------------|-----------------------------|
| $1.5 \leq T < 5.5$ | 3.5 | 3 | 10.5 |
| $5.5 \leq T < 9.5$ | 7.5 | 19 | 142.5 |
| $9.5 \leq T < 13.5$ | 11.5 | 20 | 230.0 |
| $13.5 \leq T < 17.5$ | 15.5 | 12 | 186.0 |
| $17.5 \leq T < 21.5$ | 19.5 | 6 | 117.0 |
| | TOTAL | 60 | 686.0 |

$$\begin{aligned} \text{Estimated mean time to solve puzzle} &= \frac{686}{60} = 11.433333333 \text{ minutes} \\ &= 11.4 \text{ minutes (to 1 d.p.)} \end{aligned}$$

5. (a) The modal class is $160 \text{ cm} \leq \text{height} < 170 \text{ cm}$.

(b)

| <i>Height (cm)</i> | <i>Class Midpoint</i> | <i>Frequency</i> | <i>Frequency × Midpoint</i> |
|--------------------|-----------------------|------------------|-----------------------------|
| $140 \leq H < 150$ | 145 | 15 | 2175 |
| $150 \leq H < 160$ | 155 | 55 | 8525 |
| $160 \leq H < 170$ | 165 | 90 | 14 850 |
| $170 \leq H < 180$ | 175 | 45 | 7875 |
| $180 \leq H < 190$ | 185 | 5 | 925 |
| | TOTAL | 210 | 34 350 |

$$\begin{aligned} \text{Estimated mean height} &= \frac{34350}{210} \\ &= 163.5714286 \text{ cm} \\ &= 163.6 \text{ cm (to 1 d.p.)} \end{aligned}$$

6.

(a)

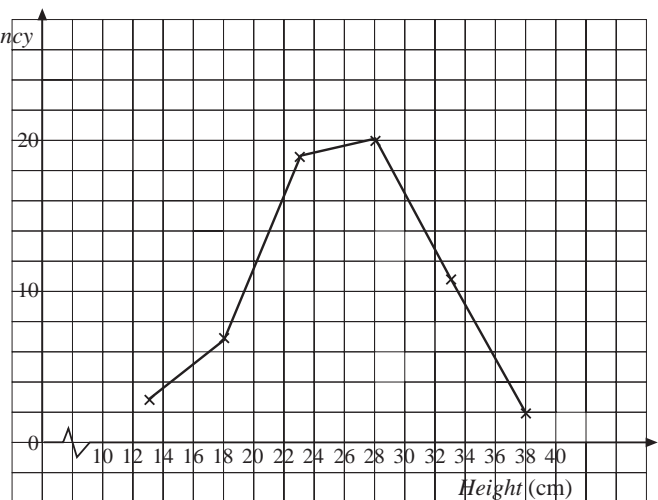

(b) '26 - 30 cm' is the modal class, i.e. $25.5 \text{ cm} \leq \text{height} < 30.5 \text{ cm}$

16.2

Answers

(c)

| <i>Height (cm)</i> | <i>Class Midpoint</i> | <i>Frequency</i> | <i>Frequency × Midpoint</i> |
|----------------------|-----------------------|------------------|-----------------------------|
| $10.5 \leq H < 15.5$ | 13 | 3 | 39 |
| $15.5 \leq H < 20.5$ | 18 | 7 | 126 |
| $20.5 \leq H < 25.5$ | 23 | 19 | 437 |
| $25.5 \leq H < 30.5$ | 28 | 20 | 560 |
| $30.5 \leq H < 35.5$ | 33 | 11 | 363 |
| $35.5 \leq H < 40.5$ | 38 | 2 | 76 |
| | TOTAL | 62 | 1601 |

$$\begin{aligned} \text{Estimated mean height} &= \frac{1602}{62} = 25.82258065 \text{ cm} \\ &= 25.8 \text{ cm (to 1 d.p.)} \end{aligned}$$

7.

| <i>Time (seconds)</i> | <i>Class Midpoint</i> | <i>Frequency</i> | <i>Frequency × Midpoint</i> |
|-----------------------|-----------------------|------------------|-----------------------------|
| $0 \leq T < 1$ | 0.5 | 0 | 0.0 |
| $1 \leq T < 2$ | 1.5 | 4 | 6.0 |
| $2 \leq T < 3$ | 2.5 | 5 | 12.5 |
| $3 \leq T < 4$ | 3.5 | 8 | 28.0 |
| $4 \leq T < 5$ | 4.5 | 7 | 31.5 |
| $5 \leq T < 6$ | 5.5 | 14 | 77.0 |
| $6 \leq T < 7$ | 6.5 | 11 | 71.5 |
| $7 \leq T < 8$ | 7.5 | 3 | 22.5 |
| $8 \leq T < 9$ | 8.5 | 2 | 17.0 |
| $9 \leq T < 10$ | 9.5 | 1 | 9.5 |
| $10 \leq T < 11$ | 10.5 | 1 | 10.5 |
| $11 \leq T < 12$ | 11.5 | 1 | 11.5 |
| $12 \leq T < 13$ | 12.5 | 0 | 0.0 |
| | TOTAL | 57 | 297.5 |

$$\text{Estimated mean time} = \frac{297.5}{57} = 5.219298246 \text{ seconds} = 5.22 \text{ seconds (to 2 d.p.)}$$

8. (a)

| <i>No. Tickets Sold</i> | <i>Class Midpoint</i> | <i>Frequency</i> | <i>Frequency × Midpoint</i> |
|-------------------------|-----------------------|------------------|-----------------------------|
| $0 \leq N \leq 10$ | 5 | 7 | 35 |
| $11 \leq N \leq 20$ | 15.5 | 42 | 651 |
| $21 \leq N \leq 50$ | 35.5 | 8 | 284 |
| $51 \leq N \leq 100$ | 75.5 | 3 | 226.5 |
| | TOTAL | 60 | 1196.5 |

16.2

Answers

$$\begin{aligned} \text{Estimated mean number of tickets sold} &= \frac{1196.5}{60} = 19.9416666667 \\ &= 20 \text{ (to the nearest integer)} \end{aligned}$$

(b) Estimated number of tickets sold = 60 pupils × 20 tickets per pupil = 1200 tickets

9.

(a)

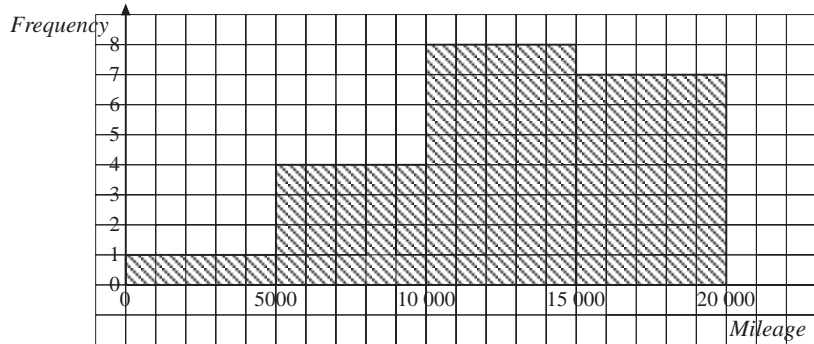

(b)

| <i>Mileage</i> | <i>Class Midpoint</i> | <i>Frequency</i> | <i>Frequency × Midpoint</i> |
|------------------------|-----------------------|------------------|-----------------------------|
| $0 \leq M < 5000$ | 2500 | 1 | 2500 |
| $5000 \leq M < 10000$ | 7500 | 4 | 30 000 |
| $10000 \leq M < 15000$ | 12 500 | 8 | 100 000 |
| $15000 \leq M < 20000$ | 17 500 | 7 | 122 500 |
| | TOTAL | 20 | 255 000 |

$$\text{Estimated mean mileage} = \frac{255\,000}{20} = 12\,750 \text{ miles}$$

10. (a)

| <i>Value</i> | <i>Class Midpoint</i> | <i>Frequency</i> | <i>Frequency × Midpoint</i> |
|------------------------|-----------------------|------------------|-----------------------------|
| $99.5 \leq V < 104.5$ | 102.0 | 5 | 510.0 |
| $104.5 \leq V < 109.5$ | 107.0 | 16 | 1712.0 |
| $109.5 \leq V < 114.5$ | 112.0 | 32 | 3584.0 |
| $114.5 \leq V < 119.5$ | 117.0 | 7 | 819.0 |
| | TOTAL | 60 | 6625.0 |

$$\text{Estimated mean value} = \frac{6625}{60} = 110.416666667 = 110.4 \text{ (to 1 d.p.)}$$

(b) Joshua obtained his lower bound by using the lower class boundaries, i.e.

$$\begin{aligned} \text{Mean} &> \frac{(5 \times 99.5) + (16 \times 104.5) + (32 \times 109.5) + (7 \times 114.5)}{60} = \frac{6475}{60} \\ &\therefore \text{mean} > 107.916666667 \qquad \therefore \text{mean} > 107.9 \text{ (to 1 d.p.)} \end{aligned}$$

(c) An upper bound can be found by using the upper class boundaries, i.e.

$$\begin{aligned} \text{Mean} &< \frac{(5 \times 104.5) + (16 \times 109.5) + (32 \times 114.5) + (7 \times 119.5)}{60} = \frac{6775}{60} \\ &\therefore \text{mean} > 112.916666667 \qquad \therefore \text{mean} < 112.9 \text{ (to 1 d.p.)} \end{aligned}$$

16.2

Answers

11. (a)

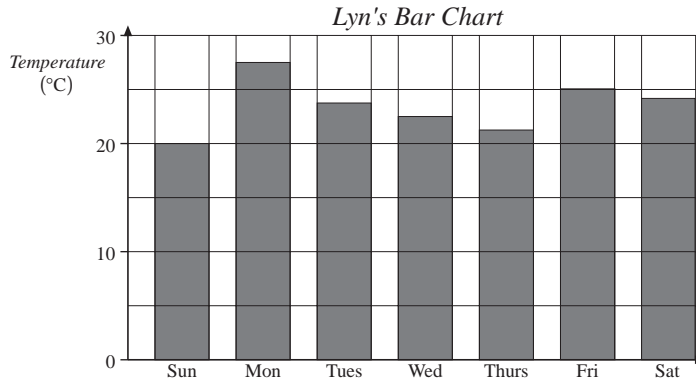

(b) Monday: 27 °C
(Allow 26 °C to 28 °C)

(c) Pupil A : Bar Chart 2
Pupil B : Bar Chart 1
Pupil C : Bar Chart 5
Pupil D : Bar Chart 3
Pupil E : Bar Chart 4

16.3 Cumulative Frequency

1. The data in order: 2, 3, 4, 5, 7, 8, 8, 9, 11, 14, 16

Median = 8 Interquartile range = 11 - 4 = 7

2. The data in order: 26, 27, 32, 32, 33, 38, 41, 42, 46, 52, 52, 53, 59, 71, 88

Semi-interquartile range = $\frac{53 - 32}{2} = 10.5$

3. IQR = 2 × 14 = 28, so LQ = 91 - 28 = 63 ∴ median = 63 + 5 = 68

4. (a)

| Time (min) | Under 0 | Under 10 | Under 20 | Under 30 | Under 40 | Under 50 |
|------------|---------|----------|----------|----------|----------|----------|
| Frequency | 0 | 3 | 10 | 20 | 35 | 39 |

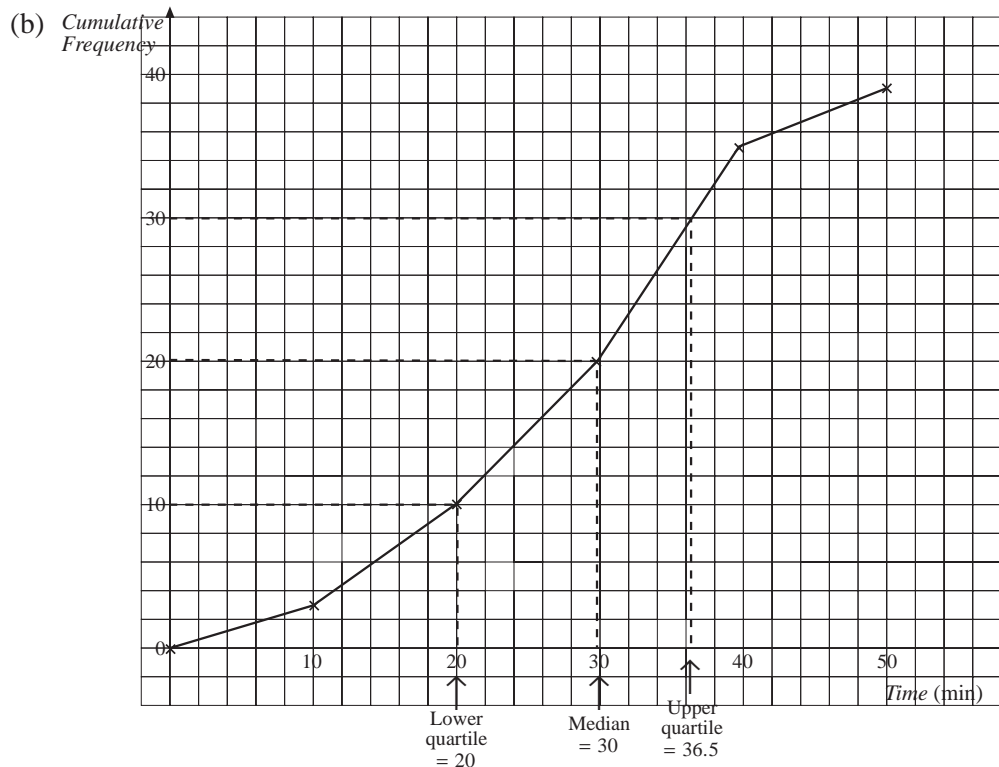

16.3

Answers

(c) Median = 30 minutes

(d) Lower quartile = 20 minutes Upper quartile = 36.7 minutes

$$\text{Semi-interquartile range} = \frac{36.7 - 20}{2} = 8.35 \text{ minutes}$$

5. Median = 14.5 cm Lower quartile = 8 cm Upper quartile 20 cm
 Interquartile range = 12 cm

6. Pupils' individual surveys and results.

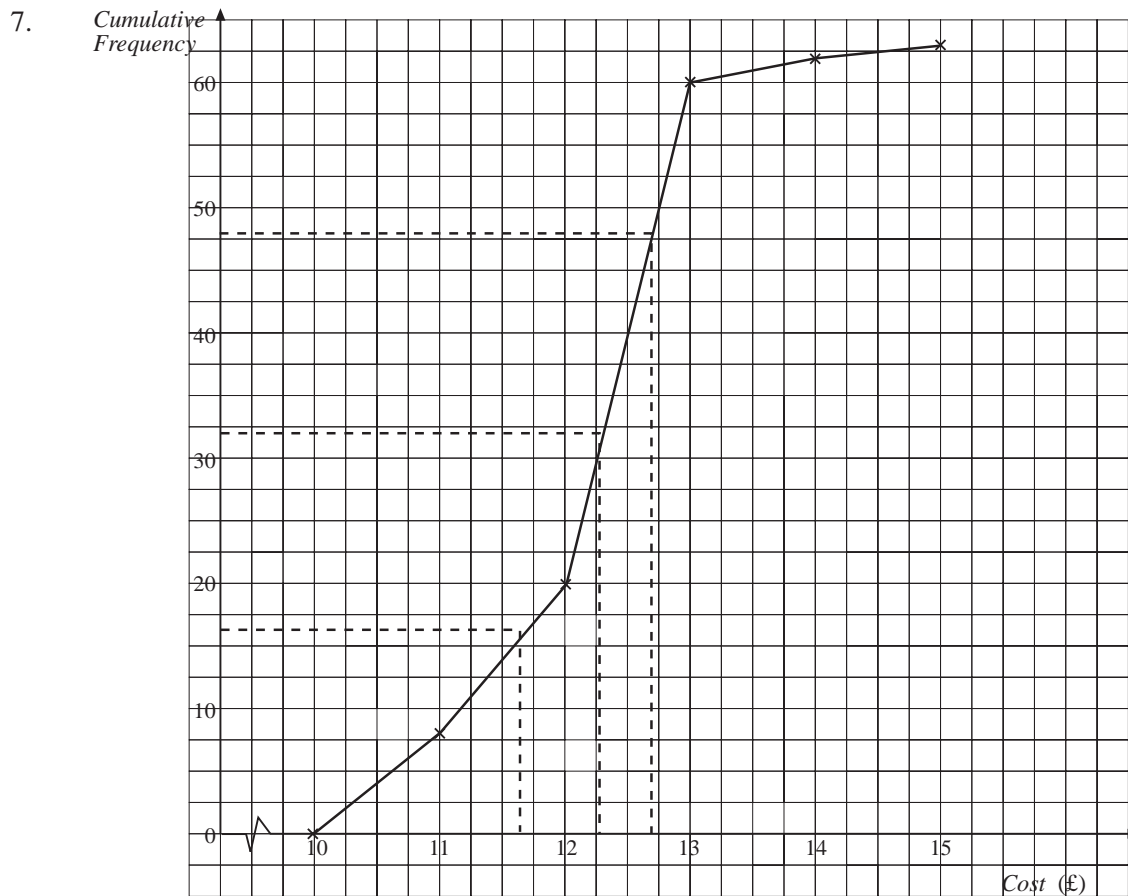

Median = £12.30

Lower quartile = £11.67 Upper quartile = £12.70

Interquartile range = £1.03

8. (a)

| <i>Time (seconds)</i> | <i>Class Midpoint</i> | <i>Frequency</i> | <i>Frequency × Midpoint</i> |
|-----------------------|-----------------------|------------------|-----------------------------|
| $0 \leq T < 10$ | 5 | 1 | 5 |
| $10 \leq T < 20$ | 15 | 2 | 30 |
| $20 \leq T < 30$ | 25 | 12 | 300 |
| $30 \leq T < 40$ | 35 | 15 | 525 |
| $40 \leq T < 50$ | 45 | 5 | 225 |
| | TOTAL | 35 | 1085 |

16.3

Answers

Estimated mean burn time = $\frac{1085}{35} = 31$ minutes.

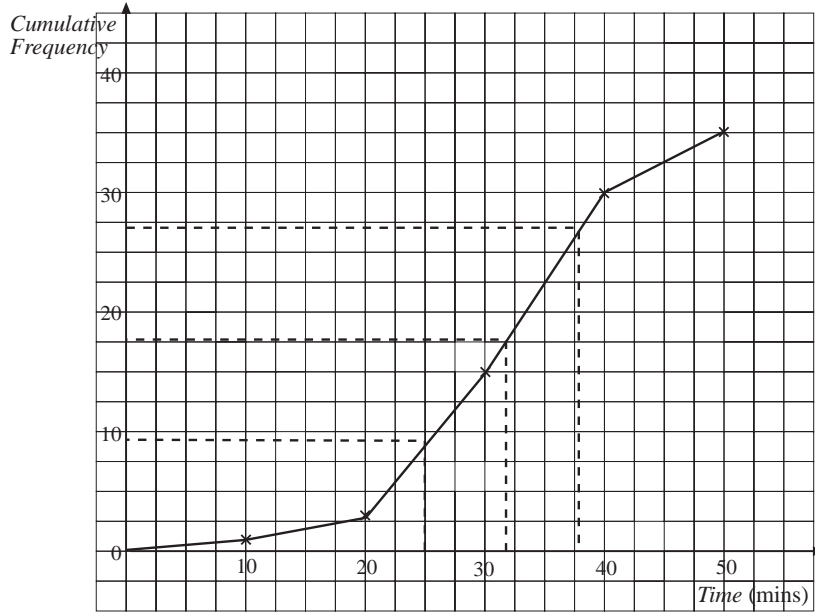

Median = 32 minutes

The median and the mean are approximately equal.

The median is 1 minute more than the mean.

- (b) Lower quartile = 25 minutes Upper quartile = 36.7 minutes

Semi-interquartile range = $\frac{38 - 25}{2} = 6.5$ minutes

9. (a)

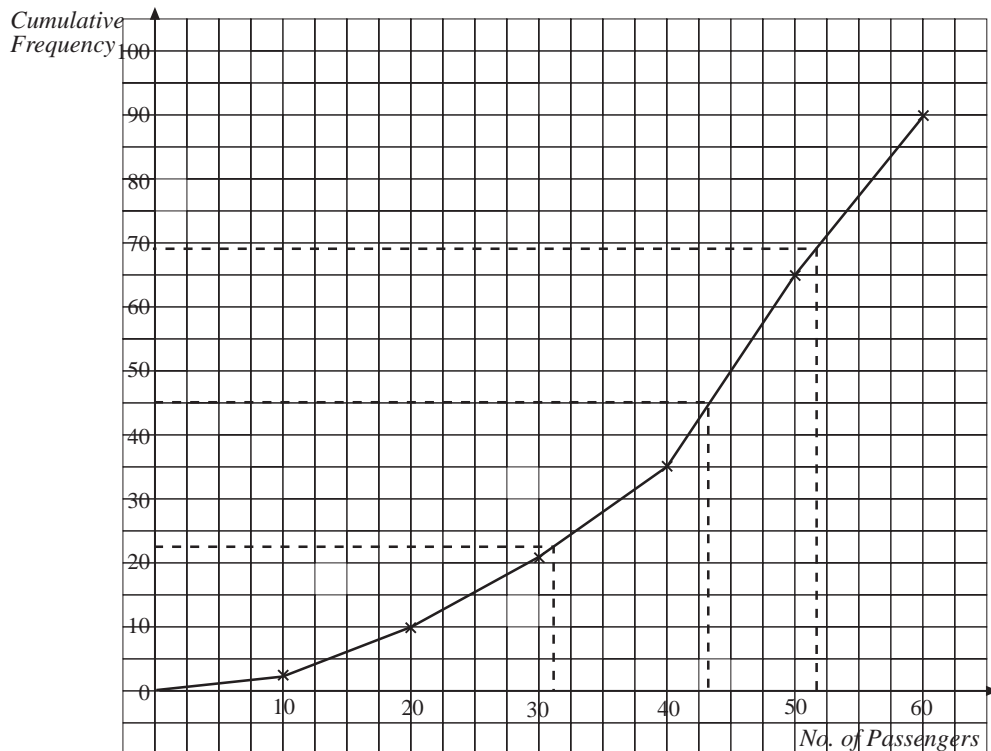

16.3

Answers

Median = 43.8 passengers = 44 passengers to the nearest integer.

(b) Lower quartile = 30.8 passengers Upper quartile = 51.9 passengers

$$\text{Semi-interquartile range} = \frac{51.9 - 30.8}{2} = 10.55 \text{ passengers}$$

= 11 passengers to the nearest integer

10. Pupils' own samples.

One possible sample is 1, 2, 3, 4, 5, 5, 6, 7, 8, 10, 11 which has

lower quartile = 3 upper quartile = 8

$$\text{Semi-interquartile range} = \frac{8 - 3}{2} = 2.5$$

$$\text{One quarter of the range} = \frac{11 - 1}{4} = 2.5$$

11. (a) Median = 0.62 m (Allow 0.62 m - 0.63 m)

Lower quartile = 0.58 m Upper quartile = 0.67 m

Interquartile range = 0.09 m (Allow 0.07 m - 0.10 m)

(b) Diagram C

12. (a) Median = £31.10 (Allow £30.560 - £32.00)

(b) Percentage = $\frac{34}{40} \times 100 = 85\%$ (Allow 82% - 87%)

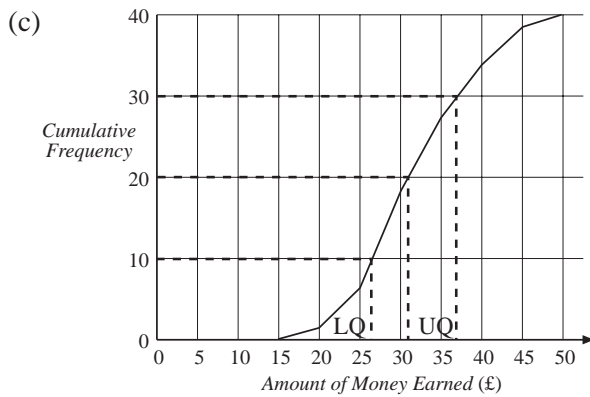

Lower quartile = £26.40
 Upper quartile = £37.10
 Interquartile range = £10.70
 (Allow £9.50 - £11.50)

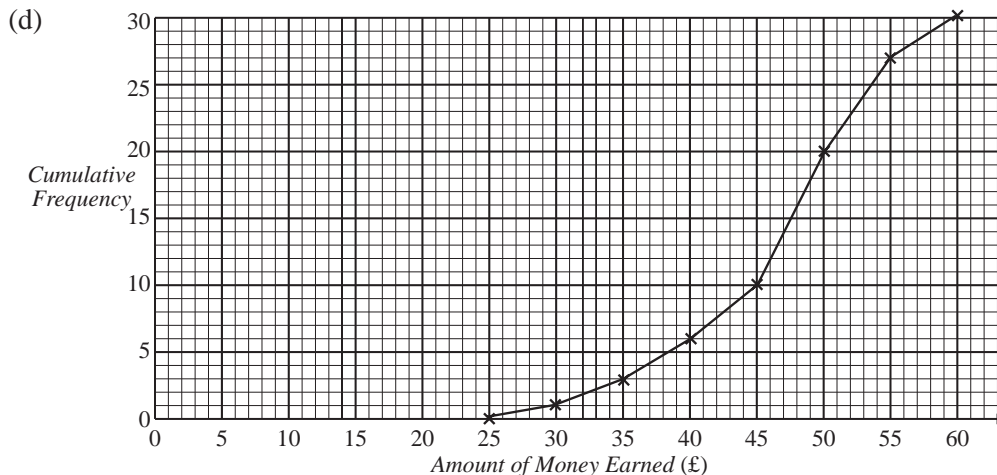

16.3

Answers

- (e) Statement A is *true*
 Statement B is *false* (the median corresponds to cumulative frequency 15, so lies in the interval $£45 \leq \text{amount earned} < £50$. The median = $£47.50$.)
 Statement C is *false* (only 10 out of the 30 students earned $£50$ or more.)

16.4 Box and Whisker Plots

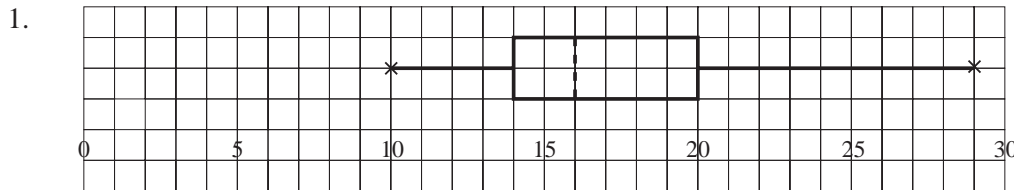

2. The data in order: 14, 16, 17, 18, 18, 19, 21, 21, 22, 25, 31, 33, 36, 39, 41
 Min = 14 LQ = 18 Median = 21 UQ = 33 Max = 41

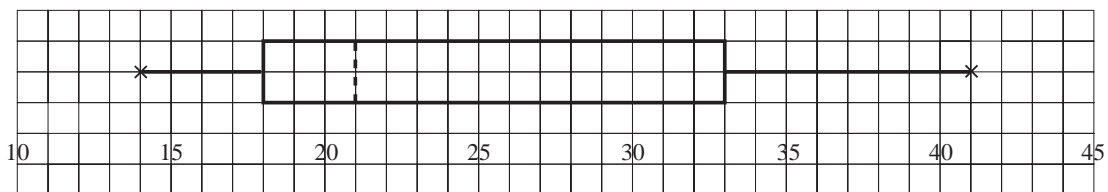

3. Min = 3 LQ = 12 Median = 17 UQ = 20 Max = 24

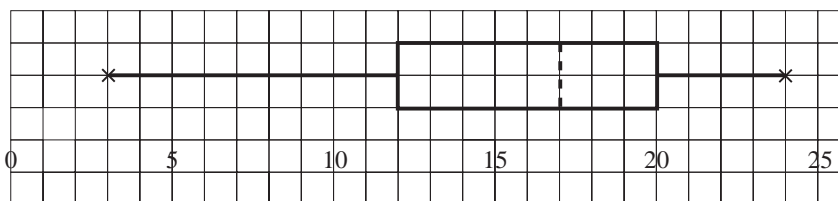

4. (a) Range = $58 - 12 = 46$ (b) Semi-interquartile range = $\frac{38 - 20}{2} = 9$

5. Median = 11 Semi-interquartile range = $\frac{18 - 7}{2} = 5.5$

6.

| | <i>Manufacturer A</i> | <i>Manufacturer B</i> |
|---------------------|-----------------------|-----------------------|
| Median | 4000 hours | 5000 hours |
| Lower quartile | 2500 hours | 3500 hours |
| Upper quartile | 4500 hours | 6000 hours |
| Range | 4000 hours | 6500 hours |
| Interquartile range | 2000 hours | 2500 hours |

From this table we can see that, on average, the light bulbs produced by manufacturer B have the longer life-span.

Although there is far more variation in the life-spans of type B, the lower quartile for type B is almost the same as the median for type A, which gives further support to manufacturer B producing the better light bulb.

16.4

Answers

7.

| | <i>Class 9P</i> | <i>Class 9Q</i> |
|---------------------|-----------------|-----------------|
| Median | 13 | 13 |
| Lower quartile | 10 | 11 |
| Upper quartile | 18 | 14 |
| Range | 13 | 11 |
| Interquartile range | 8 | 3 |

From this table we can see that both classes had the same average mark. There is far more variation in the scores for class 9P. Some students in 9Q performed better than their counterparts in 9P. In general, though, class 9P tended to score better marks than class 9Q.

8. (a) The builder might prefer to use the red bricks because that type has the higher median, i.e. they tend, on average, to be stronger than the yellow bricks.

(b) The builder might prefer to use the yellow bricks because that type has the smaller range, and the larger minimum, which means that he is less likely to get a weak brick.

Also, if the red bricks tend, on average, to be stronger than the yellow bricks, then they are likely to be more expensive, so he might prefer the yellow bricks if he wishes to save money at the expense of structural stability.

9.

| | <i>English</i> | <i>Mathematics</i> |
|---------------------|----------------|--------------------|
| Median | 10 | 10 |
| Lower quartile | 8 | 7 |
| Upper quartile | 12 | 16 |
| Range | 8 | 15 |
| Interquartile range | 4 | 9 |

From this table we can see that the class had the same average mark in both subjects. There is far more variation in the scores for Mathematics. Few pupils in the class scored high marks in the English test. Nobody scored full marks in either test. In general, though, the class tended to score better marks on the Mathematics test.

10. (a) Film C : minimum age to view is 18.

(b) Film B : 50% of the audience was between 14 and 30.

(c) Film A : the median age of the audience was 38 years, and only 25% of the audience was under 34 years old.

Practice Book *UNIT 17 Quadratic Functions*

Answers

17.1 Quadratic Expressions

1. (a), (b), (c) graphs

(d) $y = x^2 \rightarrow y = x^2 + 3$

translation $\begin{pmatrix} 0 \\ 3 \end{pmatrix}$

$y = x^2 \rightarrow y = x^2 - 2$

translation $\begin{pmatrix} 0 \\ -2 \end{pmatrix}$

2.

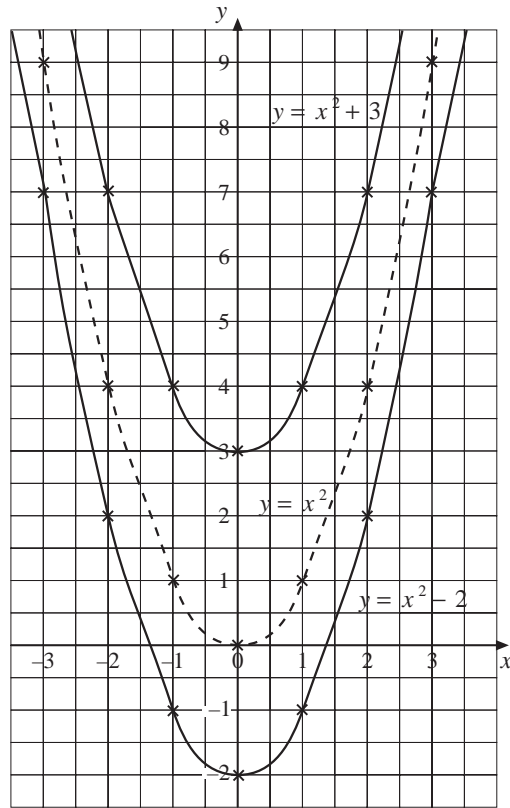
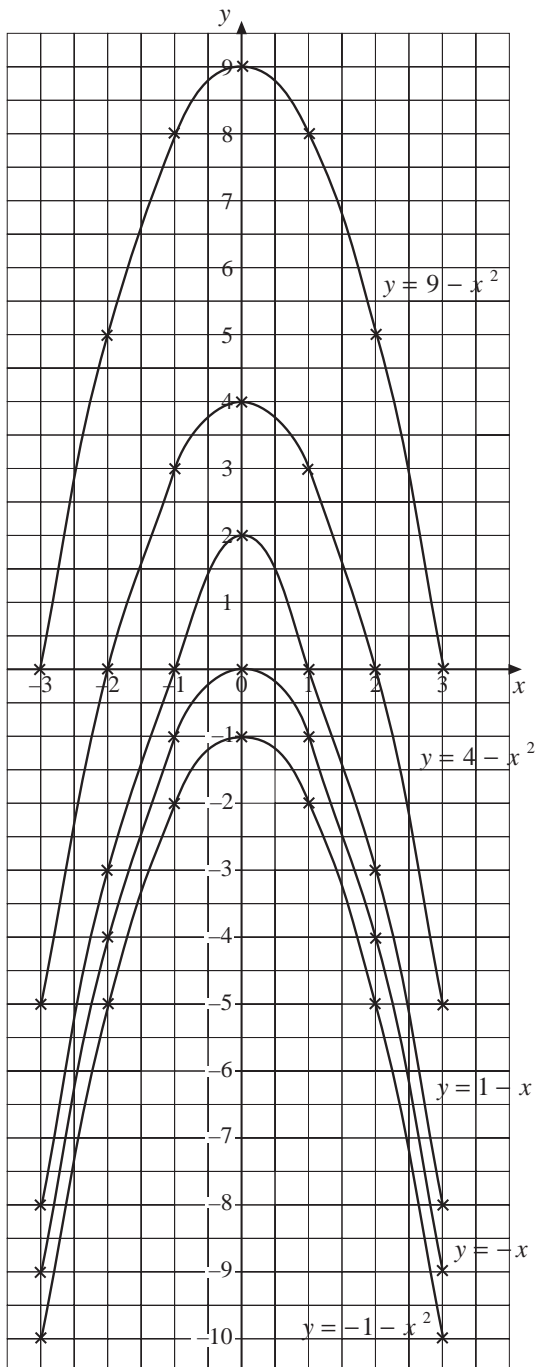

17.1

Answers

3.

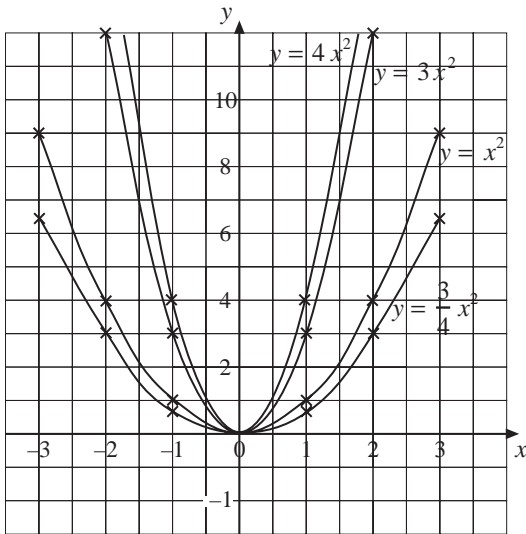

4.

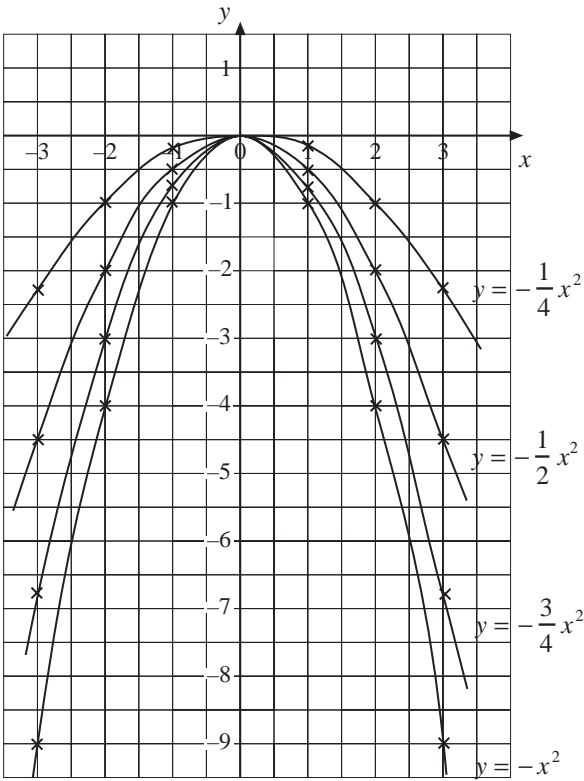

5.

(b) $(-2, 8), (2, 8)$

(a)

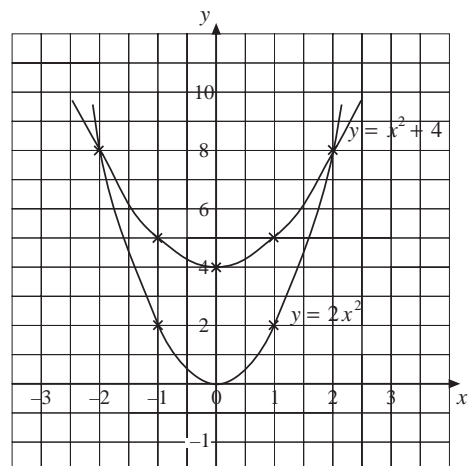

17.1

Answers

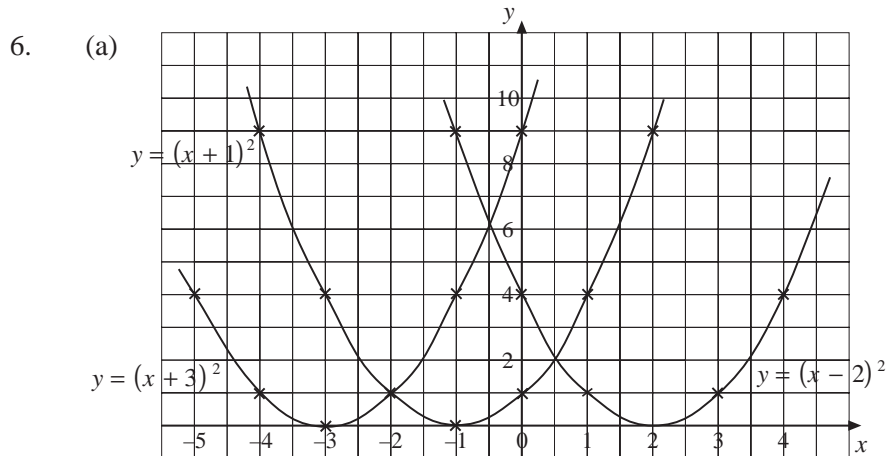

(b) $y = x^2 \rightarrow y = (x + 1)^2$ translation $\begin{pmatrix} -1 \\ 0 \end{pmatrix}$

$y = x^2 \rightarrow y = (x + 3)^2$ translation $\begin{pmatrix} -3 \\ 0 \end{pmatrix}$

$y = x^2 \rightarrow y = (x - 2)^2$ translation $\begin{pmatrix} 2 \\ 0 \end{pmatrix}$

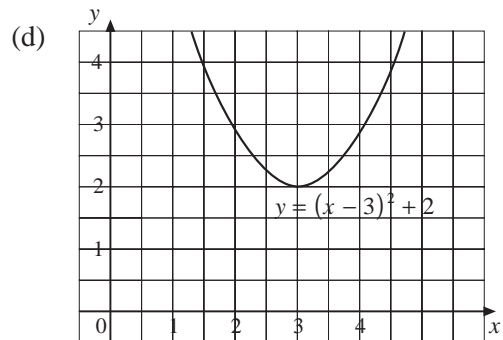
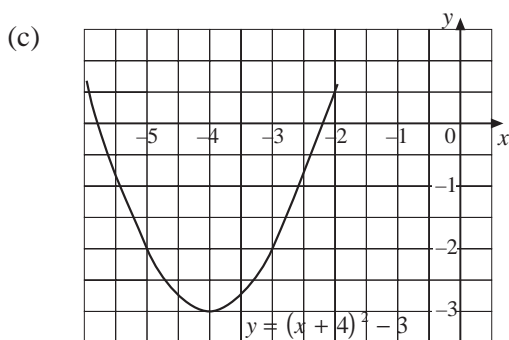
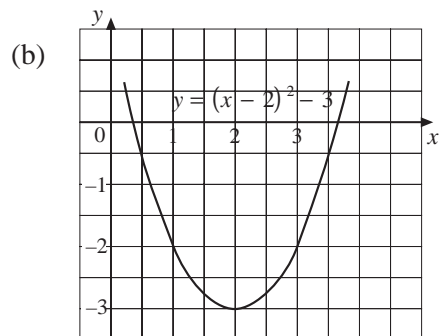
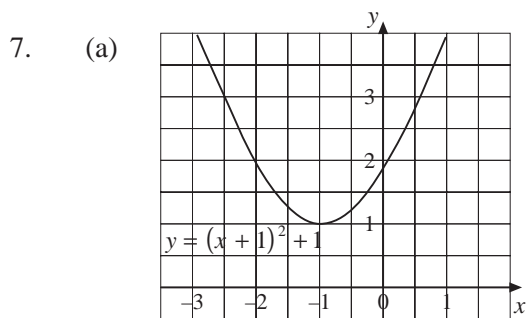
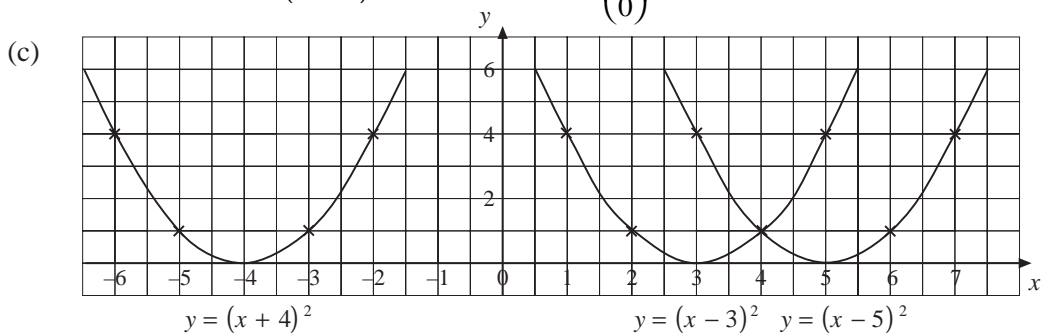

17.1

Answers

8. (a), (b)

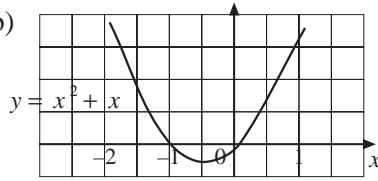

Lowest point $\left(-\frac{1}{2}, -\frac{1}{4}\right)$

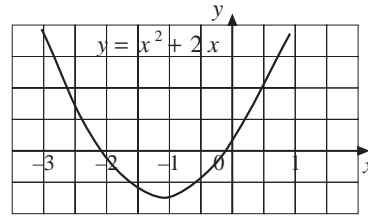

Lowest point $(-1, -1)$

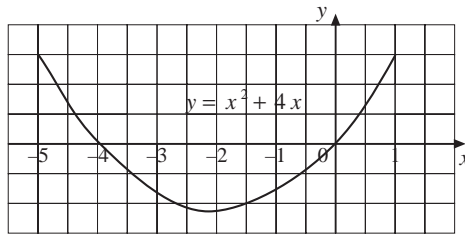

Lowest point $(-2, -4)$

Lowest point of $y = x^2 + bx$ is

$$\left(-\frac{b}{2}, -\frac{b^2}{4}\right).$$

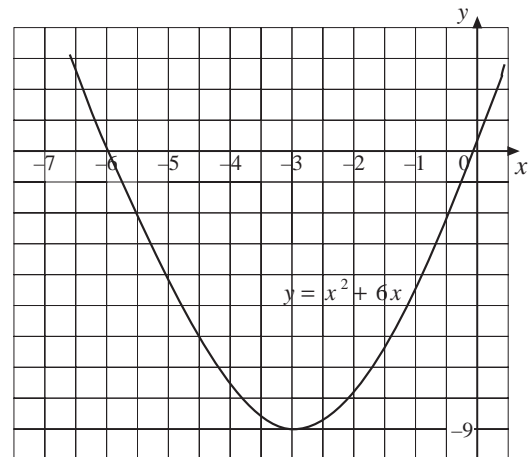

Lowest point $(-3, -9)$

(c)

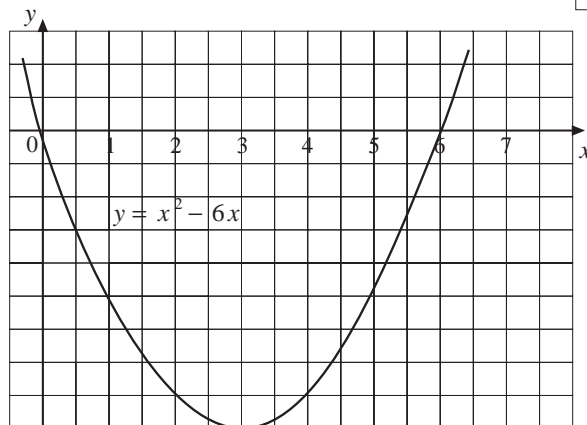
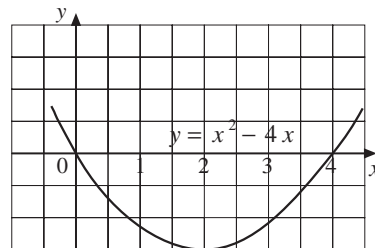
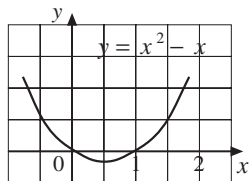

(d) $\left(\frac{b}{2}, -\frac{b^2}{4}\right)$

17.1

Answers

9. (a)

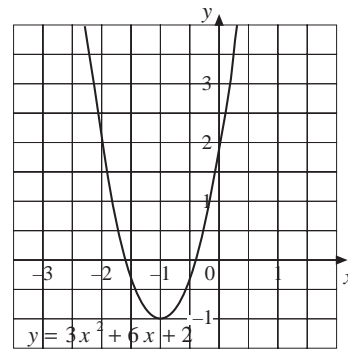
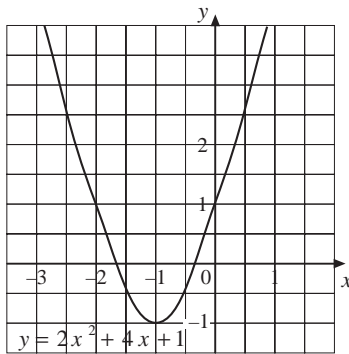

(b) (0, 1)

(0, 2)

(c) (0, c)

(d) (-1, -1)

(-1, -1)

(e) (-1, c - a)

10. (a)

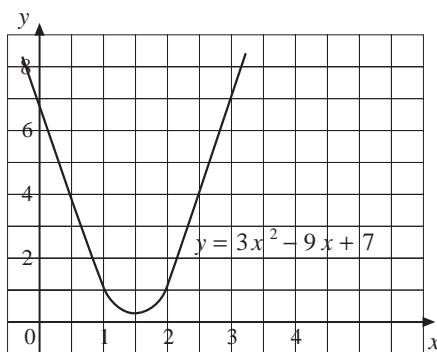
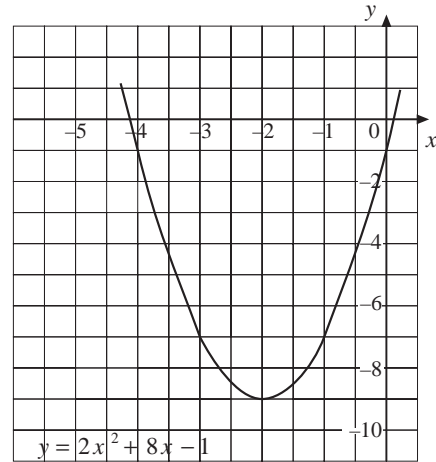
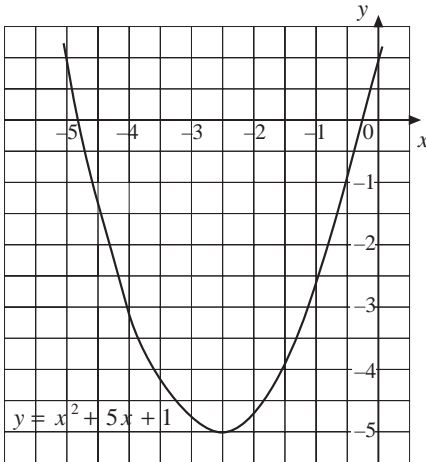

(b) $\left(-\frac{b}{2a}, \frac{4ac - b^2}{4a}\right)$

11. (a) c is the y-intercept (or value of y when x = 0) and graph shows y = 10 when x = 0

(b) $a = -\frac{1}{30}$; $b = 2$

17.2

Answers

17.2 Quadratic Equations: Factorisation

1. (a) $3(x + 7)$ (b) $5(x - 4)$ (c) $x(x - 1)$
 (d) $x(x + 6)$ (e) $x^2(x - 1)$ (f) $4x(2 + 5x)$
 (g) $2x(2 - 15x)$ (h) $x(5 + 16x)$ (i) $x^2(x^2 + 1)$
2. (a) $(x + 1)(x + 3)$ (b) $(x - 1)(x - 2)$ (c) $(x - 7)(x + 2)$
 (d) $(x - 20)(x - 1)$ (e) $(x + 5)(x + 7)$ (f) $(x - 5)^2$
 (g) $(x - 5)(x - 6)$ (h) $(x - 9)(x + 7)$ (i) $(x - 6)(x - 8)$
3. (a) 0, 4 (b) 0, -3 (c) 0, 7
 (d) $0, \frac{1}{4}$ (e) $0, \frac{7}{3}$ (f) $0, \frac{5}{2}$
4. (a) 2, 6 (b) -4, 2 (c) -3, 2
 (d) -4, 1 (e) 3, 5 (f) 2, 9
 (g) -3, 9 (h) -3, -7 (i) -1, 17
 (j) -5, -12
5. (a) 0, 8 (b) $0, \frac{4}{3}$ (c) 5, -10
 (d) 7, 10 (e) -8, 7 (f) -3, 17

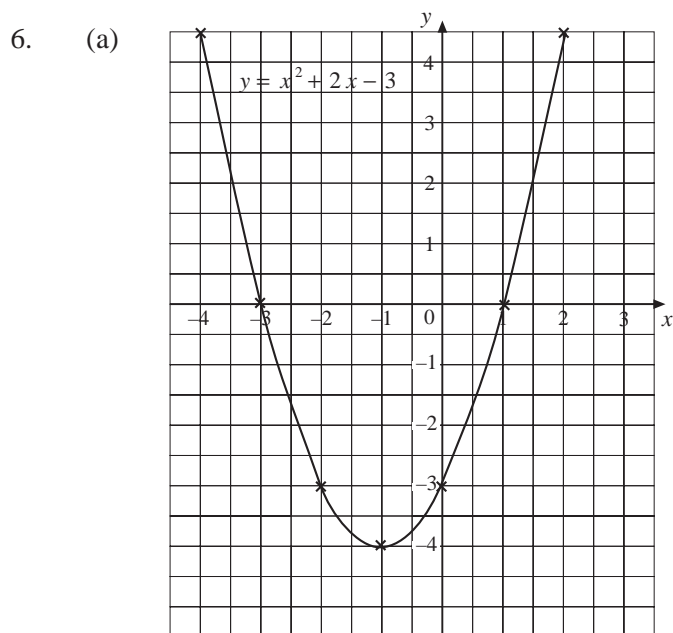

- (b) Graph crosses x -axis at two points, which are the x -values that give $y = 0$.

17.2

Answers

7. (a)

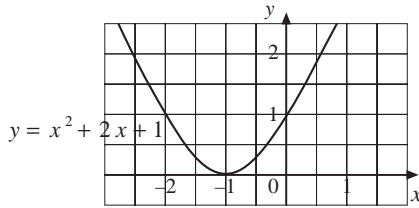

(b) One

(c) $(x + 1)^2 = 0$

so $(x + 1) = 0$

$x = -1$

8.

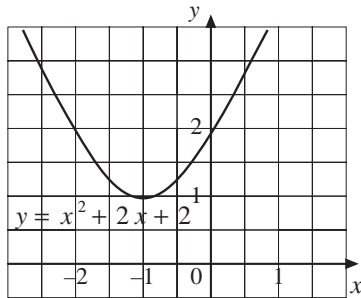
Graph does not cross x -axis, so there are no x -values for which $y = 0$.9. (c) $w = 2$ or -5 (d) cannot have width $= -5$

(e) 2 cm by 5 cm

10. 4 cm^3 11. $y = -5$ or $y = 1$

17.3 Quadratic Equations: Completing the Square

1. (a) $(x + 3)^2 - 9$

(b) $(x + 2)^2 - 4$

(c) $(x + 4)^2 - 16$

(d) $(x - 5)^2 - 25$

(e) $(x + 3.5)^2 - 12.25$

(f) $(x - 2.5)^2 - 6.25$

2. (a) $(x + 3)^2 - 8$

(b) $(x - 4)^2 - 13$

(c) $(x + 5)^2 - 37$

(d) $(x + 6)^2 - 28$

(e) $(x - 2)^2 - 3$

(f) $(x - 3)^2 - 12$

(g) $(x + 2.5)^2 - 3.25$

(h) $(x + 1.5)^2 - 6.25$

(i) $(x + 0.5)^2 - 2.25$

(j) $(x - 0.5)^2 + 2.75$

3. (a) 4, -2

(b) -3, -1

(c) -6, -2

(d) 1, 4

(e) -3, 5

(f) -7, 4

4. (a) -3.45, 1.45

(b) -4.24, 0.24

(c) -6.74, 0.74

(d) -0.10, 10.10

(e) -2.30, 1.30

(f) 0.38, 2.62

(g) -5.70, 0.70

(h) -4.19, 1.19

5. (a) $x(x + 4) = 20$

(b) 2.9 cm

6. (a) $(x - 4)^2 + 2 = 0$

(b) $(x - 4)^2$ cannot be negative

17.3

Answers

7. (a) $x^2 + 5x - 2 = 0$; $-5.37, 0.37$
(b) $x^2 - 2x + 3 = 0$; no solutions
(c) $x^2 + 2x - 3 = 0$; $-3, 1$
(d) $x^2 - 6x - 3 = 0$; $-0.46, 6.46$
8. (a) 20 (b) $t = 1$ or $t = 3$
9. 3
10. 53.0 cm
11. $-4.44948974, 0.44948974$

Practice Book *UNIT 18 Sampling*

Answers

18.1 Random Samples

1. This list of random digits generates the numbers

71 95 43 59 16 84 53 21 76 60 12 33 70 22
 63 71 35 33 23 65 24 65 11 30 85 73 96 55

The sample will consist of pupils

16 James 21 Daniella 12 Emma 22 Joseph 23 Anna

2. 98 85 90 98 84 45 27 50 94 67 93 02 63 29 12
26 60 49 50 99 93 75 10 05 90 93 06 06 47 76
 82 98 46 57 80 94 42 83 01 60 86 02 35 22 84
 70 88 81 40 63 96 70 08 30 08 17 57 97 13 21

The sample consists of pupils

27 Fatoumata 2 Lucy 29 Annie 12 Emma 26 Helen
 10 Rachel 5 Jayne 6 Nadima 1 Alan 22 Joseph

3. (a) 1 Jimmy Jump 2 Harold Hammer
 3 Tom Throw 4 Paul Discus
 5 Harry Hop 6 Paul Putt
 7 Sam Shot 8 Liam Long
 9 Jake Javelin 10 Victor Vault

(b) 26 60 49 50 99 93 75 10
05 90 93 06 06 47 76 82
 98 46 57 80 94 42 83 01
 60 86 02 35 22 84 70 88

This selects Victor Vault, Harry Hop and Paul Putt for drug testing.

4. This list of random digits in question 1 generates the numbers

71 95 43 59 16 84 53 21 76 60 12 33 70 22
 63 71 35 33 23 65 24 65 11 30 85 73 96 55

The houses that should be visited are those numbered

43 16 53 21 12 33 22 35 23 24

5. This list of random digits in question 1 generates the numbers

719 543 591 684 532 176 601 233 702 263
 713 533 236 524 651 130 857 396 55

The houses that should be visited are those numbered

532 176 233 263 533 236

18.1

Answers

6. (a) Number the entries on page 1 of the book from 0 to 249, those on page 2 number from 250-499, and so on until each entry has a number from 0 to 99 999. Then use random number tables to generate as many 5-digit numbers as are needed for the sample and take the corresponding entries from the telephone book.
- (b) This process does not produce a random sample for the area because not every person has a telephone, some people choose to go ex-directory and generally there is usually only one entry per household, so other people living at that address will not be included in the sample.

7. (a) Club members numbers are

| | | | | | |
|---------|----|----------|----|--------|----|
| Dee | 1 | Max | 2 | Ollie | 3 |
| Denise | 4 | Nazir | 5 | James | 6 |
| Tom | 7 | Jane | 8 | Hannah | 9 |
| Holly | 10 | Ferdi | 11 | Gemma | 12 |
| Richard | 13 | Kim | 14 | Nadia | 15 |
| Jai | 16 | Grant | 17 | Hugh | 18 |
| Victor | 19 | Juliette | 20 | Ben | 21 |
| Peter | 22 | Nigel | 23 | Ali | 24 |

- (b) The list of random digits in question 1 generates the numbers

71 95 43 59 16 84 53 21 76 60 12 33 70 22
 63 71 35 33 23 65 24 65 11 30 85 73 96 55

The following club members, with their ages, are selected for the first sample

Jai (13) Ben (13) Gemma (13) Peter (14) Nigel (14)

The mean age is 13.4 years

- (c) The list of random digits in question 1 in reverse order generates the numbers

55 69 37 58 03 11 56 42 56 32 33 53 17 36
22 07 33 21 06 67 12 35 48 61 95 34 59 17

The following club members, with their ages, are selected for the second sample

Ollie (18) Ferdi (11) Grant (12) Peter (14) Tom (16)

The mean age is 14.2 years

- (d) As can be seen, the two samples have different people, although there is some overlap because the list of random digits is fairly short.

The sample means are not the same, although they are reasonably close. We would not normally expect the means of two random samples (from the same population) to be the same.

8. (a) In a census, every member of the population is used so there can be no bias resulting from the sampling technique.
- (b) Using a census can be expensive (in terms of both cost and manpower); time consuming; difficult to achieve because of inaccessibility (e.g. a census of all the dolphins in the world); impossible (where it involves testing to destruction, e.g. matches).

18.1

Answers

9. Mr May should use a census. His class is small enough for the data to be found quickly and easily for every pupil in the class. Using a smaller sample may produce a biased value that would not reflect the class as a whole.
10. The headteacher should use a sample because the population (1800) is very large. It would take too long to obtain the information from every pupil, which would not be cost effective as an accurate value is unlikely to be needed. A reasonable sample of, say, 100 pupils, chosen randomly from across the whole school, should produce a realistic estimate for the true mean travel time.

18.2 Sampling Techniques

1. There are three possible samples, one being
Tom Nadima Mohammed Emma Miles Lisa Daniella Sophie Fatoumata Karen
2. Number the trees, row by row, from 1 to 400. Select trees numbered
16 32 48 64 80 96 112 128 144 160 176 192
208 224 256 272 288 304 320 336 352 368 384 400
3. Select houses numbered
17 34 51 68 85 102 119 136 153 170
187 204 221 238 255 272 289 306 323 340
4. 3 boys and 5 girls
5. Quota samples are not random.
The different samples (from which the quotas are selected) are usually of different sizes, so not every member of the population has an equal chance of being selected. Even if the categories were all equal in size, we would still not get a random sample because the person conducting the survey decides who to choose (usually based on simple convenience).
6. A systematic sample is not random because the items in the sample are determined immediately the starting point has been decided.
7. (a) Management 2 Technical 4 Administrative 4
(b) Management 1 Technical 2 Administrative 2
(c) Management 5 Technical 10 Administrative 10
8. See numbering of club members in answer to question 7 of Exercise 18.1.
- | | | |
|-------------|--------------|-------------|
| (a) 3 Ollie | (b) 4 Denise | (c) 6 James |
| 6 James | 8 Jane | 12 Gemma |
| 9 Hannah | 12 Gemma | 18 Hugh |
| 12 Gemma | 16 Jai | 24 Ali |
| 15 Nadia | 20 Juliette | |
| 18 Hugh | 24 Ali | |
| 21 Ben | | |
| 24 Ali | | |

18.2

Answers

9. (a) Select homes numbered
- | | | | | | | | | |
|----|----|----|----|----|----|----|----|----|
| 5 | 10 | 15 | 20 | 25 | 30 | 35 | 40 | 45 |
| 50 | 55 | 60 | 65 | 70 | 75 | 80 | 85 | 90 |
- (b) 4 bungalows
- (c) Both methods produce a sample with 4 bungalows.
10. Pupils' results will vary.

18.3 Stratified Random Samples

1. The sample will consist of 4 boys and 6 girls. The particular pupils will depend on the random numbers pupils obtain from random number tables or generate on their calculators or computers.
2. Delivery Drivers 3 Cooks 9
Cleaning Staff 1 Sales Staff 2
3. (a) They might want to use a stratified random sample if they don't have equal numbers of VW and Audi owners.
- (b) They need to generate a random sample of $\frac{40}{2000} \times 650 = 13$ Audi owners and $\frac{40}{2000} \times 1350 = 27$ VW owners.
They should number the Audi owners 1 to 650 and then use random numbers tables with 3-digit numbers to select 13 of them, using the first 13 different numbers selected in the range $1 \leq n \leq 650$.
They should number the VW owners 1 to 1350 and then use random number tables with 4-digit numbers to select 27 of them, using the first 27 different numbers selected in the range $1 \leq n \leq 1350$.
4. He should include $\frac{50}{300} \times 120 = 20$ Jersey cows and $\frac{50}{300} \times 180 = 30$ Friesians.
5. (a) There are 16 females and 24 males altogether so the sample should contain 4 females and 6 males.
- (b) The particular coins selected will depend on the random numbers pupils obtain from random number tables or generate on their calculators or computers.
6. Bus $\frac{50}{1200} \times 720 = 30$ Walk $\frac{50}{1200} \times 310 = 12\frac{11}{12}$
Cycle $\frac{50}{1200} \times 90 = 3\frac{3}{4}$ Car $\frac{50}{1200} \times 80 = 3\frac{1}{3}$

Rounding these to the nearest whole number, the sample would consist of

18.3

Answers

 30 pupils who travel by bus

13 pupils who walk

4 pupils who cycle

3 pupils who come by car

7. (a) A stratified random sample will reflect the different types of housing stock in the city. The views of the occupiers should therefore be more representative of opinion as a whole regarding the quality of homes within the city.

(b) Privately owned homes $\frac{200}{1500} \times 720 = 96$

Homes rented from the council $\frac{200}{1500} \times 592 = 78\frac{14}{15}$

Homes rented from private landlords $\frac{200}{1500} \times 188 = 25\frac{1}{15}$

Rounding these to the nearest whole number, the sample should consist of

96 privately owned homes

79 homes rented from the council

25 homes rented from private landlords

8. The results here will be specific to the class and the area in which the school is situated.

Answers

1 Indices

1.1 Multiplication and Division

- (a) 20 (b) 21 (c) 36 (d) 42 (e) 45 (f) 18
(g) 28 (h) 49 (i) 40 (j) 8 (k) 9 (l) 4
(m) 7 (n) 7 (o) 9 (p) 0 (q) 0 (r) 0
- (a) 3 (b) 7 (c) 4 (d) 8 (e) 3 (f) 4 (g) 9
(h) 7 (i) 3 (j) 7 (k) 4 (l) 5 (m) 2 (n) 4
(o) 7 (p) 0 (q) 0 (r) 0
- 24
- 27
- (a) 16 (b) 28 (c) 32
- (a) 6 (b) 3 (c) 4
- 8
- (a) 35 (b) 14 (c) 42
- (a) Daniel 70p, Joel 56p (b) Daniel has 14p more than Joel
- (a) 80 (b) 64 (c) 40
- £6
- (a) 9 (b) 7, with 1 left over
- Team A: 7, Team B: 21, Team C: 14, Team D: 14
- (a) 7 (b) 5

1.2 Squares, Cubes, Square Roots and Cube Roots

- (a) 25 (b) 36 (c) 1 (d) 49 (e) 6 (f) 1 (g) 7
(h) 5
- (a) 27 (b) 64 (c) 216 (d) 1000 (e) 3 (f) 10
(g) 6 (h) 4
- (a) 100 (b) 4 (c) 16 (d) 49 (e) 64 (f) 81
(g) 1 (h) 343 (i) 512 (j) 0 (k) 0 (l) 8
- (a) 10 (b) 2 (c) 9 (d) 8 (e) 4 (f) 3
- (a) 144 (b) 121 (c) 3375 (d) 2197 (e) 169 (f) 225
(g) 400 (h) 1331 (i) 11 (j) 20 (k) 13 (l) 15
(m) 15 (n) 13 (o) 12 (p) 11
- (a) 52 (b) 5 (c) 116 (d) 25 (e) 16 (f) 72
(g) 1001 (h) 100

1.3 Index Notation

1. (a) 4^5 (b) 3^3 (c) 6^7 (d) 7^4 (e) 18^3 (f) 19^2
 (g) 4^6 (h) 7^5 (i) 10^6 (j) 100^5
2. (a) 81 (b) 625 (c) 2401 (d) 10 000 (e) 1 (f) 729
 (g) 128 (h) 2 (i) 4096 (j) 4 (k) 1 (l) 25
3. (a) 2^{11} (b) 3^9 (c) 3^{13} (d) 4^5 (e) 5^4 (f) 5^5
 (g) 4^2 (h) 5^3 (i) 3^2 (j) 7^4 (k) 17^2 (l) 9^4
 (m) 4^5 (n) 4^{16} (o) 3^6 (p) $3^0 = 1$ (q) $3^1 = 3$
 (r) 3^5 (s) 3^7 (t) 4^7 (u) 5^0
4. (a) 2^2 (b) 2^3 (c) 2^4 (d) 2^6 (e) 3^3 (f) 5^2
 (g) 4^3 (h) 3^4 (i) 5^3
5. (a) 3^{13} (b) 2^8 (c) 4^{11} (d) 3^{10} (e) 2^9 (f) 2^{10}
 (g) 3^5 (h) 3^7 (i) 3^5 (j) 8^{10} (k) 7^3 (l) 9^2
 (m) 2^4 or 4^2 (n) 2^3 (o) 2^3
6. (a) 2^3 (b) 10^3 (c) 2^4 (d) 3^3 (e) 3^4 (f) 10^4
 (g) 5^4 (h) 4^3 (i) 6^4 (j) 2^0 (k) 6^2 (l) 5^0
7. (a) 2^6 (b) 3^4 (c) 6^6 (d) 5^6 (e) 2^8 (f) 4^6
 (g) 3^8 (h) 5^8 (i) 3^6
8. (a) 2^8 (b) 2^4 (c) 3^{10} (d) 5^3 (e) $(10^5)^3$ (f) $(7^5)^4$
9. (a) 3^6 (b) 2^{14} (c) 5^{12} (d) 7^3 (e) 7^4 (f) 2^7
 (g) $3^0 = 1$ (h) $4^1 = 4$ (i) $2^1 = 2$
10. (a) a^5 (b) a^{10} (c) x^9 (d) x^2 (e) y^3 (f) p^3
 (g) q^3 (h) x^8 (i) b^3 (j) b^6 (k) c^3 (l) x^5
 (m) y^2 (n) $x^0 = 1$ (o) x^8 (p) p^4 (q) x^3 (r) y^4
 (s) $x^0 = 1$ (t) $x^1 = x$ (u) x^{12} (v) x^8 (w) x^{15}
 (x) x^{54}
11. (a) $p = 3$ (b) $q = 0$
12. $2x^4$

1.4 Factors

- (a) 1, 2, 7, 14 (b) 1, 3, 9, 27 (c) 1, 2, 3, 6 (d) 1, 3, 5, 15
 (e) 1, 2, 3, 6, 9, 18 (f) 1, 5, 25 (g) 1, 2, 4, 5, 8, 10, 20, 40
 (h) 1, 2, 4, 5, 10, 20, 25, 50, 100 (i) 1, 3, 5, 9, 15, 45
 (j) 1, 2, 5, 10, 25, 50 (k) 1, 2, 3, 4, 6, 9, 12, 18, 36 (l) 1, 2, 4, 7, 14, 28
- (a) 1×10 , 2×5 , 5×2 , 10×1 (b) 1×8 , 2×4 , 4×2 , 8×1
 (c) 1×7 , 7×1 (d) 1×9 , 3×3 , 9×1
 (e) 1×16 , 2×8 , 4×4 , 8×2 , 16×1 (f) 1×22 , 2×11 , 11×2 , 22×1
 (g) 1×11 , 11×1
 (h) 1×24 , 2×12 , 3×8 , 4×6 , 6×4 , 8×3 , 12×2 , 24×1
- (a) 4 (b) 3 (c) 3 (d) 4 (e) 5 (f) 4 (g) 11
 (h) 1
- (a) 6, 10, 20, 8, 2, 24, 4 (b) 10, 20, 15, 55
- (a) (i) 20, 22, 24, 26 (ii) 21, 24, 27 (iii) 20, 25
 (b) prime numbers
- (a) (i) 16 (ii) 18 (b) (i) 25 (ii) 27

1.5 Prime Factors

- 2, 3, 5, 7, 13, 19, 23
- 53, 59
- (a) 2×5 (b) $2 \times 3 \times 7$ (c) $2^2 \times 17$ (d) $2^3 \times 3 \times 7$
 (e) 2×5^3 (f) $2 \times 3^3 \times 5$ (g) $3 \times 11 \times 13$ (h) $3 \times 5^2 \times 11$
 (i) $7 \times 11 \times 13$
- (a) $32 = 2^5$ and $56 = 2^3 \times 7$ (b) $2^3 (= 8)$
- (a) $2 \times 3 = 6$ (b) $2 \times 3 = 6$ (c) $3 \times 5 = 15$ (d) 2
 (e) $2 \times 5 = 10$ (f) $5 \times 7 = 35$ (g) $2^3 \times 3 = 24$
 (h) $2 \times 3 \times 13 = 78$ (i) $3 \times 7^2 = 147$
- (a) $45 = 3^2 \times 5$, $99 = 3^2 \times 11$, $135 = 3^3 \times 5$
 (b) (i) $3^2 = 9$ (ii) $3^2 = 9$ (iii) $3^2 \times 5 = 45$ (c) $3^2 = 9$
- (a) 5 (b) $3^2 \times 5 = 45$ (c) $2^3 = 8$ (d) $2 \times 5 = 10$
 (e) $2^3 \times 3 = 24$ (f) $2 \times 3 \times 5 = 30$ (g) $2^2 \times 3^3 = 108$
 (h) $2^2 \times 11 = 44$ (i) $2^2 \times 3^2 \times 7 = 252$

1.6 Further Index Notation

1. (a) $\frac{1}{16}$ (b) $\frac{1}{8}$ (c) $\frac{1}{6}$ (d) $\frac{1}{7}$ (e) 3 (f) 8 (g) 2
 (h) 3 (i) 1 (j) $\frac{1}{25}$ (k) 8 (l) 32 (m) 2187
 (n) 125 (o) $\frac{1}{2}$
2. (a) -4 (b) -1 (c) -3 (d) $\frac{1}{2}$ (e) $-\frac{1}{2}$ (f) 2
 (g) 3 (h) -1 (i) $\frac{1}{3}$ (j) -1 (k) -2 (l) -2
 (m) -3 (n) $\frac{1}{2}$ (o) -2 (p) $\frac{1}{3}$ (q) $\frac{2}{3}$ (r) $\frac{2}{5}$
3. (a) 0.125 (b) 0.05 (c) 2 (d) 4 (e) $\frac{1}{225} = 0.004444\dots$
 (f) 0.000125 (g) 729 (h) 27 (i) $\frac{1}{2}$ (j) 1728
 (k) 62748517 (l) 1331
4. (a) $\frac{1}{a}$ (b) a^{10} (c) a^4 (d) $\frac{1}{a^6}$ (e) $\frac{1}{a^2}$ (f) $\frac{1}{a^6}$
 (g) a^8 (h) $a^{\frac{5}{2}}$ (i) $\frac{1}{a^{\frac{3}{2}}}$ (j) a^2 (k) $\frac{1}{a^3}$ (l) a^3
 (m) $\frac{a^2}{b^2}$ (n) $\frac{a^6}{b^{12}}$ (o) $a^{12}b^2$ (p) $\frac{b^4}{a^4}$ (q) $\frac{a^8}{b^{12}}$
 (r) $\frac{m^2}{n^6}$ (s) $\frac{a^3}{b^5}$ (t) $\frac{m^2}{a}$ (u) $\frac{c^3}{a^4b}$ (v) $\frac{x}{m^2}$
 (w) $\frac{z^{12}}{x^8y^4}$ (x) $\frac{b^{\frac{16}{3}}}{a^2}$
5. (a) $\frac{1}{9}$ (b) a^4 (c) $y = \frac{5}{2}$

1.7 Standard Form

1. (a) 4.7×10^4 (b) 5.21×10^4 (c) 3.2×10^7 (d) 3.241×10^5
 (e) 4.2×10^2 (f) 8.1×10^4 (g) 5×10^3 (h) 4.7×10^{10}
 (i) 3.2×10^9 (j) 6.2×10^{-4} (k) 5.71×10^{-2} (l) 2.0×10^{-7}
 (m) 1.24×10^{-1} (n) 3.71×10^{-2} (o) 2.1×10^{-4} (p) 7×10^{-5}
 (q) 4.71×10^{-1} (r) 3×10^{-4}
2. (a) 1×10^6 (b) 1.5×10^4 (c) 6.4×10^6 (d) 3.04×10^7
 (e) 4×10^6 (f) 4×10^5
3. (a) 600 000 (b) 431 (c) 58 600 000 (d) 0.00083 (e) 4172
 (f) 0.0000642 (g) 47 (h) 0.32 (i) 0.000847
 (j) 334 000 000 (k) 0.0003471 (l) 842.1 (m) 16.75
 (n) 0.0000084 (o) 0.000712
4. (a) Yes (b) No: 4.32×10^3 (c) No: 1.56×10^{-7}
 (d) No: 4×10^2 (e) Yes (f) No: 7×10^{-5} (g) Yes
 (h) No: 5.471×10^4 (i) Yes
5. (a) 6×10^4 (b) 1.6×10^7 (c) 1.25×10^5 (d) 4×10^{-3}
 (e) 2×10^{-3} (f) 1.6×10^{-3} (g) 2.8×10^{-3} (h) 8.8×10^3
 (i) 9×10^{-4} (j) 9×10^2 (k) 4×10^{-4} (l) 1×10^4
6. (a) 5×10^4 (b) 6.2×10^5 (c) 1.456×10^6
7. (a) $365 \times 24 = 8.76 \times 10^3$ (b) $7 \times 24 \times 60 = 1.008 \times 10^4$
 (c) $24 \times 60^2 = 8.64 \times 10^4$
8. (a) 6370 km (b) $6370000 = 6.37 \times 10^6$
 (c) $2 \times \pi \times 6.37 \times 10^6 = 4.0024... \times 10^7$
9. 5 900 000 000 000 000 000 000 000 000 10. 3×10^{-2} mm
11. 4.82×10^8 kg
12. (a) 153 000 000 km and 147 000 000 km
 (b) 1.53×10^{11} m and 1.47×10^{11} m
13. (a) 4.444355556×10^9 (b) 3.68785269×10^8 (c) 8×10^9
 (d) 1.536×10^{11} (e) 1.6544×10^{10} (f) 2.24×10^9

1.8 Calculations with Standard Form

1. (a) 6×10^{12} (b) 8×10^8 (c) 9×10^{16} (d) 2×10^{12}
 (e) 2.4×10^{15} (f) 1.2×10^7 (g) 2.88×10^{11} (h) 2.2×10^2
 (i) 5.832×10^7 (j) 6.76×10^{-4} (k) 1.302×10^{-8}
 (l) 4.5×10^{-13}
2. (a) 4×10^4 (b) 3×10^3 (c) 2×10^2 (d) 8×10^2
 (e) 1.2×10^6 (f) 1.2×10^9 (g) 2.7×10^{-1} (h) 5×10^7
 (i) 4.1×10^{19} (j) 1.1×10^8 (k) 3×10^9 (l) 1.1×10^{-10}
3. (a) 1.764×10^{13} (b) 1.369×10^{-3} (c) 1.728×10^{-15}
 (d) $2.846... \times 10^4$ (e) 7.44×10^{22} (f) 1.558×10^{-7}
 (g) $9.5833... \times 10^{-2}$ (h) 1.46875×10^3 (i) 5.0625×10^{-10}
 (j) $2.449... \times 10^2$ (k) 5.12×10^{11} (l) 6.753×10^{12}
4. (a) 8.64×10^5 (b) 6.048×10^5 (c) 3.1536×10^7
5. (a) 2.73×10^{-12} kg (b) 3.64×10^2 kg (c) 6.37×10^{-22} kg
6. 1.26×10^{12} mm²
7. (a) (i) 3.32×10^3 m (ii) 9.96×10^5 m (iii) 1.328×10^1 m
 (b) (i) $3.012... \times 10^{-2}$ s (ii) 6.024... s (iii) $6.024... \times 10^{-5}$ s
8. (a) 3×10^{10} m (b) 5×10^2 s (8 min 20 s)
9. (a) 3.84×10^8 m (b) 9.6×10^5 s (266 hours 40 min)
10. (a) 1×10^6 cm³ (b) 1.3 kg (c) $2.30769... \times 10^3$ cm³
 (d) 9×10^{-2} kg, $3.333... \times 10^4$ cm³
11. $4.5 \times 10^9 \times (1.03)^{10} = 6.0476... \times 10^9$
12. (a) 52 000 000 (b) 1.2×10^{-1} cm 13. 8.54×10^8
14. 1.845×10^{11} tonnes (2 $\times 10^{11}$ to 1 s.f.)
15. (a) 4.29981696 (b) 3×10^{-2}
16. (a) 1.496×10^8 (b) $2.5752... \times 10^6$
17. (a) 5×10^{101} (b) 5×10^{-8}

2 Formulae

2.1 Using Formulae

- (a) $A = 8, P = 12$ (b) $A = 30, P = 26$ (c) $A = 22, P = 26$
 (d) $A = 20, P = 18$
- (a) 16 (b) 12 (c) 15 (d) 20
- (a) 30 (b) 400
- (a) 30 (b) 12 (c) 17
- (a) 60 (b) 105 (c) 144
- (a) 26 (b) 14 (c) 19 (d) 46 (e) 18 (f) 12
 (g) 4 (h) 2 (i) 26 (j) 50 (k) 30 (l) 40 (m) 6
 (n) 10
- £130 8. 17.4 cm

2.2 Construct and Use Simple Formulae

- (a) $P = 2a + b, P = 16$ (b) $P = 4a, P = 20$ (c) $P = 5a + b, P = 40$
 (d) $P = a + 2b + c, P = 27$ (e) $P = 6a, P = 60$
 (f) $P = 2a + 2b + 2c, P = 36$ (g) $P = 2a + 2b + c, P = 520$
 (h) $P = 3a + b, P = 21$
- (a) $A = ab, A = 60 \text{ cm}^2$ (b) $A = a^2, A = 9 \text{ cm}^2$
 (c) $A = a^2 + ab, A = 20 \text{ cm}^2$ (d) $A = ab + bc, A = 48 \text{ cm}^2$
 (e) $A = \frac{1}{2}ab, A = 10 \text{ cm}^2$ (f) $A = \frac{1}{2}ab + b^2, A = 45000 \text{ cm}^2$
- (a) $(x + 1)$ and $(x + 2)$ (b) $T = 3x + 3$
- (a) $M = \frac{x + y}{2}$ (b) $M = \frac{p + q + r + s + t}{5}$
- (a) $T = 3p + 2q$ (b) £190
- (a) $P = 2x + 2(x + 3) = 4x + 6$ (b) $A = x(x + 3)$
- (a) $x + 1$ (b) $x - 3$ (c) $S = 3x - 2$
- (a) $C = 3 + 2n$ (b) £19
- (a) $C = 1 + 2m$ (b) £7

2.2

10. (a) $2n$ (b) $2n + 6$
11. (a) $100 - 8x$ (b) $(20 - 2x)(30 - 2x)$
12. $C = 27n$
13. (a) $C = 45l$ (b) $C = xl$
14. (a) $S = P + Q$ (b) (i) $S = X + 3250$ (ii) $S = X + 650n$

2.3 Revision of Negative Numbers

1. (a) -2 (b) 4 (c) -3 (d) -8 (e) 24 (f) 54
(g) 8 (h) -8 (i) 27 (j) 8 (k) -13 (l) -35
(m) -24 (n) -11 (o) -5 (p) 3 (q) 11 (r) 3
(s) -8 (t) -6 (u) -1
2. (a) 1 (b) 16 (c) 25 3. -3°C 4. 24°C

2.4 Substitution into Formulae

1. (a) 50 (b) 68 (c) 14 (d) 23 (e) -4 (f) 59
2. (a) 10 (b) 40 (c) 11.25 (d) 4 (e) -10 (f) 7.04
3. (a) 19.6 (b) 18.4 (c) 18.08 (d) 18.8
4. (a) -280 (b) -40 (c) 80 (d) 800 ; 4
5. (a) 80 (b) 51 (c) ± 4 (d) ± 3 (e) -3 (f) ± 5
(g) 0 (h) $\frac{3}{4}$ (i) 1 (j) 10 (k) -2 (l) -10
(m) ± 10 (n) 0.18 (o) 0.38 (p) ± 5 (q) ± 8 (r) ± 15
6. (a) 3.8 (b) 0.225 (c) 2.6 (d) 7.5 (e) 9.7 (f) 2.4
(g) 0.5 (h) 7.12 (i) 3.7
7. -21.67 (2 d.p.)
8. -13
9. (a) $-\frac{13}{8}$ (b) $-\frac{5}{8}$

2.5 More Complex Formulae

- (a) $\frac{12}{7}$ (b) -30 (c) $-\frac{21}{4}$ (d) $-\frac{20}{3}$
- (a) ± 1.3 (b) ± 8 (c) ± 3.4
- (a) $-\frac{3}{2}$ (b) $\frac{12}{25}$ (c) -10 (d) $\frac{10}{4} \left(= \frac{5}{2} \right)$ (e) -4
(f) $-\frac{1}{3}$ (g) $-\frac{17}{7}$ (h) $\frac{7}{9}$ (i) 1
- (a) ± 5 (b) ± 12 (c) ± 7 (d) ± 11 (e) ± 2 (f) ± 13
- (a) $\frac{60}{11}$ (b) 588.24 (2 d.p.) (c) 572.67 (2 d.p.)
- 33.5
- (a) -32.3 (3 s.f.) (b) -30
- (a) i) 0.2kg ii) kg per cm^3 , kgcm^{-3} or $\frac{\text{kg}}{\text{cm}^3}$ (b) 2.29kg (2dp)

2.6 Changing the Subject

- (a) $x = \frac{y}{4}$ (b) $x = \frac{y-3}{2}$ (c) $x = \frac{y+8}{4}$ (d) $x = 4y - 2$
(e) $x = 5y + 2$ (f) $x = y - a$ (g) $x = ya + b$ (h) $x = \frac{y-c}{a}$
(i) $x = \frac{yc-b}{a}$ (j) $x = \frac{yb+c}{a}$ (k) $x = y - a - b$ (l) $x = yc + a - b$
(m) $x = \frac{y}{ab}$ (n) $x = \frac{y-c}{ab}$ (o) $x = \frac{3cy+b}{4a}$ (p) $x = \frac{pd+bc}{a}$
(q) $x = \frac{y}{b} - a$ (r) $x = \frac{4y}{a} - 3$ (s) $x = \frac{2q}{3} + 4$ (t) $x = \frac{4v}{5} - y$
(u) $x = 4(z - a) + 3$
- $I = \frac{V}{R}$; $R = \frac{V}{I}$
- $m = \frac{F}{a}$; $a = \frac{F}{m}$
- $r = \frac{C}{2\pi}$
- (a) $t = \frac{v-u}{a}$ (b) $a = \frac{v-u}{t}$

6. $z = 3m - x - y$

7. (a) $a = \frac{v^2 - u^2}{2s}$ (b) $a = \frac{s}{(t + \frac{1}{2}t^2)}$

8. $z = \frac{v}{xy}$

9. (a) $r = +\sqrt{\frac{V}{\pi h}}$ (only a positive value because r is radius) (b) 2.82

10. (a) $h = \frac{V}{x^2}$; $h = \frac{A - 2x^2}{4x}$ (b) 2 (c) 2.5

11. (a) $a = \frac{2A}{h} - b$ (b) $A = \frac{1}{2} \times 3a \times h = \frac{3ah}{2}$; $a = \frac{2A}{3h}$

2.7 Further Change of Subject

1. (a) $x = \frac{5-y}{3}$ (b) $x = \frac{8-y}{6}$ (c) $x = \frac{a-y}{2}$ (d) $x = \frac{6-5y}{2}$

(e) $x = \frac{8-2y}{7}$ (f) $x = \frac{3y+5}{7}$ (g) $x = a - b - 2p$ (h) $x = 10 - aq$

(i) $x = \frac{q - rb}{5}$

2. (a) $a = 4q^2$ (b) $a = bz^2$ (c) $a = \frac{c}{z^2}$ (d) $a = \frac{3y^2}{8}$

(e) $a = 32bv^2$ (f) $a = \frac{\pi r^2}{25}$ (g) $a = 4p^2 - b$

(h) $a = b - 12r^2$ (i) $a = \frac{18}{c^2} - b$

3. (a) $\frac{2}{2a-1}$ (b) $\frac{1}{b+2}$ (c) $\frac{1}{2-x}$ (d) $\frac{3x}{3-x}$ (e) $\frac{5p}{5+p}$

(f) $\frac{6x}{3-x}$ (g) $\frac{4rv}{v-2r}$ (h) $\frac{7q}{q-7}$ (i) $\frac{ap}{p-a}$

4. (a) $g = \frac{4\pi^2 l}{T^2}$ (b) 10.07 (2 d.p.)

5. (a) $v = \frac{uf}{u-f}$ (b) -24

6. (a) $h = \frac{v^2}{2g}$ (b) 1.8 (c) $g = \frac{v^2}{2h}$ (d) 0.8

7. (a) $R = \frac{u^2}{g}$ (b) 14.4

8. (a) $X = \frac{RYZ}{YZ - RZ - RY}$ (b) 24
9. (a) $r = \sqrt[3]{\frac{3V}{4\pi}}$ (b) 2.62 (2 d.p.)

2.8 Expansion of Brackets

1. (a) $3x + 3$ (b) $4a + 8$ (c) $3x - 18$ (d) $15 - 5b$
 (e) $16 - 2x$ (f) $3x + 12$ (g) $10x - 24$ (h) $12x - 30$
 (i) $6x + 21$
2. (a) $-2x - 12$ (b) $-3x - 6$ (c) $-6x + 18$ (d) $-7x + 14$
 (e) $-8x - 4$ (f) $-15 + 10x$ (g) $-6x + 16$ (h) $12 + 3x$
 (i) $-16 + 32x$
3. (a) $x^2 + x$ (b) $x - x^2$ (c) $x^2 - 6x$ (d) $-3x^2 + 2x$
 (e) $-4x^2 + 6x$ (f) $4a^2 + 5a$ (g) $6a^2 - 15a$ (h) $12y^2 - 63y$
 (i) $30y - 12y^2$
4. (a) $2x - 13$ (b) $x^2 - 2x$ (c) $5x + 23$ (d) $6x + 6$
 (e) $11x - 28$ (f) $n^2 + 10n - 8$ (g) $2a + 28$
 (h) $3x^2 - 10x + 24$ (i) $3x^2 - 5x$
5. (a) $x^3 + x^2$ (b) $2x^3 - 10x^2$ (c) $2x + 6$ (d) $8x - 4$
 (e) $6x^3 - 12x$ (f) $4x^3 + 2x^2 + 4x$ (g) $2ap + aq + bp$
 (h) $3ny + 4xy - 5nx$ (i) $2xp$
6. (a) $x^2 + 4x$ (b) $a^2 - a$ (c) $x^2 - 2x$
7. (a) $2(x + 1)$ (b) $2x + 2$ (c) Double then add 2
 (d) $x(x + 1) = x^2 + x$ Think of a number, multiply it by itself then add the original number.
8. (a) b (b) $c - a$ (c) $b(c - a)$ (d) $bc - ba$

2.9 Factorisation

- (a) 5 (b) 2 (c) 5 (d) $(3x + 2)$ (e) $(3 - n)$
 (f) $(2x - 7)$ (g) $(2a + 3)$ (h) $(11x - 3)$
- (a) $6(x + 4)$ (b) $5(x - 4)$ (c) $8(2 - x)$ (d) $4(2n + 3)$
 (e) $2(6x - 7)$ (f) $3(a - 8)$ (g) $11(x - 6)$ (h) $5(2 + 5x)$
 (i) $20(5x - 2)$ (j) $10(5 - 4x)$ (k) $6(x - 5)$ (l) $5(y - 9)$
 (m) $12(1 + 3x)$ (n) $16(x + 2)$ (o) $3(9x - 11)$
- (a) x (b) x (c) a (d) $(4x + 1)$ (e) $(x + 4)$
 (f) $(2x + 1)$ (g) $(a + b)$ (h) $(2x - a)$
- (a) $x(5x + 1)$ (b) $a(a + 3)$ (c) $n(5n + 2)$ (d) $3n(2n + 1)$
 (e) $5n(n - 2)$ (f) $3x(x + 2)$ (g) $15x(x - 2)$ (h) $7x(2x + 3)$
 (i) $8x(2x + 3)$ (j) $6x(5x - 3)$ (k) $5(1 + n^2)$ (l) $5(2n^2 - 3)$
 (m) $3n(n^2 + 3)$ (n) $9x(x - 3)$ (o) $5x^2(2x - 1)$
- (a) $ax(1 + x)$ (b) $x(b + cx)$ (c) $2q(p - 2r)$ (d) $5y(3x - y)$
 (e) $8p(2q + 3p)$ (f) $6x(x + 3y)$ (g) $3p(p - 3x)$
 (h) $8x(3p + 7x)$ (i) $2xy(8x - 9y)$
- (a) $2x(3x + 2)$ (b) $8x^2(2x + 1)$ (c) No (d) $3xy(x - 6y)$
- (a) $6x(6 + x)$ (b) $x = \frac{y-3}{5}$

2.10 Algebraic Manipulation

- (a) $-a - b$ (b) $\frac{b-d}{a-c}$ (c) $\frac{-1}{a-b}$ (d) $4a + 6$ (e) $\frac{c-b}{3}$
 (f) $\frac{a-c}{b-d}$ (g) $\frac{a-2}{3}$ (h) a (i) $\frac{p+q}{q-p}$ (j) $3a + 2b$
 (k) $\frac{-5-a}{3}$ (l) $\frac{ab}{4-a}$
- (a) $\frac{P}{1-P}$ (b) $\frac{b}{P-a}$ (c) $\frac{Qa+b}{Q-1}$ (d) $\frac{q^2y+y}{q^2-1}$
 (e) $\frac{-2-3a}{a-1}$ (f) $\frac{4c-b}{3}$ (g) $\frac{p^2}{1-p^2}$ (h) $\frac{-2}{w^2-1}$ or $\frac{2}{1-w^2}$
 (i) $\frac{w^2+2}{1-w^2}$ (j) $\pm \sqrt{\frac{2}{p-1}}$ (k) $\pm \sqrt{\frac{3p-2}{p-1}}$ (l) $\pm \sqrt{\frac{gy+y}{1-g}}$

2.11 Algebraic Fractions

1. (a) $\frac{9x}{20}$ (b) $\frac{11x}{28}$ (c) $\frac{8x}{15}$ (d) $\frac{41y}{21}$ (e) $\frac{23y}{20}$ (f) $\frac{13y}{7}$
 (g) $\frac{19x}{70}$ (h) $\frac{x}{6}$ (i) $\frac{9x}{8}$ (j) $\frac{27x}{24}$ (k) $\frac{5a+4b}{20}$
 (l) $\frac{8x+3y}{24}$ (m) $\frac{5a-3b}{15}$ (n) $\frac{10a+12b}{15}$ (o) $\frac{32a-27b}{36}$
2. (a) $\frac{4y+2x}{xy}$ (b) $\frac{6y-x}{xy}$ (c) $\frac{y+3x}{xy}$ (d) $\frac{5}{a}$ (e) $\frac{8b+3a}{2ab}$
 (f) $\frac{10b-3a}{6ab}$ (g) $\frac{25b+12a}{15ab}$ (h) $\frac{23}{15a}$ (i) $\frac{17}{28a}$
 (j) $\frac{21b-16a}{24ab}$ (k) $\frac{1}{12a}$ (l) $\frac{11}{8a}$
3. (a) $\frac{2x+1}{x(x+1)}$ (b) $\frac{3x+4}{x(x+2)}$ (c) $\frac{7x+3}{x(x+1)}$ (d) $\frac{4x+10}{x(x+2)}$
 (e) $\frac{4x+2}{x(x+2)}$ (f) $\frac{14x-12}{3x(x+3)}$ (g) $\frac{-6}{x(x+1)}$ (h) $\frac{6x-10}{x(x-5)}$
 (i) $\frac{27x+42}{5x(x+6)}$ (j) $\frac{17x-49}{2x(x-7)}$ (k) $\frac{23x-50}{3x(x-10)}$ (l) $\frac{7x-8}{3x(x-8)}$
4. (a) $\frac{2x+3}{(x+1)(x+2)}$ (b) $\frac{2x}{(x+1)(x+1)}$ (c) $\frac{7}{(x+2)}$
 (d) $\frac{6x-28}{(x-2)(x-6)}$ (e) $\frac{-x-2}{(x+3)(x+4)}$ (f) $\frac{x+35}{(x+7)(x-7)}$
 (g) $\frac{8x+28}{(x-4)(8+x)}$ (h) $\frac{-2x+30}{(x-4)(x+7)}$ (i) $\frac{8x+27}{(x+6)(x-1)}$
 (j) $\frac{5x-2}{(2x+6)(3x-8)}$ (k) $\frac{-6x}{(2x+5)(5-4x)}$ (l) $\frac{17x-7}{(2x-1)(3x-1)}$
 (m) $\frac{37x+13}{(2x+3)(5x-1)}$ (n) $\frac{18x+4}{(3x-7)(2x+3)}$ (o) $\frac{29x+9}{(5x-4)(2x+3)}$
5. (a) $\frac{3x^2}{(x+1)(x-2)}$ (b) $\frac{15x}{(x-7)(2x+1)}$ (c) $\frac{5x^2-3x}{(x-1)(3x-1)}$
 (d) $\frac{x^2+3x+12}{(x+3)(x-1)}$ (e) $\frac{8x^2+11x}{(x-3)(x+4)}$ (f) $\frac{5x}{(2-x)(4x-3)}$
 (g) $\frac{5x^2-13x}{(5-x)(x+1)}$ (h) $\frac{-4x^2-14x}{(4+x)(x+6)}$ (i) $\frac{x^2-4x-18}{(x+6)(x-1)}$

3 Angle Geometry

3.1 Measuring Angles

Note that measured angles are approximate answers

1. (a) 78° (b) 120° (c) 60° (d) 130° (e) 125° (f) 60°

3. (a) 315° (b) 195° (c) 240° (d) 325° (e) 264°
(f) 350°

5. (a) $a = 62^\circ, b = 118^\circ$ (b) $a = 58^\circ, b = 76^\circ, c = 46^\circ$
(c) $a = 104^\circ, b = 76^\circ$ (d) $a = 42^\circ, b = 74^\circ, c = 64^\circ$
The angles add up to 180°

6. (a) $50^\circ, 60^\circ, 70^\circ$ (b) $31^\circ, 59^\circ, 90^\circ$ (c) $15^\circ, 19^\circ, 147^\circ$
(d) $33^\circ, 40^\circ, 107^\circ$ The three angles add up to 180°

7. (a) $a = 150^\circ, b = 90^\circ, c = 120^\circ$ (b) $a = 152^\circ, b = 116^\circ, c = 63^\circ, d = 29^\circ$
(c) $a = 48^\circ, b = 154^\circ, c = 35^\circ, d = 123^\circ$ (d) $a = 45^\circ, b = 45^\circ, c = 270^\circ$
In each case the angles add up to 360°

8. (c) 7.7 cm and 6.4 cm, 90°

9. (b) 11.5 cm, $34^\circ, 66^\circ$

10. (a) $34^\circ, 34^\circ, 51^\circ, 241^\circ$ (b) $25^\circ, 29^\circ, 98^\circ, 208^\circ$
In both cases the angles add up to 360°

11. The interior angles will always add up to 540°

3.2 Line and Rotational Symmetry

1. (a) B - 2 lines, D - 2 lines, E - 1 line, F - 1 line, G - 4 lines, I - 1 line
(b) A - order 4, B - order 2, D - order 2, G - order 4, H - order 3

2. A - has symmetry, no lines, order 3 B - has symmetry, 1 line, no order
C - has symmetry, 1 line, no order D - has symmetry, 1 line, no order
E - has symmetry, 1 line, no order F - has symmetry, 4 lines, order 8
G - has symmetry, 1 line, no order H - has symmetry, no lines, order 4
I - no symmetry, no lines, no order

3. (a)

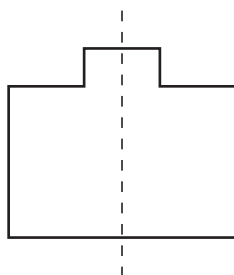

- (b)

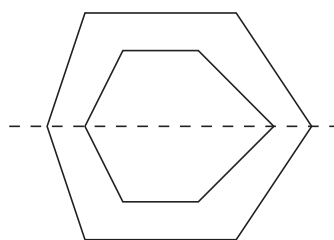

(c)

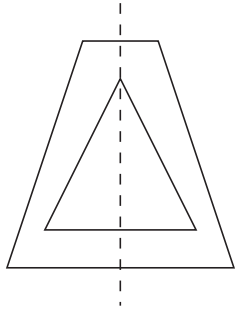

(d)

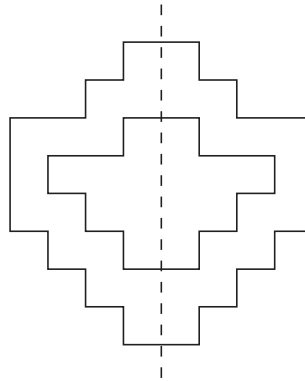

(e)

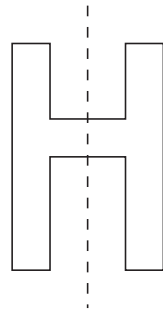

(f)

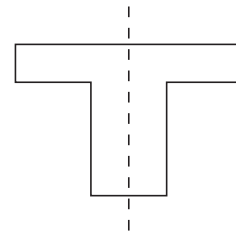

4. (a)

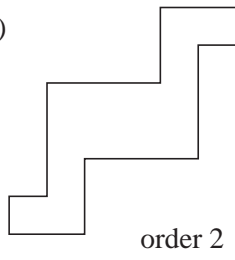

(b)



(c) Not possible

(d)

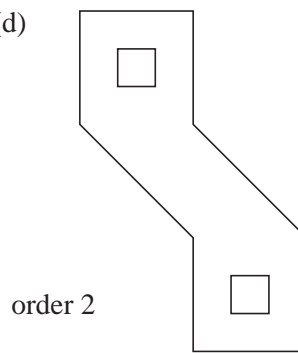

(e)

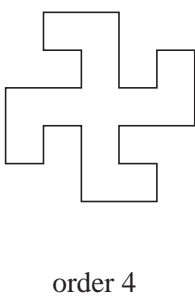

(f)

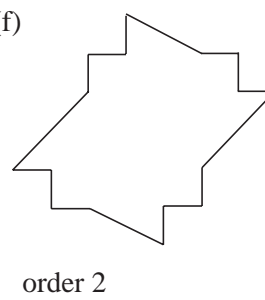

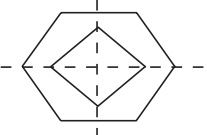
5. (a) 
Order 2

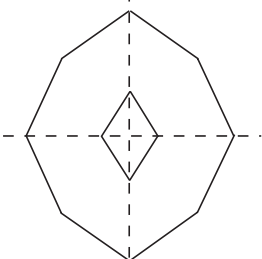
(b) 
Order 2

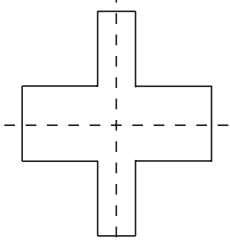
(c) 
Order 2

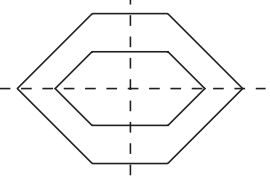
(d) 
Order 2

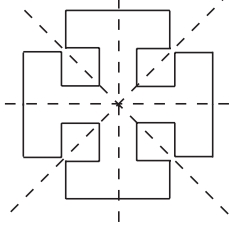
(e) 
Order 4

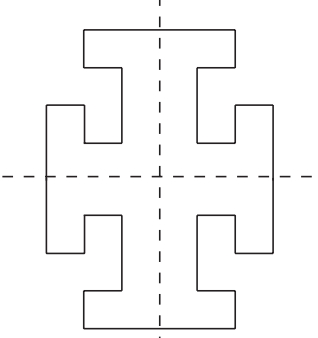
(f) 
Order 2

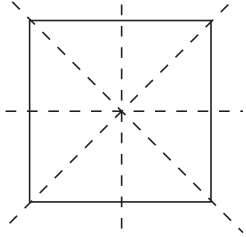
6. 

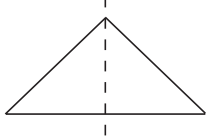
7 (a) (i) 
(ie. any isosceles triangle)

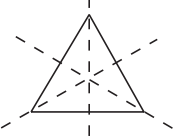
(ii) 
(ie. any equilateral triangle)

(b) No.

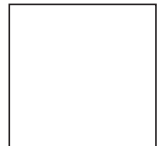
8. 
(eg. a square)

9. (a) 
Rotational symmetry order 2

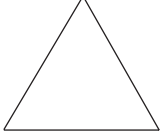
(b) 
Rotational symmetry order 3

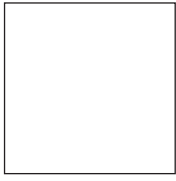
(c) 
Rotational symmetry order 4

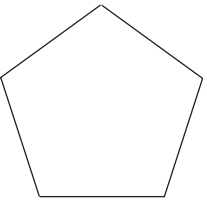
(d) 
Rotational symmetry order 5

10. (a) No

(b)

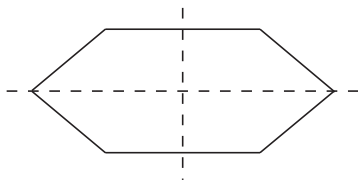

(c) No

11. Letter I has rotational symmetry.

12. Designs (a), (b) and (d) have line symmetry.

13. (a)

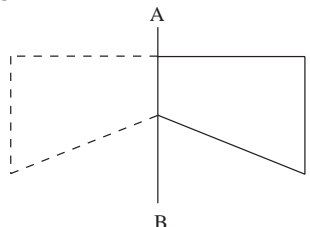

(b)

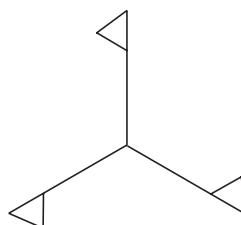

(c) Rotational symmetry of order 2.

3.3 Angle Geometry

1. (a) $a = 50^\circ$ (b) $x = 130^\circ$ (c) $b = 92^\circ$ (d) $a = 80^\circ$
 (e) $a = 111^\circ$ (f) $x = 82^\circ$ (g) $x = 110^\circ$ (h) $a = 45^\circ$
 (i) $x = 55^\circ$ (j) $a = b = 70^\circ$ (k) $a = b = c = 60^\circ$
 (l) $a = 50^\circ, b = 80^\circ$ (m) $a = 109^\circ$ (n) $x = 114^\circ$ (o) $x = 87^\circ$

2. (a) (i) $a = 70^\circ, b = 110^\circ$ (ii) $a = 53^\circ, b = 127^\circ$ (iii) $a = 48^\circ, b = 132^\circ$
 (b) b is equal to the sum of the two opposite angles in the triangle.
 (c) (i) $b = 105^\circ$ (ii) $b = 106^\circ$ (iii) $b = 135^\circ$

3.

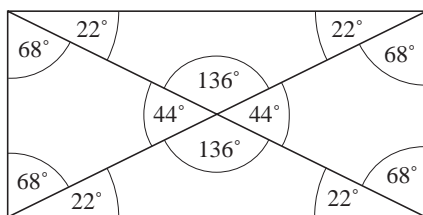

4. (a) $a = 75^\circ, b = 75^\circ, c = 30^\circ, d = 75^\circ$
 (b) $a = 60^\circ, b = 60^\circ, c = 30^\circ, d = 60^\circ, e = 60^\circ, f = 60^\circ, g = 30^\circ$
 (c) $a = 80^\circ, b = 45^\circ, c = 45^\circ, d = 55^\circ, e = 80^\circ$
 (d) $a = 30^\circ, b = 20^\circ, c = 10^\circ, d = 80^\circ, e = 80^\circ, f = 60^\circ$
5. (a) $a = 65^\circ, b = 80^\circ$ (b) $a = 40^\circ,$
 (c) $a = 60^\circ, b = 60^\circ, c = 60^\circ, d = 120^\circ, e = 30^\circ$
 (d) $a = 65^\circ, b = 65^\circ, c = 58^\circ, d = 90^\circ, e = 35^\circ$
 (e) $a = 90^\circ, b = 97^\circ, c = 41.5^\circ, d = 41.5^\circ, e = 69^\circ, f = 69^\circ, g = 104^\circ,$
 $h = 38^\circ$
 (f) $a = 60^\circ, b = 60^\circ, c = 60^\circ, d = 80^\circ, e = 100^\circ, f = 40^\circ, g = 40^\circ,$
 $h = 120^\circ, i = 38^\circ$

6. $a = 44^\circ, b = 68^\circ, c = 68^\circ, d = 112^\circ, e = 112^\circ, f = 68^\circ$
7. $a = 50^\circ, b = 40^\circ, c = 70^\circ, d = 20^\circ, e = 65^\circ, f = 50^\circ$
8. $a = 25^\circ, b = 110^\circ, c = 45^\circ, d = 65^\circ, e = 70^\circ, f = 25^\circ, g = 25^\circ$
9. (a) $9x = 180^\circ, x = 20^\circ$ (b) $3x - 30 = 180^\circ, x = 70^\circ$
 (c) $3x + 30 = 180^\circ, x = 50^\circ$ (d) $5x = 360^\circ, x = 72^\circ$
 (e) $4x + 20 = 180^\circ, x = 40^\circ$ (f) $4x = 360^\circ, x = 90^\circ$
 (g) $17x + 20 = 360^\circ, x = 20^\circ$ (h) $2x = 30^\circ, x = 15^\circ$
 (i) $5x + 90 = 360^\circ, x = 54^\circ$ (j) $10x + 80 = 180^\circ, x = 10^\circ$
 (k) $6x = 150^\circ, x = 25^\circ$ (l) $13x + 22 = 360^\circ, x = 26^\circ$
10. (a) order = 6 (b) (i) $\text{AOB} = 60^\circ$ (ii) Equilateral triangle
11. $\text{BCD} = 134^\circ$ $\text{ABC} = 77^\circ$

3.4 Angles with Parallel and Intersecting Lines

1. (a) $a = 38^\circ$, Opposite angles
 (b) $a = 57^\circ$, Opposite angles, $b = 123^\circ$, Straight line
 (c) $a = 60^\circ$, Straight line, $b = 120^\circ$, Opposite angles, $c = 60^\circ$, Opposite angles
 (d) $a = 100^\circ$, Straight line, $b = 100^\circ$, Opposite angles
 (e) $a = 145^\circ$, Straight line, $b = 35^\circ$, Opposite angles, $c = 145^\circ$, Opposite angles
 (f) $a = 50^\circ$, Corresponding angles
 (g) $a = 40^\circ$, Corresponding angles, $b = 140^\circ$, Straight line
 (h) $a = 60^\circ$, Straight line, $b = 60^\circ$, Corresponding angles, $c = 120^\circ$, Straight line
 (i) $a = 42^\circ$, Opposite angles, $b = 138^\circ$, Supplementary angles,
 $c = 42^\circ$, Corresponding angles
 (j) $a = 100^\circ$, Straight line, $b = 80^\circ$, Opposite angles, $c = 100^\circ$, Opposite angles
 $d = 80^\circ$, Corresponding angles
 (k) $a = 25^\circ$, Opposite angles, $b = 155^\circ$, Straight line,
 $c = 25^\circ$, Corresponding angles
 (l) $a = 124^\circ$, Alternate angles, $b = 56^\circ$, Straight line
 (m) $a = 37^\circ$, Corresponding angles, $b = 143^\circ$, Straight line,
 $c = 37^\circ$, Opposite angles
 (n) $a = 56^\circ$, Corresponding then Opposite angles, $b = 124^\circ$, Straight line,
 $c = 124^\circ$, Corresponding then Opposite angles,
 (o) $a = 160^\circ$, Straight line, $b = 160^\circ$, Corresponding angles,
 $c = 20^\circ$, Alternate angles
2. (a) $a = 70^\circ, b = 140^\circ$
 (b) $a = 60^\circ, b = 110^\circ, c = 70^\circ, d = 120^\circ$
 (c) $a = 52^\circ, b = 128^\circ, c = 52^\circ, d = 128^\circ$
 (d) $a = 75^\circ, b = 105^\circ, c = 75^\circ, d = 105^\circ$

- (e) $a = 60^\circ$, $b = 80^\circ$, $c = 80^\circ$
 (f) $a = 70^\circ$, $b = 50^\circ$, $c = 60^\circ$, $d = 70^\circ$, $e = 70^\circ$
 (g) $a = 74^\circ$, $b = 100^\circ$, $c = 41^\circ$, $d = 115^\circ$
 (h) $a = 48^\circ$, $b = 48^\circ$, $c = 132^\circ$, $d = 138^\circ$, $e = 42^\circ$, $f = 48^\circ$
 (i) $a = 64^\circ$, $b = 52^\circ$, $c = 64^\circ$
 (j) $a = 38^\circ$, $b = 52^\circ$, $c = 52^\circ$
3. (a) $4x = 180^\circ$, $x = 45^\circ$ (b) $10x = 360^\circ$, $x = 36^\circ$
 (c) $8x = 180^\circ$, $x = 22.5^\circ$ (d) $9x = 180^\circ$, $x = 20^\circ$
 (e) $6x = 180^\circ$, $x = 30^\circ$ (f) $8x = 180^\circ$, $x = 22.5^\circ$
4. AB is parallel to EF, GH is parallel to IJ
5. $a = 80^\circ$, $b = 50^\circ$, $c = 80^\circ$, $d = 50^\circ$
6. (a) AC and BD are parallel (b) $\angle BAC = 50^\circ$ because AEC is isosceles
7. (a) Square, Rectangle, Rhombus and Parallelogram
 (b) Rectangle, Parallelogram, Kite, Rhombus and Square
8. (a) 36° ; alternate angles (b) 54° ; angle POQ is 90°
9. (a) $p = 48^\circ$ (b) $q = 84^\circ$ (c) Alternate angles

3.5 Angle Symmetry in Polygons

1. (a) 108° (b) 120° (c) 135° (d) 144°
2. (a) 1260° (b) 1620°
3. (a) Square (b) Hexagon (c) Pentagon (d) Nonagon
 (e) Triangle (f) Decagon
4. Many possible solutions
6. (a) (i) No (ii) No (iii) No (b) (i) Yes (ii) No (iii) No
7. (a) 1260° (b) 180° , 360° , 540° , 720° , 900° , 1080°
 (c) $180n - 360$ (d) 2160° (e) 9
8. (a) $\frac{360}{n}$ (b) $180 - \frac{360}{n}$ (c) 162°
9. (a) 2 (c) (i) 5 (ii) 72°

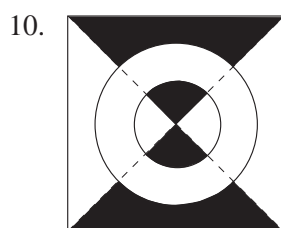

3.5

11. (a) 45° (b) 135°
12. (b) (ii) 120° (c) (i) 2 (ii) 6 (d) Cube

3.6 Symmetry Properties of 3D Shapes

2. (a) 4 (b) 2 (c) 4 (d) 4
3. (d) Not possible
5. 8 planes of symmetry along solid, 1 plane of symmetry through cross section
5 axes of symmetry

3.7 Compass Bearings

1. (a) Katie (b) James (c) Hester (d) Robin (e) Tom
(f) Simon (g) NE
2. (a) 100° (b) 155° (c) 177° (d) 355° (e) 207°
(f) 180°
3. (a) (i) 150° (ii) 090° (iii) 055° (b) 230 m
4. (a) 128° (b) 267° (c) 257° (d) 317° (e) 100°
5. (a) 535 m, 450 m (b) 38 m (c) 348° , 67 km (d) 293°
(e) 073° , 465 m
6. (a) 315° , 169 m (b) 203° , 400 km (c) 015° , 545 km
(d) 043° , 10 km (e) 348° , 8.5 km (f) 015° , 15.5 km
(g) 175° , 1430 m
7. 188° , 7000 km
8. (a) Kendal (b) Taunton
9. (5 km, 50°)
10. (a) (i) 20° (ii) alternate angles (iii) 48°
(b) (i) 052° (ii) 212° (iii) 312°
12. (a) 103°

3.8 Angles and Circles 1

1. (a) $a = 90^\circ$, $b = 65^\circ$
(b) $a = 72^\circ$, $b = 90^\circ$
(c) $a = 90^\circ$, $b = 76^\circ$, $c = 90^\circ$, $d = 74^\circ$
(d) $a = 90^\circ$, $b = 58^\circ$, $c = 90^\circ$, $d = 32^\circ$
(e) $a = 90^\circ$, $b = 49^\circ$, $c = 60^\circ$, $d = 60^\circ$, $e = 30^\circ$, $f = 30^\circ$, $g = 120^\circ$
(f) $a = 40^\circ$, $b = 100^\circ$, $c = 50^\circ$, $d = 50^\circ$, $e = 80^\circ$
(g) $a = 44^\circ$, $b = 44^\circ$, $c = 46^\circ$, $d = 46^\circ$, $e = 88^\circ$, $f = 44^\circ$
(h) $a = 70^\circ$, $b = 40^\circ$, $c = 140^\circ$, $d = 20^\circ$, $e = 20^\circ$

3. (a) $a = 90^\circ, b = 65^\circ$ (b) $a = 74^\circ$ (c) $a = 90^\circ, b = 90^\circ, c = 50^\circ, d = 75^\circ$
 (d) $a = 10^\circ, b = 170^\circ$
4. (a) $a = 20^\circ, b = 140^\circ$ (b) $a = 25^\circ, b = 25^\circ$ (c) $a = 30^\circ, b = 120^\circ$
 (d) $a = 100^\circ, b = 40^\circ, c = 40^\circ$
 (e) $a = 48^\circ, b = 84^\circ, c = 42^\circ, d = 42^\circ, e = 96^\circ$
 (f) $a = 75^\circ, b = 75^\circ, c = 15^\circ, d = 15^\circ, e = 150^\circ$
 (g) $a = 69^\circ, b = 69^\circ, c = 42^\circ, d = 69^\circ, e = 69^\circ$
 (h) $a = 28^\circ, b = 124^\circ, c = 70^\circ, d = 40^\circ, e = 16^\circ$
5. (a) $a = 30^\circ, b = 70^\circ, c = 70^\circ, d = 80^\circ$ (b) $a = 110^\circ, b = 140^\circ$
 (c) $a = 110^\circ, b = 140^\circ, c = 40^\circ, d = e = f = g = 70^\circ$
 (d) $a = b = 65^\circ, c = 60^\circ, d = 115^\circ$
6. (a) 5 (b) 7.8 (c) 12 (d) 10

3.9 Angles and Circles 2

1. (a) 30° (b) 120° (c) $c = d = 35^\circ$ (d) 146°
 (e) $f = 90^\circ, g = 55^\circ$ (f) $x = y = 43^\circ$
 (g) $a = 65^\circ, b = 25^\circ, c = 25^\circ, d = 65^\circ$ (h) $a = 27^\circ, b = 126^\circ, c = 63^\circ$
2. (a) $\text{OAB} = \text{OBA}, \text{BAC} = \text{BFC}, \text{OGA} = \text{OAG}, \text{OFC} = \text{OCF},$
 $\text{OCB} = \text{OBC}, \text{FCB} = \text{ACD} = \text{GAC}$
 (b) angles $\text{GAC}, \text{ACD}, \text{BCF}$
3. (a) $a = 120^\circ, b = 75^\circ$ (b) $c = 149^\circ, d = 123^\circ$
 (c) $a = 55^\circ, b = 125^\circ$ (d) $c = 140^\circ$ (e) $a = 48^\circ, b = 75^\circ$
 (f) $a = 75^\circ, b = 100^\circ$ (g) $a = 85^\circ, b = 30^\circ$ (h) $x = 160^\circ$
4. ABCD and PQR
5. (a) $a = 37^\circ, b = 108^\circ, c = 37^\circ$ (b) $a = 30^\circ, b = c = 75^\circ, d = 60^\circ, e = 30^\circ$
 (c) $a = 32.5^\circ, b = 147.5^\circ$ (d) 34°
6. (a) 50° (b) 22.5° (c) 40°
9. $x = 94^\circ, y = 28^\circ, z = 19^\circ$
10. (a) x (b) $90 - x$ (c) x (d) $2x$

3.10 Circles and Tangents

1. (a) 40° (b) $b = 55^\circ, c = 35^\circ$ (c) $a = b = c = 70^\circ$
 (d) $a = 11^\circ, b = 79^\circ, c = 79^\circ, d = 22^\circ$ (e) $a = 52^\circ, b = 104^\circ$
 (f) $a = b = c = 24^\circ, d = 62^\circ$
2. (a) 4.8 (b) $\frac{8}{3}$ (c) $x = 3.9, y = 4$ (d) $x = 7, y = 3.5$
 (e) $x = 4, y = 6$ (f) $x = 3, y = 2$
3. (c) 6
4. (b) 30°
5. $a = 74^\circ, b = 36^\circ, c = 32^\circ$
6. (a) $x = 65,$ (b) $y = 130,$ (c) $z = 50$

4 Trigonometry

4.1 Squares and Triangles

- (a) Isosceles (b) Scalene (c) Equilateral (d) Isosceles
(e) Scalene (f) Equilateral (g) Isosceles (h) Isosceles
- (a) Isosceles (b) Scalene
- (a) 25 cm^2 (b) 49 cm^2 (c) 100 m^2 (d) 1 cm^2
- (a) 4 m^2 (b) $10\,000 \text{ m}^2$ (c) 225 cm^2 (d) 289 cm^2
- (a) 3 cm (b) 5 m (c) 10 m (d) 8 cm (e) 1 cm (f) 20m
- 32 cm^2
- 72 cm^2
- 9 cm^2

4.2 Pythagoras' Theorem

- (a) 5 m (b) 13 m (c) 9 cm (d) 24 m (e) 10 m (f) 8 cm
(g) 15 m (h) 39 cm
- (a) 13.04 cm (b) 20.52 cm (c) 8.94 cm (d) 8.60 m (e) 7.14 cm
(f) 8.94 cm (g) 7.81 m (h) 11.83 m (i) 14.97 cm (j) 6.40 m
(k) 10.47 m (l) 7.07 m (m) 7.22 cm (n) 4.89 m
- (a) 320 m (b) 233.2 m (c) 86.8 m
- 2.5 m
- 2.44 m
- 9.54 m
- 10.77 m
- 4.24 m
- 2.06 m
- (a) 10.44 km (b) 14.32 km
- 6.71 m
- (a) 295 m (b) X

4.3 Further Work with Pythagoras' Theorem

1. (a) 7.14 (b) 7.07 (c) 5.39 (d) 7.75 (e) 10.95
(f) 14.28
2. (a) 14.14 (b) 1.94 (c) 1.29 (d) 3.12
3. (a) Yes (b) No (c) Yes (d) No
4. (a) 3.46 m (b) 1.73 m (c) 5.69 m
5. 122.47 cm
6. 332.75 cm
7. (a) 26.93 km (b) 26.93 km
8. 28.21 cm
9. 11.18 m , 11.18 m , 19.02 m
10. 41.22 m , 48.21 m
11. 7.75 cm ; 15.49 cm²
12. (a) 27.71 cm² (b) 173.21 cm² (c) 1.73 cm²

4.4 Sine, Cosine and Tangent

1. (a) hyp : BC ; adj : AC ; opp : AB
(b) hyp : DF ; adj : DE ; opp : EF
(c) hyp : GI ; adj : GH ; opp : HI
(d) hyp : LK ; adj : LJ ; opp : JK
(e) hyp : MO ; adj : MN ; opp : NO
(f) hyp : PQ ; adj : RQ ; opp : PR
2. (a) $\sin \theta = \frac{3}{5}$ $\cos \theta = \frac{4}{5}$ $\tan \theta = \frac{3}{4}$
(b) $\sin \theta = \frac{5}{13}$ $\cos \theta = \frac{12}{13}$ $\tan \theta = \frac{5}{12}$
(c) $\sin \theta = \frac{15}{17}$ $\cos \theta = \frac{8}{17}$ $\tan \theta = \frac{15}{8}$
(d) $\sin \theta = \frac{2}{2.5} = \frac{4}{5}$ $\cos \theta = \frac{1.5}{2.5} = \frac{3}{5}$ $\tan \theta = \frac{2}{1.5} = \frac{4}{3}$
(e) $\sin \theta = \frac{48}{50}$ $\cos \theta = \frac{14}{50}$ $\tan \theta = \frac{48}{14}$
(f) $\sin \theta = \frac{3.5}{12.5} = \frac{7}{25}$ $\cos \theta = \frac{12}{12.5} = \frac{24}{25}$ $\tan \theta = \frac{3.5}{12} = \frac{7}{24}$

3. (a) 0.500 (b) 3.732 (c) 1.308 (d) 0.407 (e) 0.649
 (f) 1.000 (g) 0.754 (h) 1.000 (i) 0.707 (j) 0.669
 (k) 0.686 (l) 0.707
4. (a) 60° (b) 90° (c) 24.2° (d) 55.2° (e) 48.6° (f) 23.1°
 (g) 45° (h) 30° (i) 63.4° (j) 82.0° (h) 15.1° (i) 79.2°
6. (a) $\cos \theta = \frac{z}{x}$ (b) $\sin \alpha = \frac{z}{x}$ (c) $\tan \theta = \frac{y}{z}$ (d) $\cos \alpha = \frac{y}{x}$
 (e) $\sin \theta = \frac{y}{x}$ (f) $\tan \alpha = \frac{z}{y}$

4.5 Finding Lengths in Right Angled Triangles

1. (a) 5.14 cm (b) 11.82 cm (c) 5.13 cm (d) 6.06 cm (e) 9 cm
 (f) 8.21 cm (g) 10.63 cm (h) 18.38 cm (i) 15.59 cm (j) 6.68m
 (k) 10.28 m (l) 20 m (m) 11.30 m (n) 4.16 m (o) 7.43 m
2. (a) 3.71 m (b) 1.50 m
3. (a) 1.73 m (b) 1.21 m (c) 1 m
4. 0.60 m
5. 143.4 m
6. (a) 386.4 km (b) 103.5 km
7. (a) 103.9 km (b) 60 km
8. 20.5 m to 35.3 m
9. (a) 12.11 cm (b) 13.46 cm (c) 6.55 cm (d) 7 cm
 (e) 26.86 m (f) 38.83 m (g) 13.68 cm (h) 30.66 cm
 (i) 1.51m
10. (a) 1.88 m (b) 2.92 m
11. 124.5 cm
12. (a) 3.83 cm, 22.98 cm² (b) $a \tan \theta$; $\frac{1}{2} a^2 \tan \theta$
13. 10.34 m
14. (a) 4.44 cm (b) 7.56 cm

4.6 Finding Angles in Right Angled Triangles

- (a) 53.1° (b) 71.6° (c) 75.5° (d) 47.0° (e) 33.1°
(f) 18.6° (g) 29.1° (h) 14.5° (i) 45.6° (j) 14.5°
(k) 45.5° (l) 23.8°
- 60°
- 11.5°
- (a) 21.8° (b) 68.2°
- (a) 48.2° (b) 11.18 m
- 040°
- 306°
- (a) $\alpha = 33.7^\circ$, $\beta = 19.4^\circ$ (b) 7.21 m, 10 m
- 5.74°
- (a) 12.37 cm (b) 72.08°
- (a) 7.62 m (b) 30.96°

4.7 Mixed Problems with Trigonometry

- 8.82 m
- 12.50 m
- 7.13°
- 1.03°
- (a) 381.6 m (b) 1.91°
- 7.85 m
- 7.20 m
- (a) 8.76 m (b) 6.02 m (c) 6.56 m (d) 5.09 m
- (a) 57.15 m (b) 12.02 m 10. 23.58° ; 938.6 m
- (a) 8.96 m (b) 38.5° (c) 6.72 m
- (a) (i) 373.4 m (ii) 20.4° (b) 200.2 m

4.8 Sine and Cosine Rules

- (a) 51.6° (b) 52.3° (c) 48.8° (d) 69.4° (e) 34.2° (f) 56.0°
- (a) 5.43 (b) 9.05 (c) 6.01 (d) 30.13 (e) 9.84 (f) 4.77
- (a) $A = 52.8^\circ$ $B = 42.2^\circ$ $a = 3.68$
 (b) $A = 19.9^\circ$ $B = 50.1^\circ$ $b = 12.16$
 (c) $B = 73^\circ$ $b = 4.45$ $c = 3.56$
 (d) $A = 44.2^\circ$ $B = 56.8^\circ$ $a = 4.33$
- (a) Yes (b) No, only one (c) No, impossible even for one (d) Yes
- $B = 65.6^\circ$, $C = 47.4^\circ$, $b = 123.6$
- $A = 34.1^\circ$, $C = 64.9^\circ$, $a = 6.25$
- (a) $B = 52.4^\circ$, $C = 67.6^\circ$, $a = 3.28$ (b) $B = 25.1^\circ$, $C = 4.9^\circ$, $a = 17.66$
 (c) $A = 45.5^\circ$, $B = 106.6^\circ$, $C = 27.9^\circ$
 (d) $A = 120.5^\circ$, $B = 36.9^\circ$, $C = 22.6^\circ$
 (e) $b = 8.41$, $A = 64.92^\circ$, $C = 60.08^\circ$
 (f) $c = 9.81$, $A = 28.45^\circ$, $B = 21.55^\circ$
- (a) 263.7 m (b) 192.9 m
- 2.65 miles
- (a) 117.3° (b) 10.2 m
- 60.02°
- (a) 23.35 cm (b) 62.66°
- 303.1°
- 45.98 (if no allowance made for inaccurate measurements) or 46.87
- 26.8 m
- (a) 80° (b) 6.99 cm

4.9 Angles Larger than 90°

- (a) $\frac{\sqrt{3}}{2}$ (b) $-\frac{1}{2}$ (c) $-\frac{1}{\sqrt{2}}$ (d) $-\frac{1}{2}$ (e) $-\frac{1}{\sqrt{2}}$ (f) -1
 (g) $\frac{1}{2}$ (h) $\frac{\sqrt{3}}{2}$ (i) $\frac{1}{\sqrt{2}}$ (j) $-\frac{\sqrt{3}}{2}$ (k) -1 (l) $-\frac{1}{2}$
- (a) 0.766 (b) -0.819 (c) -0.766 (d) 0.643 (e) 0.940
 (f) -0.766 (g) -0.985 (h) -0.985 (i) -0.259 (j) 0.985
 (k) 0.707 (l) -0.766

4. 6 ; -135° , -45° , 225° , 315° , 585° , 675°
5. 6 ; -300° , -60° , 60° , 300° , 420° , 660°
6. (a) -315.6° , -224.4° , 44.4° , 135.6°
(b) -156.4° , -23.6° , 203.6° , 336.4° (c) -90° , 270°
(d) -306.9° , -53.1° , 53.1° , 306.9°
(e) -246.4° , -113.6° , 113.6° , 246.4° (f) -180° , 180°
7. (a) 14.0° , 194.0° , 374.0° , 554.0° (b) 45° , 225° , 405° , 585°
(c) 153.4° , 333.4° , 513.4° , 693.4°
8. (a) 306.9° (b) 143.1° (c) 220° (d) 270°
9. (b) 180° (c) 120° , 720°
10. (a) $y = 5 \cos 4x$ (b) $y = 4 \sin\left(\frac{3x}{2}\right)$ (c) $y = 0.2 \cos 10x$
(d) $y = 0.7 \sin\left(\frac{x}{3}\right)$
13. $y = 10.5 \sin 30(x-4) + 10.5$; 19.6°C , 1.4°C
14. (b) $T = 98.6 + 0.3 \cos 15(t-17)$
15. (a) 60300° (b) 330° (d) $r = q + 180^\circ$
16. (b) 60° (c) 300° , 420°

5 Probability

5.1 Probabilities

1. (a) 0 (b) about 250 (c) about 250
2. (a) 50 (b) 50 (c) 0
3. (a) Impossible (b) Unlikely (c) Likely or Unlikely
(d) Likely or Unlikely (e) Unlikely (f) Likely (g) Likely
5. (a) 10 (b) 20 (c) 1000 (d) 600
6. About 900
7. (a) about 1500 (b) about 250
8. (a) 50 (b) 50 (c) 25 (d) 25

5.2 Simple Probability

1. (a) 0.1 (b) $\frac{1}{4}$ (c) $\frac{1}{2}$ (d) $\frac{4}{5}$
2. (a) 0.2 (b) 0.4
3. 0.98
4. $\frac{4}{5}$
5. (a) $\frac{4}{7}$ (b) not to snow
6. 0.99
7. (a) $\frac{2}{5}$ (b) 12
8. (a) 0.6 (b) 0.9 (c) 0.1
9. (a) $\frac{9}{20}$ (b) $\frac{10}{11}$ (c) $\frac{9}{13}$
10. No
11. 0.15
12. (a) C (b) B
13. (a) near to 0 (b) near to 1

5.3 Outcome of Two Events

2. VC, VS, MC, MS, RC, RS
3. GG, RG, GR, RR
4. (a) Nigel wins sit ups and Ben wins press ups
 (b) BJ, BN, BB, JB, JN, JJ, NB, NJ, NN (c) BJ, BB, JB, JJ
 (d) BJ, BN, BT, BB, JB, JN, JT, JJ, NB, NJ, NT, NN, TB, TN, TJ, TT
5. BS, BT, BD, BB, ST, SD, SS, TD, TT, DD
6. CD, CB, CC, DB, DD, BB
7.

| | | |
|---|----|----|
| | F | M |
| H | HF | HM |
| T | TF | TM |
| C | CF | CM |
8. HHH ; HHT, HTH, THH ; HTT, THT, TTH ; TTT
9. (b) $\frac{4}{9}$

5.4 Finding Probabilities Using Relative Frequency

4. $\frac{1}{4}$
5. (a) $\frac{4}{5}$
6. (a) $\frac{2}{7}, \frac{7}{10}, \frac{1}{4}, \frac{1}{5}, \frac{1}{3}, \frac{2}{3}$ (b) Andrew (c) Rachel (d) Charles
7. (a) $\frac{3}{8}$ (b) $\frac{5}{12}$ (c) $\frac{5}{24}$
8. (a) $\frac{4}{5}$ (b) 96

5.5 Determining Probabilities

1. (a) $\frac{1}{4}$ (b) $\frac{1}{4}$ (c) $\frac{1}{13}$ (d) $\frac{1}{13}$ (e) $\frac{4}{13}$
2. (a) $\frac{13}{54}$ (b) $\frac{13}{54}$ (c) $\frac{2}{27}$ (d) $\frac{2}{27}$ (e) $\frac{8}{27}$
3. (a) $\frac{1}{6}$ (b) $\frac{1}{6}$ (c) $\frac{1}{2}$ (d) $\frac{1}{2}$
4. (a) $\frac{1}{8}$ (b) $\frac{1}{8}$ (c) $\frac{1}{2}$ (d) $\frac{5}{8}$ (e) $\frac{1}{4}$ 5. $\frac{3}{8}$
6. (a) $\frac{2}{5}$ (b) $\frac{4}{5}$ (c) $\frac{1}{5}$ (d) $\frac{4}{5}$ (e) $\frac{9}{49}$ (f) $\frac{39}{49}$ (g) $\frac{10}{49}$
7. (a) $\frac{9}{25}$ (b) $\frac{6}{25}$ (c) $\frac{3}{5}$ (d) $\frac{16}{25}$
8. (a) $\frac{2}{5}$ (b) $\frac{1}{5}$ (c) 1 (d) $\frac{4}{5}$

9. (a) $\frac{2}{5}$ (b) $\frac{1}{5}$ (c) $\frac{1}{5}$
10. (a) $\frac{3}{10}$ (b) $\frac{2}{9}$ (c) $\frac{1}{8}$ (d) $\frac{3}{8}$
11. (a) $\frac{7}{30}$ (b) $\frac{23}{30}$
12. (a) $\frac{1}{2}$ (b) $\frac{1}{6}$
13. (a) $\frac{1}{200}$ (b) 20
14. (a) $\frac{3}{10}$ (b) $\frac{4}{5}$
15. (a) Mint (b) $p(\text{mint}) = \frac{2}{3}$, $p(\text{toffee}) = \frac{1}{4}$, $p(\text{pen}) = \frac{1}{12}$ (c) $\frac{1}{12}$ (d) 0

5.6 Probability of Two Events

1. (a) $\frac{1}{4}$ (b) $\frac{1}{2}$ (c) $\frac{1}{2}$
2. (a) $\frac{1}{12}$ (b) $\frac{1}{4}$ (c) $\frac{1}{4}$ (d) $\frac{1}{3}$ (e) $\frac{1}{2}$
3. (a) (i) $\frac{1}{6}$ (ii) $\frac{1}{9}$ (iii) $\frac{1}{2}$ (iv) $\frac{5}{18}$ (v) $\frac{5}{18}$ (b) 7
4. (b) (i) $\frac{1}{9}$ (ii) $\frac{1}{3}$ (iii) $\frac{8}{9}$ (c) $\frac{1}{9}$
5. (a) $\frac{1}{4}$ (b) $\frac{1}{2}$
6. (a) $\frac{1}{8}$ (b) $\frac{5}{8}$ (c) 5
7. (a) 6 (b) $\frac{2}{3}$ (c) $\frac{1}{3}$
8. (a) 400 (b) $\frac{1}{400}$ (c) $\frac{1}{20}$ (d) $\frac{1}{25}$
9. (a) $\frac{1}{4}$ (b) $\frac{1}{8}$ (c) $\frac{7}{8}$
10. (a) (i) 1, 2 ; 1, 3 ; 2, 2 ; 2, 3 ; 3, 2 ; 3, 3 (ii) $\frac{1}{3}$ (iii) $\frac{2}{3}$ (b) (i) 9
11. (a) $\frac{1}{5}$ (b) $\frac{2}{5}$ (c) AX, AY, AZ, BW, BX, BY, BZ, CW, CX, CY, CZ, DW, DX, DY, DZ, EW, EX, EY, EZ
12. (b) $\frac{1}{8}$
13. (b) $\frac{4}{9}$

5.7 Use of Tree Diagrams

- (b) $0.6 \times 0.6 = 0.36$; $0.6 \times 0.4 = 0.24$; $0.4 \times 0.6 = 0.24$; $0.4 \times 0.4 = 0.16$
(c) 0.16 (d) 0.36 (e) 0.48
- (a) $\frac{1}{6}$ (c) (i) $\frac{1}{36}$ (ii) $\frac{5}{18}$ (iii) $\frac{25}{36}$
- (a) $\frac{1}{4}$ (b) $\frac{1}{4}$ (c) $\frac{1}{2}$
- (a) $\frac{81}{100}$ (b) $\frac{99}{100}$ (c) $\frac{1}{100}$
- (a) $\frac{1}{4}$ (c) (i) $\frac{9}{16}$ (ii) $\frac{3}{8}$ (iii) $\frac{1}{16}$
- (b) (i) 0.54 (ii) 0.36 (iii) 0.04
- (a) (i) 0.2 (ii) 0.4 (b) (i) 0.48 (ii) 0.08
- (a) (i) 0.2704 (ii) 0.2304 (iii) 0.4992 (b) (iii)
- (a) 0.56 (b) 0.38 (c) 0.04 (d) 0.64
- (a) $\frac{7}{18}$ (b) $\frac{1}{36}$ (c) $\frac{3}{4}$
- (b) (i) $\frac{1}{4}$ (ii) $\frac{1}{2}$ (iii) $\frac{3}{8}$
- (b) 0.52
- (a) $\frac{7}{13}$ (b) $\frac{43}{91}$
- (b) $\frac{3}{14}$
- (a) 0.6 (b) 0.16
- (a) $\frac{1}{216}$ (b) $\frac{5}{216}$ (c) $\frac{5}{72}$ (d) $\frac{2}{27}$

5.8 Multiplication for Independent Events

- NI - not independent I - independent (a) NI (b) I (c) I
(d) NI (e) NI (f) NI
- (a) (i) $\frac{5}{8}$ (ii) $\frac{3}{8}$ (iii) $\frac{25}{64}$ (iv) $\frac{9}{64}$ (v) $\frac{15}{64}$ (vi) $\frac{15}{64}$
(b) (i) $\frac{9}{64}$ (ii) $\frac{15}{32}$ (iii) $\frac{17}{32}$

3. (a) (i) $\frac{7}{10}$ (ii) $\frac{3}{10}$ (iii) $\frac{9}{100}$ (iv) $\frac{49}{100}$ (v) $\frac{21}{100}$
 (vi) $\frac{21}{100}$ (b) (i) $\frac{49}{100}$ (ii) $\frac{21}{50}$ (iii) $\frac{29}{50}$
4. (a) $\frac{1}{4}$ (b) $\frac{1}{6}$
5. (a) 0.06 (b) No
6. (a) 0.72 (b) 0.02 (c) 0.08
7. (a) 0.1 (b) 0.4 (c) 0.4 (d) 0.1
8. (a) 0.42 (b) 0.16
9. (a) $\frac{1}{49}$ (b) $\frac{36}{49}$ (c) $\frac{12}{49}$ (d) $\frac{1}{343}$
10. (a) No (b) $\frac{171}{250}$ (c) $\frac{283}{1000}$
11. (a) 0.003 (b) 0.833
12. (a) $\frac{1}{25}$ (b) $\frac{8}{25}$
13. (a) 0.58 (b) 0.44
14. 0.04
15. (a) (i) $\frac{1}{6}$ (ii) $\frac{1}{36}$ (b) $\frac{13}{36}$

5.9 Mutually Exclusive Events

1. B ; C
2. (a) Yes (b) No (c) No (d) Yes (e) No
3. 0.3
4. $\frac{1}{6}$
5. (a) $\frac{3}{7}$ (b) 12 (c) 14
6. (a) $\frac{7}{20}$ (b) Not mutually exclusive
7. (a) $\frac{2}{3}$ (b) $\frac{11}{15}$ (c) $\frac{3}{5}$ (d) $\frac{3}{5}$
8. (a) $\frac{5}{8}$ (b) $\frac{11}{20}$ (c) $\frac{7}{40}$
9. (a) 0.1 (b) 0.7
10. Pink : $\frac{2}{3}$ Yellow : $\frac{2}{7}$ Black : $\frac{11}{35}$
11. (a) $\frac{13}{25}$ (b) $\frac{22}{25}$ (c) No (d) No (e) Yes : $\frac{12}{25}$
12. (a) 0.2 (b) 0.7 (c) 20
13. (a) 0.7 (b) 0.7 (c) 0.6 (d) not mutually exclusive
14. (a) (i) 0.25 (ii) 0.75 (b) (i) 0.4 (ii) not mutually exclusive

5.10 Tree Diagrams and Conditional Probability

- (a) $\frac{1}{7}$ (b) $\frac{3}{7}$ (c) $\frac{4}{7}$
- (a) (i) $\frac{1}{17}$ (ii) $\frac{13}{34}$ (iii) $\frac{19}{34}$ (b) (i) $\frac{1}{221}$ (ii) $\frac{188}{221}$ (iii) $\frac{32}{221}$
- $\frac{43}{91}$
- (a) 0.24 (b) 0.09
- (a) (i) 0.16 (ii) 0.06 (iii) 0.78 (b) 0.01
- (a) $\frac{1}{12}$ (b) $\frac{1}{4}$ (c) $\frac{3}{4}$
- (a) $\frac{11}{46}$ (b) $\frac{7}{69}$ (c) $\frac{1}{46}$ (d) $\frac{25}{69}$ (e) $\frac{8}{69}$
- (a) $\frac{585}{812}$ (b) $\frac{801}{4060}$ (c) $\frac{34}{203}$
- 0.52
- (a) $\frac{1}{4}$ (b) $\frac{1}{2}$ (c) $\frac{1}{2}; \frac{47}{108}$
- (b) 0.15
- (b) 0.42 (c) 0.4998
- (a) $\frac{7}{75}$ (b) $\frac{3}{76}$ (c) $\frac{7}{15}$
- (b) 0.384 (c) 0.388
- (a) $\frac{7}{11}$ (c) PP, CPP, PCP (d) $\frac{126}{165} \approx 0.764$

5.11 Using Venn Diagrams to Find Probabilities

- (i) (a) $\frac{7}{20}$ (b) $\frac{4}{20}$ (c) 1 (d) $\frac{9}{20}$
 (ii) (a) $\frac{4}{17}$ (b) $\frac{6}{17}$ (c) 1 (d) $\frac{7}{17}$
 (iii) (a) 0 (b) $\frac{1}{5}$ (c) $\frac{9}{10}$ (d) $\frac{7}{10}$
 (iv) (a) $\frac{1}{8}$ (b) $\frac{2}{5}$ (c) $\frac{3}{4}$ (d) $\frac{9}{40}$
- (a) $\frac{1}{26}$ (b) $\frac{7}{13}$ (c) $\frac{6}{13}$
- (a) 0.4 (b) 0 (c) 0.4

4. (a) $\frac{5}{6}$ (b) $\frac{1}{6}$ (c) $\frac{1}{3}$ (d) $\frac{1}{6}$

5. (a) $\frac{2}{5}$ (b) $\frac{1}{6}$ (c) $\frac{1}{2}$

6. (i) (a) $\frac{3}{40}$ (b) $\frac{29}{40}$ (c) $\frac{21}{40}$ (d) $\frac{1}{8}$ (e) $\frac{3}{5}$ (f) $\frac{1}{4}$

(ii) (a) $\frac{1}{12}$ (b) $\frac{47}{60}$ (c) $\frac{7}{12}$ (d) $\frac{7}{60}$ (e) $\frac{13}{20}$ (f) $\frac{11}{30}$

(iii) (a) 0 (b) $\frac{4}{5}$ (c) $\frac{31}{50}$ (d) $\frac{7}{50}$ (e) $\frac{16}{25}$ (f) $\frac{11}{50}$

(iv) (a) 0 (b) $\frac{9}{10}$ (c) $\frac{23}{50}$ (d) $\frac{1}{5}$ (e) $\frac{2}{3}$ (f) $\frac{13}{30}$

7. 0.558

6 Number system

6.1 Decimals

- (a) 0.7 (b) 0.8 (c) 0.3 (d) 0.05 (e) 0.21 (f) 0.42
 (g) 0.005 (h) 0.151 (i) 0.022 (j) 0.08 (k) 0.13
 (l) 0.016 (m) 0.5 (n) 0.04 (o) 0.321
- (a) $\frac{4}{10}$ (b) $\frac{3}{10}$ (c) $\frac{4}{100}$ (d) $\frac{32}{100}$ (e) $\frac{45}{100}$
 (f) $\frac{6}{100}$ (g) $\frac{8}{100}$ (h) $\frac{14}{100}$ (i) $\frac{8}{1000}$ (j) $\frac{147}{1000}$
 (k) $\frac{36}{1000}$ (l) $\frac{4}{100}$ (m) $\frac{1}{10}$ (n) $\frac{9}{1000}$ (o) $\frac{107}{1000}$
- (a) 5.6 (b) 3.3 (c) 7.8 (d) 6.42 (e) 7.17 (f) 3.73
 (g) 4.6 (h) 4.8 (i) 3.16 (j) 3.94 (k) 10.2 (l) 1.4
- (a) 1.51 (b) 0.424 (c) 0.282 (d) 0.839 (e) 1.102
 (f) 0.281 (g) 0.858 (h) 0.738 (i) 0.372 (j) 11.87
 (k) 12.291 (l) 17.48 (m) 8.73 (n) 130.65 (o) 50.006
- (a) hundredths (b) tenths (c) hundredths (d) tenths
 (e) thousandths (f) thousandths
- (a) £5.16, £3.08, £4.56, £5.50 (b) £9.15 (c) £2.11
- (a) £3.28 (b) £1.52 (c) £8.42 (d) £11.21 (e) £0.48
 (f) £1.27 (g) £0.64 (h) £320.11 (i) £84.21
- (a) £1.78 (b) £3.22
- (a) £2.40 (b) £3.50
- 1.87
- 76 cm
- 0.8 kg
- (a) 5 (b) 5p
- (a) 10.85 kg (b) 26.55 kg (c) 105 dollars

6.2 Multiplying and Dividing with Decimals

- (a) 47.4 (b) 632 (c) 4.16 (d) 1274 (e) 0.1658
 (f) 3.24 (g) 630 (h) 4700 (i) 32000 (j) 47000
 (k) 0.0068 (l) 0.82 (m) 0.192 (n) 0.014 (o) 180
- (a) 36 (b) 1410 (c) 10500 (d) 132000 (e) 6000
 (f) 10400 (g) 3.3 (h) 0.37 (i) 0.007 (j) 0.007
 (k) 0.171 (l) 0.13 (m) 10860 (n) 23600 (o) 0.099
 (p) 0.06 (q) 0.6 (r) 0.0035

6.2

3. (a) 40 (b) 2500 (c) 80 (d) 600 (e) 13 200
(f) 3100 (g) 5200 (h) 4000 (i) 700
4. (a) (i) 360 p (ii) 60 000 p (iii) 4800 p (b) (i) £3.60 (ii) £600
(iii) £48 (c) 300 000
5. £124.87, £413, £107, £122.40
6. (a) 0.012 miles (\approx 21 yards \approx 63 ft \approx 760 inches \approx 19 m)
(b) (i) 5000 hours (ii) 90 hours
7. (a) (i) £108 (ii) £459 (iii) £810 (b) (i) £20 (ii) £88 (iii) £120
8. (a) 1500 (b) 500
9. 21 120 litres
10. (a) (i) £350 000 (ii) £560 000 (iii) £770 000 (b) 2000
11. (a) 540 (b) 50
12. (a) 6500 (b) 1037 (c) 7537
13. (a) $72 \times 100 = 7200$ (b) $60 \times 30 = 1800$
14. (a) (i) 18 (ii) 81 (b) 261

6.3 Fractions and Decimals

1. (a) (i) 18.64 (ii) 19 (b) (i) 1024.84 (ii) 1000 (c) (i) 16.04 (ii) 16
(d) (i) 181.44 (ii) 180 (e) (i) 16.82 (ii) 17 (f) (i) 0.08 (ii) 0.084
(g) (i) 0.01 (ii) 0.0096 (h) (i) 4.84 (ii) 4.8 (i) (i) 3.86 (ii) 3.9
2. (a) 48 600 (b) 48 637.01 (c) 48 637.0125 (d) 48 640
(e) 48 637.012 (f) 49 000
3. (a) 0.0047 (b) 48.2 (c) 20 (d) 4.86 (e) 18.42
(f) 21.80 (g) 15 000 (h) 0.005 (i) 0.00418
(j) 15 700 (k) 55 000 (l) 31.4 (m) 14.18 (n) 0.82
(o) 1.841 (p) 15.0 (q) 14.170 (r) 201
4. (a) 40 000, 45 000, 44 900, 44 850 (b) (i) 2 s.f. (ii) 1 s.f.
5. (a) 0.5 (b) 0.75 (c) 0.4 (d) 0.6 (e) 0.125 (f) 0.625
(g) 0.375 (h) 0.875 (i) 0.2
6. (a) 0.3333 (b) 0.1667 (c) 0.5714 (d) 0.1429 (e) 0.7143
(f) 0.8333
7. (a) 0.11111, 0.22222, 0.44444, 0.55556
(b) Recurring decimal which is the same as the numerator
(c) 0.7777..., 0.8888...

8. (a) 0.09091, 0.18182, 0.27273, 0.36364
 (b) 0.45455, 0.54545, 0.63636, 0.72727, 0.81818, 0.90909
10. (a) 0.8 (b) $0.096, \frac{4}{5}, 0.805, 0.85$

6.4 Long Multiplication and Division

1. (a) 345 (b) 684 (c) 513 (d) 9088 (e) 7308 (f) 15408
 (g) 2548 (h) 1920 (i) 23 328 (j) 10 164 (k) 2352
 (l) 5586 (m) 88 192 (n) 134 096 (o) 56 616
2. (a) 152 (b) 254 (c) 173 (d) 251 (e) 452 (f) 428
 (g) 123 (h) 35 (i) 12 (j) 32 (k) 24 (l) 153
 (m) 134 (n) 214 (o) 13
3. £2112
4. 700
5. 13
6. 350 kg
7. £333.33
8. (a) 13 (b) 7 ; 240
9. £154
10. (a) 35616 (b) 34132
11. 39
12. (a) 770 (b) (i) 19 (ii) 9

6.5 Estimating Answers

1. (a) 50 (b) 20 (c) 30 (d) 10 (e) 20 (f) 100
 (g) 60 (h) 0.2 (i) 0.04 (j) 2 (k) 20 (l) 2
2. Approximate answers are (a) 56 (b) 48 (c) 960 (d) 51
 (e) 600 (f) 540 (g) 10 (h) 7 (i) 20 (j) 120
 (k) 5 (l) 45
 Actual answers are (a) 56.01 (b) 54.20 (c) 1020 (d) 53.51
 (e) 623.4 (f) 545.5 (g) 11.11 (h) 7.634 (i) 18.59
 (j) 113.8 (k) 4.446 (l) 46.10
3. Approximate answers are (a) 2 (b) 0.5 (c) 3 (d) 7
 (e) 40 (f) 20 (g) 15 (h) 70 (i) 150
4. (a) 200 m (b) 233.28 m (c) 264.06 m
5. (a) Estimate 1200, Actual 1286 (b) Estimate 250 s, Actual 229 s
6. (a) About 40 ms^{-1} (b) 40.04, 39.67, 39.02
7. (a) 10 or 11, 11.08 km (b) about 480 km, 360 km
8. (a) Estimate £70, Actual £63.06 (b) Estimate £30, Actual £24.86
 (c) Estimate £40, Actual £38.19

9. (a) Estimate 72 , Actual 91.25 (b) Estimate 48 , Actual 48.5
 (c) Estimate 80 , Actual 86.02
10. (a) 60×30 (b) 1800 (c) 88
11. No ; it should be £7.02 (accurate answer: £7.03)

6.6 Using Brackets and Memory on a Calculator

1. (a) 97.2 (b) 27.40 (c) 3.55 (d) 2.69 (e) 0.767
 (f) 1.54 (g) 0.348 (h) 1.28 (i) 1.65 (j) 0.372
 (k) 0.0587 (l) 0.726
3. (a) 17.3 (b) 25.75 (c) 124
4. (a) 5.5 , 3.6591 , 3.1960 , 3.1625 , 3.1623 , 3.1623
 (b) 3.5 , 3.1786 , 3.1623 , 3.1623 , 3.1623 , 3.1623
 (c) Both sequences are converging to 3.1623, which is $\sqrt{10}$, but using 2 converges more quickly.
5. (a) (i) 141 , 141 (ii) 468 , 57 (iii) 3.2 , 28.8 , 3.2
 (b) (i) $3 \times 6 + 5 \times 51 + 15 \times 2 =$ (ii) $(3+6) \times 5 \times 2 =$
 (iii) & (iv) need all the brackets (v) $3 \times 4 \div (5+2) =$ (vi) $3 \times 2 \div (4 \times 6) =$
6. (a) 603.2 cm^2 (b) 258.1 cm^2
7. (a) (i) 2120575 mm^3 (ii) 5089 cm^3 (b) (i) 53.6 cm (ii) 88.4
8. 11.1
9. 7.00
10. (a) 4.29 (b) 4.652 (c) 50 (d) 2.5
11. (a) 36.6025 (b) 7.35
12. (a) Question 3 (b) Question 2
13. (a) (i) $v = 120 , u = 20 , t = 5$ (ii) $a = 20$ (b) $\boxed{=}$ needed after $\boxed{6}$
14. Last $\boxed{\times}$ should be replaced by $\boxed{\div}$, or insert brackets around 3.2×0.47

6.7 Upper and Lower Bounds

1. (a) $4.65 \leq x < 4.75$ (b) $41.5 \leq l < 42.5$ (c) $15.615 \leq A < 15.625$
 (d) $16.15 \leq d < 16.25$ (e) $11.675 \leq r < 11.685$ (f) $14.235 \leq m < 14.245$
 (g) $217.5 \leq w < 218.5$ (h) $15.195 \leq l < 15.205$ (i) $4.995 \leq w < 5.005$
 (j) $19.95 \leq v < 20.05$ (k) $18.085 \leq A < 18.095$ (l) $31.4505 \leq v < 31.4515$
2. (a) $41.5 \leq l < 42.5$, $31.5 \leq w < 32.5$
 (b) (i) $146 \leq \text{perimeter} < 150$ (ii) $1307.25 \leq \text{area} < 1381.25$
3. (a) $11.5 \leq \text{radius} < 12.5$
 (b) (i) $23 \leq \text{diameter} < 25$ (ii) $72.3 \leq \text{circumference} < 78.5$
 (iii) $415.5 \leq \text{area} < 490.9$

6.7

4. (a) 50 (b) 10 (c) 525 (d) 0.333... (e) 1.4
5. (a) 7.743 to 7.882 (b) 7.782 to 7.844
6. 1.595 m^2 to 2.605 m^2
7. (a) $116\,865.25 \text{ cm}^2$, $116\,181.25 \text{ cm}^2$ (b) 20989 cm^2
8. 0.0044 to 0.0064
9. 68.5 miles, 71.5 miles
10. (a) $54.11 \leq \text{area} < 56.75$, $26.08 \leq \text{circumference} < 26.70$,
(b) $5.383 \leq \text{radius} < 5.397$ (c) $2.417 \leq \text{radius} < 2.423$
11. (a) $2.4735 \leq \text{mass} < 2.4745$ (b) 1.62805, 1.62795
12. (a) 251 kg (b) 2 kg
13. (a) 29.5 cm (b) $18.35 \leq \text{length} < 18.45$
14. 210 g, 200 g
15. 2 m 97 cm
16. (a) 3.65 cm, 3.65 cm (b) 15 cm, 14.6 cm (c) (i) Two
(d) (i) No ; one significant figure
17. (a) 3.75 hours; 195 miles, 205 miles (b) 63.1 mph, 52.0 mph

6.8 Number System

1. Rational (terminating), Rational (recurring), Irrational, Rational (recurring), Rational (terminating), Irrational, Irrational, Rational (terminating), Irrational, Rational (recurring), Irrational, Rational (terminating)
2. (a) $\frac{49}{100}$ (b) $\frac{1}{3}$ (c) $\frac{7}{4}$ (d) - (e) $\frac{417}{1000}$ (f) $\frac{1}{9}$
(g) $\frac{1}{11}$ (h) $\frac{6}{11}$ (i) $\frac{1}{8}$ (j) $\frac{481}{500}$
3. (a) $\frac{41}{99}$ (b) $\frac{67}{1665}$ from $\frac{402}{9990}$ (c) $\frac{1}{7}$ (d) $\frac{8}{9}$ (e) $\frac{812}{999}$
(f) $\frac{5}{9}$ (g) $\frac{101}{111}$
5. Irrational, Irrational, Rational, Irrational, Irrational, Rational
10. $p + q$ can be rational or irrational
12. recurring, non-recurring, recurring, non-recurring, recurring
13. (a) 13, Rational (b) $\sqrt{61}$, Irrational (c) 3, Rational
(d) $\frac{5}{7}$, Rational

14. (b) 2^{-2} , $4^{\frac{1}{2}}$, 4^{-2}
15. (a) (i) any recurring decimal (ii) "and does not repeat itself"
 (b) Irrational, Rational $\left(\frac{5}{2}\right)$, Irrational, Rational $\left(\frac{1}{3}\right)$
16. (a) e.g. any square root larger than 16 and less than 25
17. (a) (i) 237 (ii) any n between $225 < n < 256$ is such that \sqrt{n} is irrational
 (b) 10.24 which has 3.2 or $\frac{16}{5}$ as a square root

6.9 Surds

1. (a) $1 + \sqrt{2} + \sqrt{3} + \sqrt{6}$ (b) $4 - 2\sqrt{3} + 2\sqrt{5} - \sqrt{15}$ (c) $\sqrt{3} - 3$
 (d) $-14 + 2\sqrt{11} + 7\sqrt{3} - \sqrt{33}$ (e) 11 (f) $30 + 4\sqrt{2}$ (g) $-16\sqrt{17}$
 (h) -7 (i) $1 - \pi$ (j) -4 (k) 4 (l) $\pi^2 - \pi$
 (m) $5 + \sqrt{2} + \sqrt{3} + 2\sqrt{6}$ (n) $-6 - 2\sqrt{10}$ (o) $7 + 4\sqrt{3}$
 (p) $8 - 2\sqrt{7}$ (q) $14 - 6\sqrt{5}$ (r) $7 + 5\sqrt{2}$
2. (a) $\frac{\sqrt{2}}{2}$ (b) $\frac{2}{5}\sqrt{5} + 1$ (c) $\frac{1}{2}(\sqrt{2} - \sqrt{6})$ (d) $-6 + 5\sqrt{2}$
 (e) $-\frac{1}{2}(5 + \sqrt{7} - 5\sqrt{3} - \sqrt{21})$ (f) $\frac{1}{22}(15 - 5\sqrt{2} - 3\sqrt{3} + \sqrt{6})$
 (g) $-\frac{1}{2} - \frac{1}{2}\sqrt{3}$ (h) $3 - 2\sqrt{2}$ (i) $\frac{4 - \sqrt{7}}{3}$ (j) $1 + \sqrt{22} + \sqrt{11} + \sqrt{2}$
 (k) $-(\sqrt{2} + \sqrt{3})$ (l) $\sqrt{3} + \sqrt{5} - \frac{1}{2}\sqrt{15} - \frac{5}{2}$
6. (a) Yes / No ; No / Yes ; No / Yes
 (b) 2π etc. or the square root of any number between 36 and 49
 (c) (i) Irrational (ii) Irrational
7. (a) (i) $x = 4$ etc. (ii) $y = 27$ etc.
 (b) (i) $\sqrt{2}, \sqrt{3}$ etc. (ii) $1 + \sqrt{2}, 1 - \sqrt{2}$ etc.
8. (a) (i) Rational, $\frac{3}{11}$ (ii) Irrational (iii) Rational, $\frac{21}{16}$ (b) $b = 8$ etc.
 (c) a

Answers

7 Mensuration

7.1 Units and Measuring

1. All \pm mm (a) 125 mm (b) 24 mm (c) 70 mm (d) 107 mm
(e) 7 mm
2. (a) km or miles (b) cm (c) mg or grams (d) kg (e) ml
(f) m^3 or litres
3. (a) 12 300 g (b) 4 700 mm (c) 164 mm (d) 3 400 m
(e) 370 cm (f) 6 000 ml

4.

| <i>Length in m</i> | <i>Length in cm</i> | <i>Length in mm</i> |
|--------------------|---------------------|---------------------|
| 4 | 400 | 4 000 |
| 3.11 | 311 | 3 110 |
| 1.5 | 150 | 1 500 |
| 3.74 | 374 | 3 740 |
| 8.62 | 862 | 8 620 |

5. (a) 15 (b) 10.3 (c) 130 (d) 45 (e) 56 (f) 18.2
(g) 6.6 (h) 3.4 (i) 11.2 (j) 2.6 (k) 36 (l) 84 (m) 220
6. (a) 850 ml (b) 5
7. (a) cm (b) m (c) m (d) cm/mm (e) m (f) cm/mm
(g) mm
8. 42 mm, 56 mm, 21 mm
9. (a) 4 cm (b) 7 cm (c) 11 cm (d) 0 cm (e) 1 cm (f) 1 cm
10. (a) m (b) 10 m

7.2 Estimating Areas

1. (a) 6 cm^2 (b) 10 cm^2 (c) 10 cm^2 (d) 14 cm^2
(e) 14 cm^2 (f) 7 cm^2
2. (a) 16 cm^2 (b) 14 cm^2 (c) 8 cm^2 (d) 12 cm^2
(e) 9 cm^2 (f) 12 cm^2
3. (a) 8 cm^2 (b) 9 cm^2 (c) between 10 cm^2 and 12 cm^2 (11 cm^2)
(d) between 8 cm^2 and 10 cm^2 (9 cm^2)
(e) between 6 cm^2 and 8 cm^2 (7 cm^2)
(f) between 16 cm^2 and 18 cm^2 (17 cm^2)
(g) between 10 cm^2 and 12 cm^2 (11 cm^2)
(h) between 9 cm^2 and 10 cm^2
(i) between 9 cm^2 and 11 cm^2 (10 cm^2)

4. The area of each island is between 25 km^2 and 27 km^2
(Remark: The left island is slightly bigger than the right one)
5. 47 cm^2

7.3 Making Solids Using Nets

2. (a) square-based pyramid (b) cuboid (c) tetrahedron (d) hexahedron
(e) hexagonal prism (f) octahedron

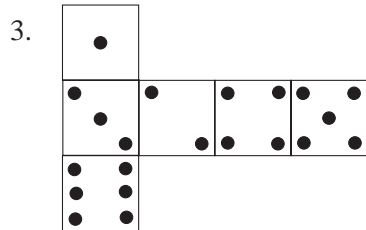

7.4 Constructing Nets

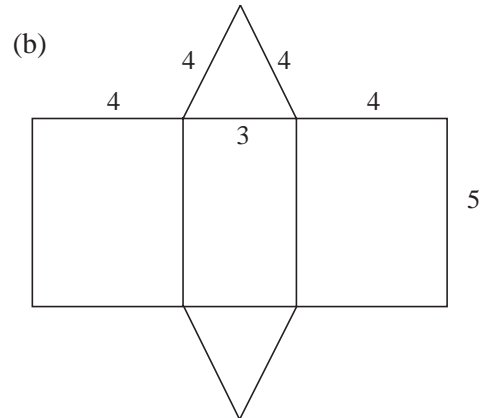
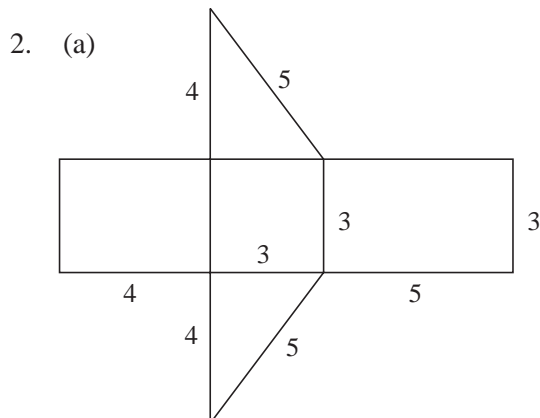
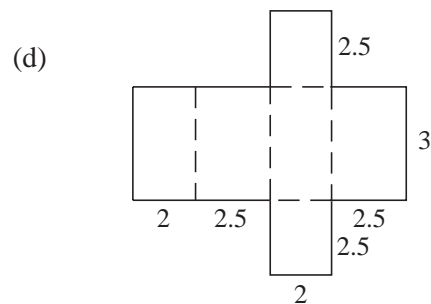
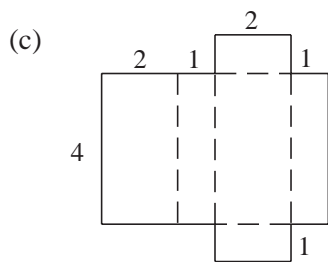
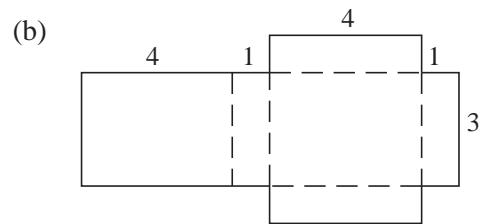
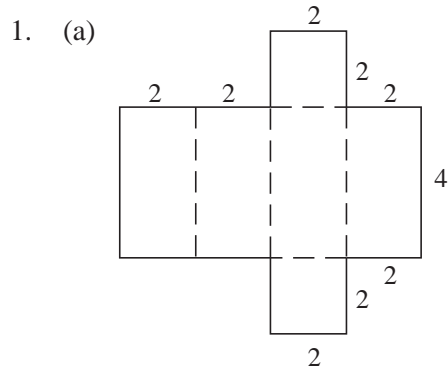

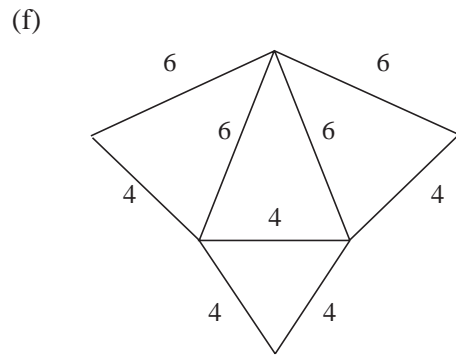
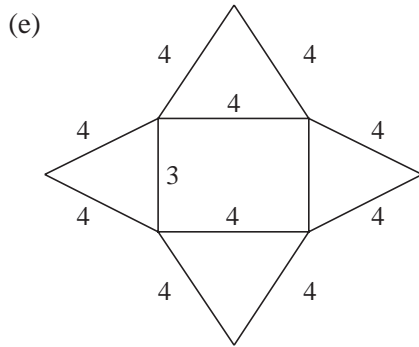
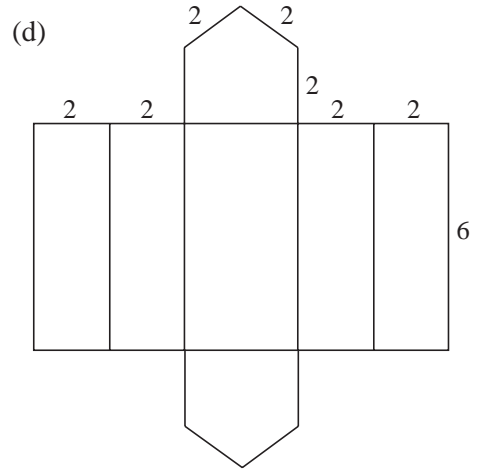
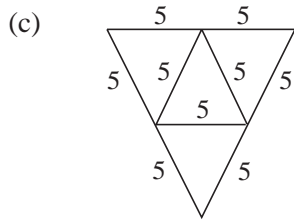

3. (b) Three ways; as in question and and .

Only the latter two configurations form a net for a tetrahedron.

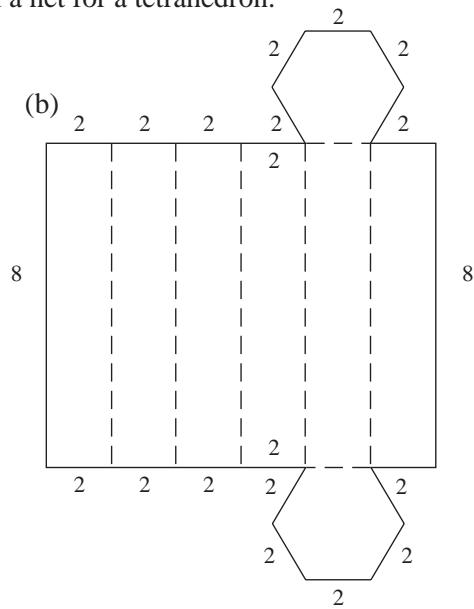
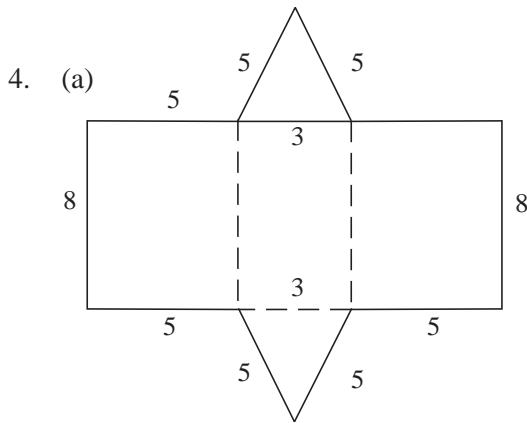

5. S

6. (a) Equilateral triangle (b) 60° (c)

7.5 Conversion of Units

1. (a) 7.5 cm (b) 252 lbs (c) 96 ounces (d) 75 inches (e) 33 lbs
 (f) 108 inches (g) 90 cm (h) 22.5 litres (i) 300 cm (j) 99 lbs
 (k) 15.75 pints (l) 202.5 litres (m) 14 pints (n) 48 pints
2. (a) 3.6 kg (b) 1.4 kg (c) 9.1 litres (d) 4.0 inches (e) 13.3 feet
 (f) 5.0 lbs (g) 13.0 stones (h) 11.1 gallons (i) 7.0 feet (j) 20.8 inches
 (k) 3.6 gallons (l) 1.7 litres (m) 2.7 kg (n) 7.1 feet
3.

| | | | | | |
|---------|----------------|-----------|---------|----|----|
| 30 | 43 | 18 | 29 | 32 | 14 |
| Norwich | Great Yarmouth | Lowestoft | Beccles | | |
4. (a) 65.6 km (b) 6.56 litres (c) 1.46 gallons
5. 0.43 litres of orange juice 1.36 kg of flour
 0.23 kg of butter 0.91 kg of mixed fruit
6. Total length = 354 inches , 885 cm, 8.85 m
7. James is both taller and heavier than Michael (James is 185 cm tall and weighs over 70 kg).
8. Jane picked the greater weight; she picked about 17.6 lbs.
9. The area of the sheet of glass is 2250 cm^2 . Its dimensions are 37.5 cm by 60 cm.
10. The first car consumes 0.1125 litres per km, and the second car consumes 0.12 litres per km. Hence, the first car is the more economical.
11. (a) 48 km (b) $K = \frac{M \times 8}{5}$ (c) = 62.5
12. (a) 48 000 g (b) 171 g (to the nearest gram) (c) 105.6 lbs
13. (a) cm (b) litres
14. (a) 160 cm (to the nearest cm) (b) 63.5 kg
15. (a) 0.2 kg (b) kg/cm^3
16. Yes he will. He needs less than 1 lb of flour for this recipe, and he has more than 1 lb of flour ($500 \text{ g} = \frac{1}{2} \text{ kg} \cong 1.1 \text{ lbs}$).

7.6 Squares, Rectangles and Triangles

- (a) 28 cm^2 (b) 12.4 cm^2 (c) 12 cm^2 (d) 9.46 cm^2
(e) 4.68 cm^2 (f) 14.4 cm^2
- (a) 14.4 cm , 12.96 cm^2 (b) 22.8 cm , 31.49 cm^2
(c) 38 cm , 60 cm^2 (d) 44 cm , 80 cm^2 (e) 32 cm , 36 cm^2
(f) 28 cm , 28 cm^2
- (a) 100 cm^2 (b) 60.5 cm^2 (c) 63 cm^2 (d) 24 cm^2
- (a) $42\,000 \text{ cm}^2$ (b) 41 blocks 5. $57\frac{1}{2}$ feet 6. 8 m^2
- $3.99 \text{ m}^2 + 1.5 \text{ m} = 5.49 \text{ m}^2$ 8. 40 cm^2 9. 1800 cm^2
- (a) (i) 3.9 m^2 (ii) 5.2 m^2 (b) 4.32 m^2
- (a) 38 cm (b) 40 cm^2 12. (a) 24 cm (b) 18 cm^2
- (a) 18 cm^2 (b) 30 cm^2 14. 22 cm^2
- $AB = 7 \text{ cm}$. Perpendicular height from C to AB = 2.4 cm ; area $\approx 8.4 \text{ cm}^2$.
- (a) (6.5, 4)

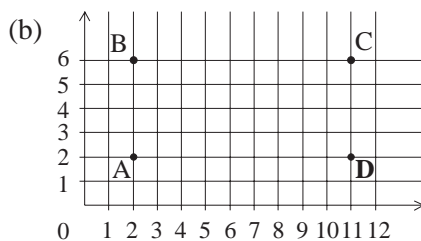

D is (11, 2)

- (c) (i) 26 cm (ii) 36 cm^2 (d) Rotational symmetry

7.7 Area and Circumference of Circles

- (a) $C = 31.4 \text{ cm}$ (to 1 d.p.)
 $A = 78.5 \text{ cm}^2$ (to 1 d.p.) (b) $C = 1.26 \text{ m}$ (to 2 d.p.)
 $A = 0.13 \text{ m}^2$ (to 2 d.p.)
- (c) $C = 3.77 \text{ m}$ (to 2 d.p.)
 $A = 1.13 \text{ m}^2$ (to 2 d.p.) (d) $C = 75.40 \text{ cm}$ (to 1 d.p.)
 $A = 452.39 \text{ cm}^2$
- (e) $C = 8.80 \text{ m}$ (to 2 d.p.)
 $A = 6.16 \text{ m}^2$ (to 2 d.p.) (f) $C = 62.83 \text{ m}$ (to 2 d.p.)
 $A = 314.16 \text{ m}^2$ (to 2 d.p.)
- (a) $r = 6.7 \text{ cm}$ (to 1 d.p.) (b) $r = 2.9 \text{ cm}$ (to 1 d.p.)
(c) $r = 4.7 \text{ cm}$ (to 1 d.p.) (d) $r = 5.4 \text{ cm}$ (to 1 d.p.)
- (a) 357 m (to the nearest m)
(b) $\left(\frac{50}{2}\right)^2 \pi + 50 \times 100 = 6963 \text{ m}^2$ (to the nearest m^2)

4. $(1.8)^2\pi - (0.5)^2\pi \approx 9.39 \text{ cm}^2$
5. (a) 12.57 cm^2 (to 2 d.p.) (b) 78.54 cm^2 (to 2 d.p.)
(c) 66 cm^2 (to the nearest cm^2)
6. (a) 28.27 cm^2 (b) 37.70 cm^2 7. $10 \times 7 - \left(\frac{5}{2}\right)^2\pi \approx 50.37 \text{ cm}$
8. $16 \times 8 - 2 \times 4^2 \times \pi \approx 27.47 \text{ cm}^2$
9. (a) 61.91 cm^2 (b) $r^2\pi - (4.2)^2 = 50 \text{ cm}^2 \Rightarrow r \approx 4.64 \text{ cm}$
10. (a) 5.78 m^2 (b) 1.6 m, 6.55 m^2
11. 201 cm^2 (to the nearest cm^2) 12. 707 cm^2 (to the nearest cm^2)
13. (a) $C = 50\pi = 157 \text{ cm}$ (to the nearest cm)
(b) 31848 revs ($C = 157 \text{ cm}$) or 31831 revs ($C = 50\pi$)
14. 16 times
15. (a) 3.82 m (b) 3.82 m is slightly less than 4 m and $\pi = 3.14$ is slightly more than 3 m, hence their product (which gives the length of the rope) is about 12 m.
(c) 4.52 cm^2
16. (a) 400 m (to the nearest m) (b) 10148.5 m^2 (to 1 d.p.)

7.8 Volumes of Cubes, Cuboids, Cylinders and Prisms

1. (a) 125 cm^3 (b) 360 cm^3 (c) 8.96 m^3
(d) 1005 mm^3 (to the nearest mm^3) (e) 2 m^3 (to the nearest m^3)
(f) 1508 cm^3 (to the nearest cm^3) (g) 504 cm^3 (h) 144 cm^3
(i) 2.4 m^3
2. (a) 0.25 m^3 (b) 0.20 m^3 (to the nearest m^3)
3. (a) 3.864 m^3 (b) 3.312 m^3
4. (a) 251327 cm^3 (b) 203.6 cm^3 , 2036 cm^3
(c) 249291 cm^3 (to the nearest cm^3)
5. (a) 120 cm^3 (b) 105 cm^3
6. (a) 168 cm^3 (b) 45 cm^3 (c) 176 cm^3 (d) 1600 cm^3
7. (a) 1200 cm^3 (b) 130 cm^3 8. $20\,000 \text{ cm}^3$
9. 67.5 m^3 10. 15 m^3 11. 26 m^3 (to the nearest m^3)

12. (a) 15 m^2 (b) 3 m^3 (c) 200 mm
13. (a) 462 cm^3 (to the nearest cm^3) (b) 3 cm
14. (a) 36.9 m^2 (b) 295.2 m^3 (c) 0.32 m 15. 1575 cm^3
16. (a) 7680 cm^3
 (b) (i) 50.3 cm (ii) 2011 cm^3 (to the nearest cm^3)
17. (a) 500 cm^3 (b) (i) 400 cm^3 (ii) 80%
 (c) (i) 42 cm^2 (ii) 9.5 cm (to the nearest mm)

7.9 Plans and Elevations

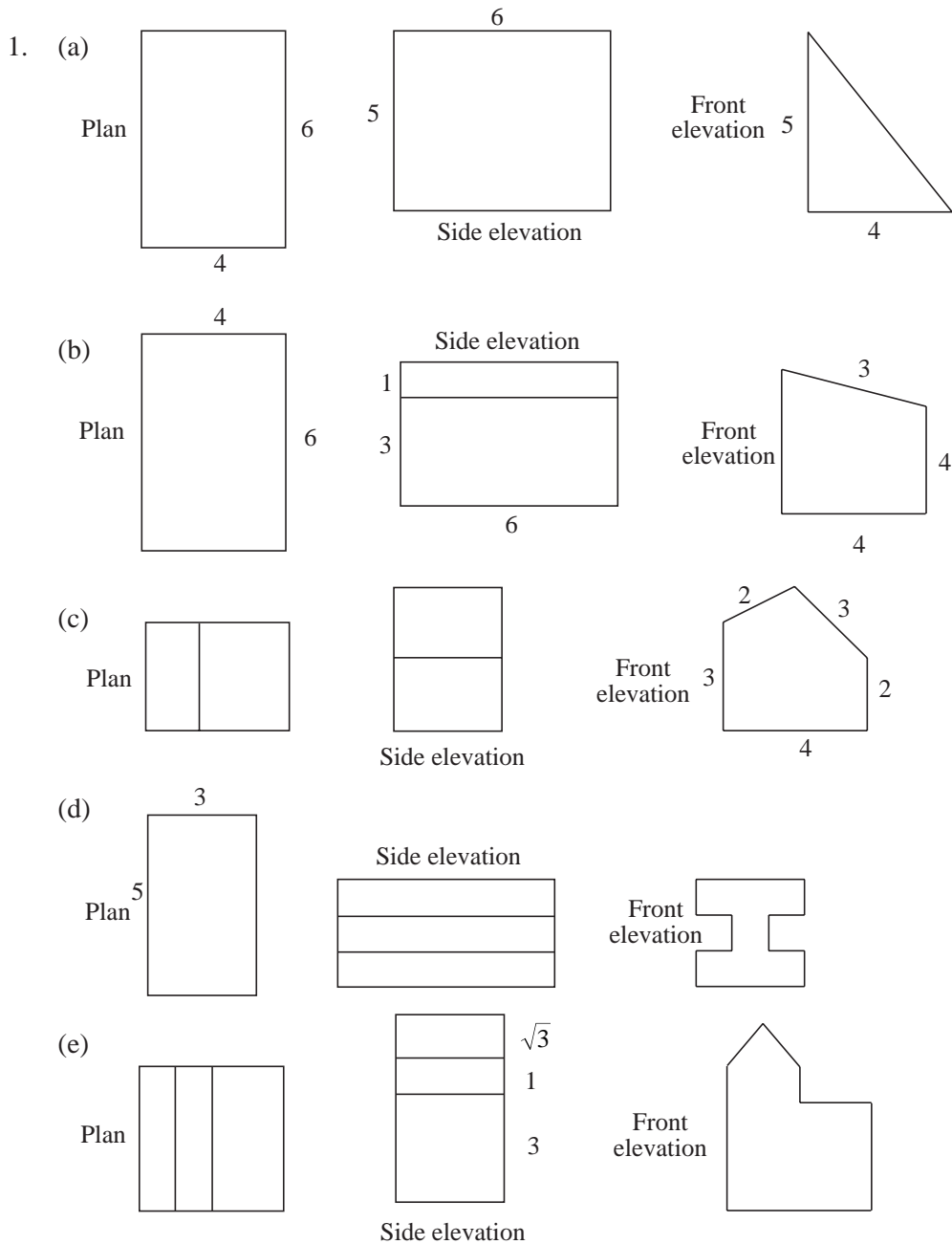

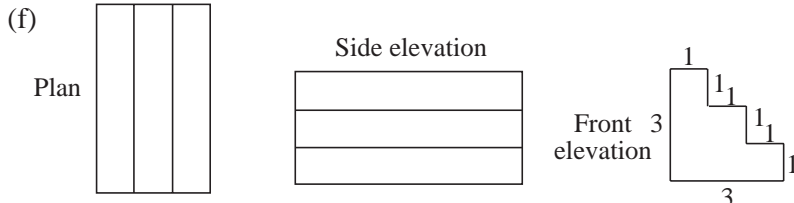
(f) 

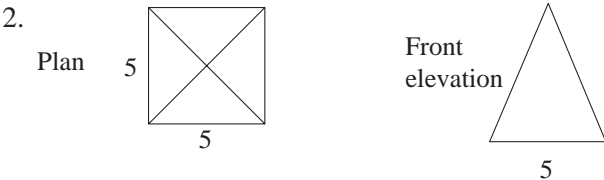
2. 

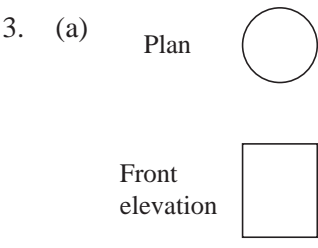
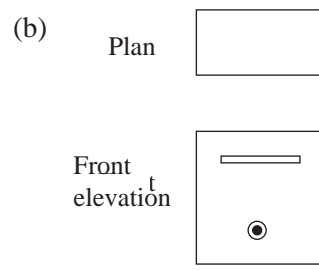
3. (a)  (b) 

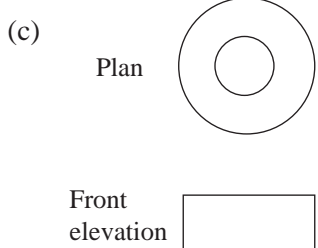
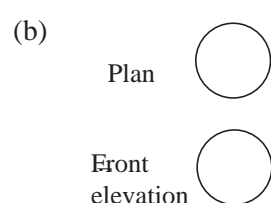
(c)  (b) 

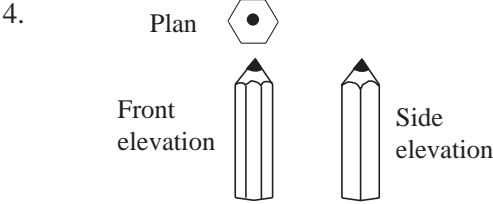
4. 

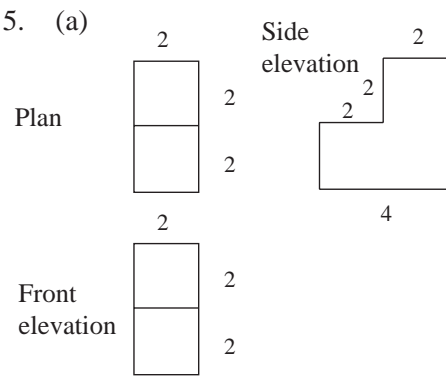
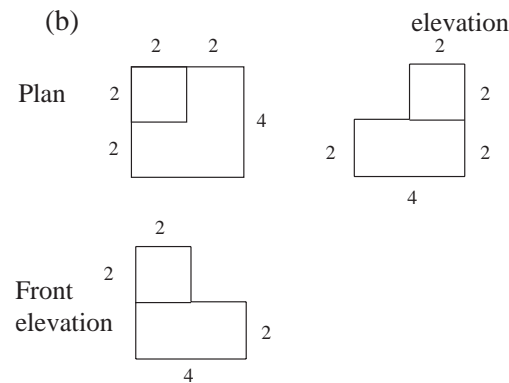
5. (a)  (b) 

7.10 Using Isometric Paper

7. (a) 34 cm (b) 44 cm
- ²
- (d) 2 cm, 3 cm, 4 cm (e) 24 cm
- ³

7.11 Discrete and Continuous Measures

1. (a) continuous (b) discrete (c) discrete (d) continuous
 (e) continuous (f) discrete (g) continuous (h) discrete
 (i) continuous (j) continuous (k) discrete (l) continuous
3. (a) 4.625 miles \leq 4.63 miles $<$ 4.635 miles (b) exact
 (c) 124.5 g \leq 125 g $<$ 125.5 g (d) 161.5 cm \leq 162 cm $<$ 162.5 cm
 (e) exact (f) 52.15 cm³ \leq 52.2 cm³ $<$ 52.25 cm³
 (g) 22.15 cm \leq 22.2 cm $<$ 22.25 cm (h) exact
 (i) 53.5 g \leq 54 g $<$ 54.5 g (j) exact

7.12 Areas of Parallelograms, Trapeziums, Kites and Rhombuses

1. (a) 12 m² (b) 5.5 m² (c) 80 cm² (d) 75 cm²
 (e) 72 cm² (f) 110 m² (g) 37.5 cm² (h) 7.2 m²
 (i) 10.2 cm²
2. (a) 3.5 m² (b) 4.5 m² (c) 17.5 m²
3. (a) 13.5 m² (b) 6 m² (c) 32 m² (d) 75 m²
4. 18 m² 5. 2500 cm²
6. (a) 4816 cm² (b) 4816 cm²
 (c) The area of the wasted plastic would be equal to the area of the kite (each of them would be 5600 cm², which is half the area of the rectangular sheet used to make the kite).
7. (a) 64 cm² (b) 58 cm² (c) 94.25 cm² (d) 44 cm²
 (e) 32 cm² (f) 44 cm²
8. 132 cm², 144 cm². Total area: 552 cm²
9. (a) (i) 36 cm² (ii) 72 cm² (iii) 90 cm²
 (b) No, since h is a side of a right-angled triangle whose hypotenuse is 6 cm long.
 (c) The maximum area is reached when $h = 6$ cm, and is equal to 108 cm².
 (The maximum area is reached when the parallelogram is actually a rectangle.)
10. (a) 28 cm² (b) 14 cm² (half the area of the parallelogram)
11. The kite ABCD is made of the two congruent triangles ABD and CBD. Hence, its area covers twice the area of each of these triangles.

7.13 Surface Area

- (a) 96 cm^2 (b) 136 cm^2 (c) 236 cm^2 (d) 62 cm^2
(e) 250 cm^2 (f) 30.4 cm^2
- (a) 108.38 cm^2 (to 2 d.p.) (b) 283 cm^2 (to the nearest cm^2)
(c) 207 cm^2 (to the nearest cm^2) (d) 69 m^2 (to the nearest m^2)
(e) 12.6 m^2 (to 1 d.p.) (f) 115 cm^2 (to the nearest cm^2)
- The surface area of each cylinder is $96\pi \text{ cm}^2$ ($A = 301.44$ when $\pi = 3.14$, and 301.60 using the π key on your calculator.)
(a) $V = 402 \text{ cm}^3$ (b) $V = 276 \text{ cm}^3$ (c) $V = 368 \text{ cm}^3$
- The volume of each cuboid is 64 cm^3 . The surface area of each cuboid is:
(a) 96 cm^2 , which is the smallest area, (b) 112 cm^2 , (c) 168 cm^2
- (a) $13\,195 \text{ cm}^2$ (to the nearest cm^2) (b) $35\,000 \text{ cm}^2$
- $6 \times 7^2 = 294 \text{ cm}^2$ 7. $\left(\sqrt{\frac{150}{6}}\right)^3 = 5^3 = 125 \text{ cm}^3$

- (a) 54 cm^2 (b) 66 cm^2 (c) 120 cm^2

9.

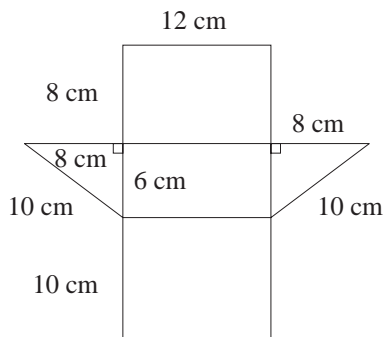

$$A = 336 \text{ cm}^2$$

- $11\,027 \text{ cm}^2$
(Total surface area = $(2 \times 25\pi \times 12) + 2(40^2\pi - 25^2\pi) + (2 \times 40\pi \times 12)$)
- (a) (i) $R(-1, 9, 0)$ (ii) $B(3, 9, 6)$ (b) (i) $PQ = 5 \text{ cm}$ (ii) $QR = 4 \text{ cm}$
(c) $CR = 6 \text{ cm}$, hence the total surface area is $2(4 \times 6 + 4 \times 5 + 6 \times 5) = 148 \text{ cm}^2$.

7.14 Mass, Volume and Density

- (a) 96 cm^3 (b) 88 cm^3 (c) 88 g
- (a) 8000 cm^3 (b) 0.75 g/cm^3 3. 0.794 g/cm^3

4. (a) $402\,123.86\text{ cm}^3$ (b) 402.124 kg
5. (a) 120 cm^3 (b) 2.5 g/cm^3 (c) 375 g (d) 1000 g (1 kg)
6. 80 g
7. (a) 60 m^3 (b) $60\,000\text{ kg}$ (c) volume: 52 m^3 ; mass: $52\,000\text{ kg}$
8. (a) 6.28 cm^2 (to 2 d.p.) (b) 1414 g (c) 40 cm
9. (a) 4188.79 cm^3 (b) 0.048 g/cm^3 (c) 83 g (to the nearest g)
10. (a) 6 g/cm^3 (b) 89 cm

7.15 Volumes, Areas and Lengths

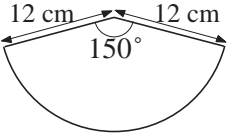
1. (a) 4.38 cm^2 (to 2 d.p.) (b) 5.27 cm^2 (c) 24.13 cm^2
 (d) 33.5 cm^2 (e) 64.14 cm^2 (f) 5.14 cm^2 (g) 4.47 cm^2
 (h) 12.57 cm^2 (i) 12.5 cm^2 (j) 94.6 cm^2
2. (a) 4.80 cm (b) 26.9 cm (c) $\theta = \frac{360^\circ}{2\pi} = 57.30^\circ$
 (d) $r = \frac{6 \times 15}{2\pi} = 14.32\text{ cm}$ (e) 9.42 cm (f) 4.2 cm
3. The volume needed to cover all the three edges and the top is 278 cm^3 .
4. 40.84 cm^2 5. (a) 13.3 m (b) 11.53 cm^2
6. (a)  The angle within the sector is equal to 150° .
 (b) 188.5 cm^2 (c) 286 cm^3
7. (a) 283 cm^3 (to the nearest cm^3) (b) 314 cm^3 (to the nearest cm^3)
 (c) 257 cm^3 (to the nearest cm^3) (d) 1.6 m^3 (to 1 d.p.)
 (e) 1018 cm^3 (to the nearest cm^3) (f) 2399 cm^3 (to the nearest cm^3)
 (g) 905 cm^3 (h) 262 cm^3 (to the nearest cm^3) (i) 500 cm^3 (j) 144 cm^3
8. $r = 6.08\text{ cm}$ (to 2 d.p.) 9. $d = 3\text{ cm}$ (to the nearest cm)
10. (a) 1131 cm^3 (to the nearest cm^3) (b) 1283 cm^3 (to the nearest cm^3)
 (c) 115 cm^3 (to the nearest cm^3) (d) 816 cm^3 (to the nearest cm^3)
11. 0.1 cm (to 1 d.p.) 12. 81.9 cm^3 (to the nearest cm^3)
13. 20.6 cm^3 (to 1 d.p.)
14. (a) 150 cm^2 (to the nearest cm^2) (b) $x = 129^\circ$ (to the nearest degree)
 (c) r may take one of the two values: 20 cm , 30 cm .

15. (a) $AB = 2.5 \cos 55^\circ = 1.43 \text{ m}$ (to 2 d.p.)
 (b) Area of the sector BDE is 3.82 m^2
 (c) 6.75 m^2 (d) 10 m (to the nearest m)
16. (a) $p = 7.57 \text{ cm}$ (to 2 d.p.) (b) 59°
17. (a) (i) $OX = 10.5 \text{ m}$ (ii) $AB = 20 \text{ m}$
 (b) The angle BOX is 44° (to the nearest degree) (c) 55 m^2

7.16 Dimensions

1. (a) $L^2 \Rightarrow$ Area (b) None (c) $L^3 \Rightarrow$ Volume
 (d) $L^2 \Rightarrow$ Area (e) $L^2 \Rightarrow$ Area (f) None
 (g) mixed dimensions (h) $L^3 \Rightarrow$ Volume (i) $L^3 \Rightarrow$ Volume
2. (a) Yes (b) No (c) No (d) Yes (e) Yes (f) Yes
3. $A = ab + ac + bc + cd$
4. $\sin \theta$ has dimension zero (it is the quotient of two lengths so it is a number)
5. $V = \frac{13}{17} \pi r^2 d$ (This is the only formula with dimension L^3 .)
6. $V = \pi R^2 h - \pi r^2 h$ (This formula is the only one with dimension L^3 .)
7. (a) The formulae that can give a volume are the ones with dimension L^3 :
 $\frac{4}{3} \pi r^3, \frac{3}{4} \pi r^3$.
- (b) The only formula that can give an area is the one with dimension L^2 :
 $\frac{4}{3} \pi r^2$.
8. $6x^2 + 4y^2$ has dimension L^2 and hence, can give a surface area.
 $x^3 + y^3$ has dimension L^3 and hence, can give a volume.
9. $V = \frac{\pi d^2 h}{4} + \frac{\pi d^2 a}{12}$, since it is the only formula with dimension L^3 .
10. (a) L (b) $L^2 \Rightarrow$ area
11. (a) Dimension $L \Rightarrow$ perimeter (b) Dimension $L^3 \Rightarrow$ volume
- 12.
- | | | | | | |
|----------|------------|-------------|-----------|-------|-----------------|
| $2\pi r$ | $4\pi r^2$ | $\pi r^2 h$ | πr^2 | lbh | $\frac{1}{2}bh$ |
| | | ✓ | | ✓ | |
13. The formulae which represent areas are the formulae with dimension L^2 .
 These are: $\pi ab, \pi(a+b)l$.
14. (iii) $\pi h(a+b)$. It is the only formula with dimension L^2 , the dimension of an area.

7.17 Areas of Triangles

1. (a) 12 cm^2 (to the nearest cm^2) (b) 11 cm^2 (to the nearest cm^2)
(c) 10 cm^2 (to the nearest cm^2) (d) 13 cm^2 (to the nearest cm^2)

2. (i) $A = 28 \text{ mm}^2$ (to the nearest mm^2), $\theta = 44^\circ$ (to the nearest degree)
(ii) $A = 56 \text{ cm}^2$ (to the nearest cm^2), $\theta = 61^\circ$ (to the nearest degree)
(iii) $A = 19 \text{ cm}^2$ (to the nearest cm^2), $\theta = 102^\circ$ (to the nearest degree)
(iv) $A = 15 \text{ cm}^2$ (to the nearest cm^2), $\theta = 44^\circ$ (to the nearest degree)

8 Data Handling

8.1 Tables and Timetables

- 0800
 - 0923
 - He should catch the next train and get off at Exeter St. Davids and walk.
 - For each journey - catch the 0723 from Paignton and change at either Newton Abbot or Exeter St. Davids - arriving at Bristol at 0932 or London at 1110.
- 2106
 - 1 hr, 39 mins.
 - Yes
 - The 2027 train from Reading.
- No
 - 1235
 - 1141
- 109 miles
 - 34 miles
 - 78 miles
 - 149 miles
 - The travelling distance would be reduced by 29 miles because Manchester is "en route" travelling from Birmingham to Leeds.
 - The route via Sheffield.
- St. Malo
 - 3984 km
 - 2781 km
 - Quimper is closest to St. Malo, and Ile de Re is closest to Calais.
- 9
 - 11
 - "D" grade.
- 7
 - 6
 - Years 7, 8, 9 and 11
 - Year 10
 - 43 students
- £305
 - £156
 - £276
 - £260
 - £45
- | | <i>Male</i> | <i>Female</i> | <i>Total</i> |
|-----------------|-------------|---------------|--------------|
| <i>Standard</i> | 64 | 48 | 112 |
| <i>Senior</i> | 20 | 8 | 28 |
| <i>Total</i> | 84 | 56 | 140 |
 - Men are more likely to become senior conductors than women.
- 51
 - 11
 - 52 outdoor and 50 indoor shows a roughly even split (only marginally in favour of outdoor sports)
- 4
 - 19
 - People seem to achieve better English results than French.
- 31
 - 90
 - 30%

8.2 Pictograms and Bar Charts

- 1996
 - 10
 - 7
 - 12
 - 1995
- 400
 - 250
 - 700
 - $5\frac{1}{2}$
 - 3300

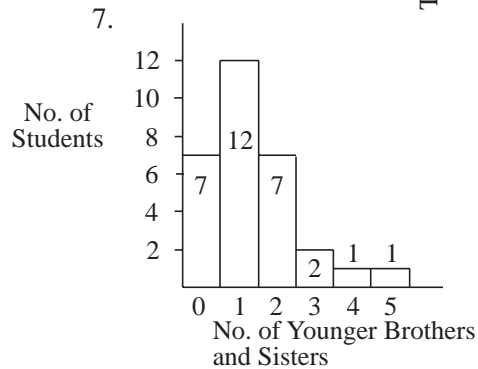
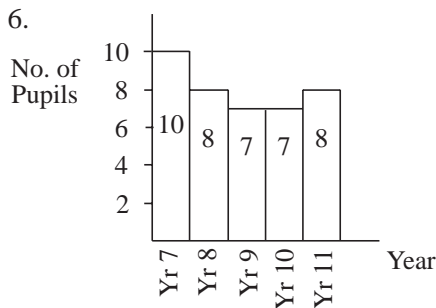
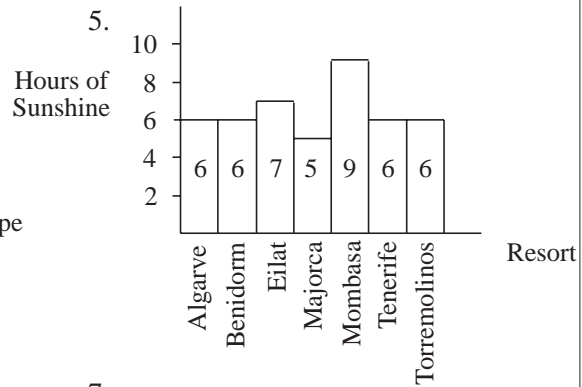
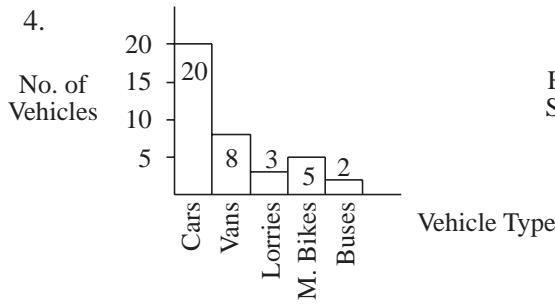
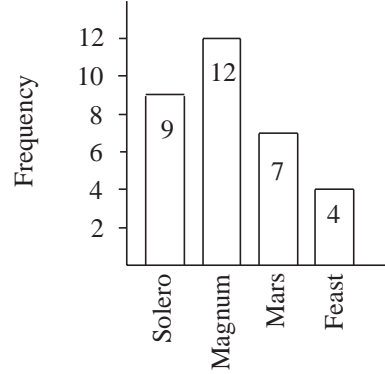
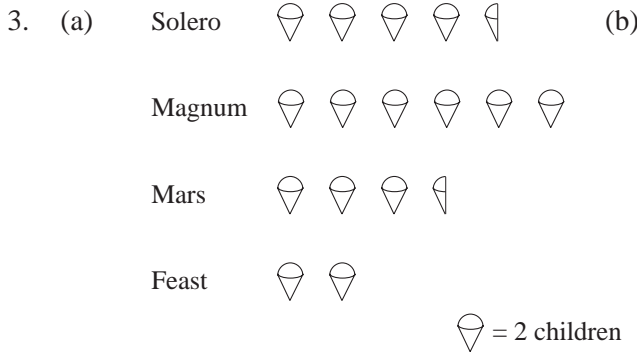

8. (a) (i) 90% (ii) About 97% (b) (i) 0% (ii) About 22%
 (c) The percentage of households with some sort of TV hasn't changed very much, but there has been an increase in the number of homes receiving satellite.

9. (a) 50 (b) 35

10. (a) 23 (b) We would expect there to be many more boys with shoe sizes around 8 and 9 than for 5 or 12, so the results are surprising.

11. (a) £14 (b) £375 (c) 16 coins
 (d) Only whole coins are used, and so the number is rounded up/down.

12.

| Colour | Tally | Frequency |
|--------|-----------------------|-----------|
| White | 1 | 11 |
| Blue | | 3 |
| Red | | 13 |
| Green | | 3 |

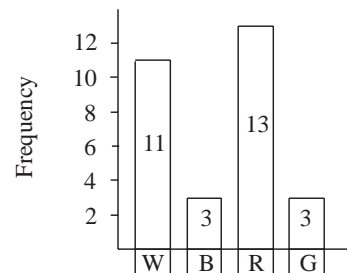

8.3 Pie Charts

1.

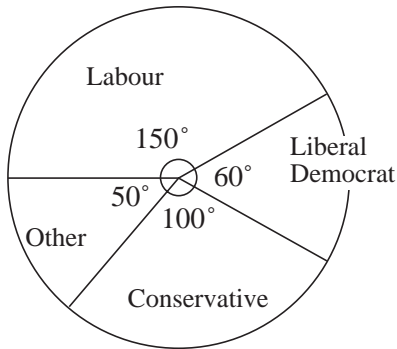

2.

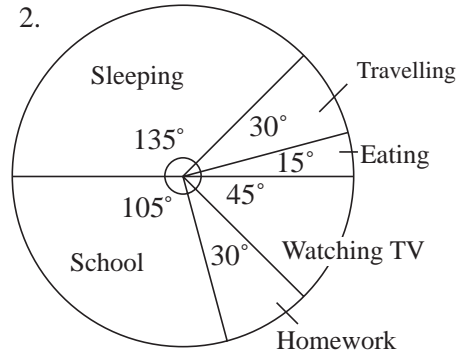

3.

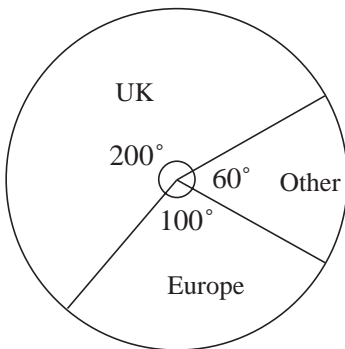

4.

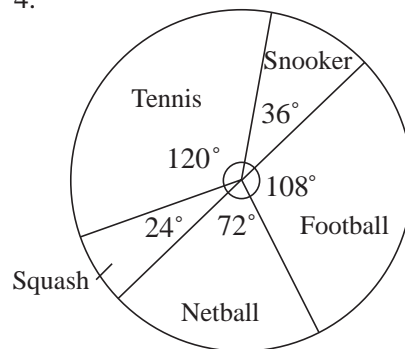

5. (a) 2 hours (b) 5 hours 6. (a) £10 (b) £15 (c) £35

7. (a) 96° (b) 6 (c) 30 (d) 13

8. Airmail = 50, 1st class = 320, 2nd class = 350

9. (a)

| Items | Angle of Sector |
|-----------------|-----------------|
| Bus fares | 48° |
| Going out | 100° |
| Clothes | 120° |
| Records | 60° |
| Others | 32° |
| Total of angles | 360° |

(b)

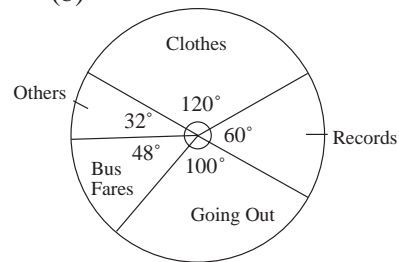

(c) $\frac{1}{3}$

10. (a)

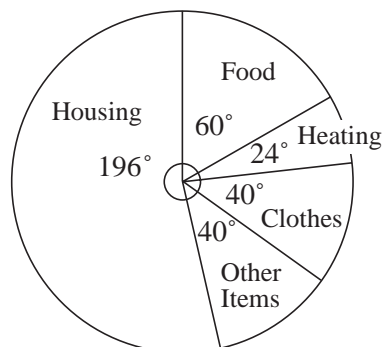

(b) Arthur spends more money on housing.

11. (a) (i) 81 litres (ii) $\frac{15}{100} = \frac{3}{20}$ (b)

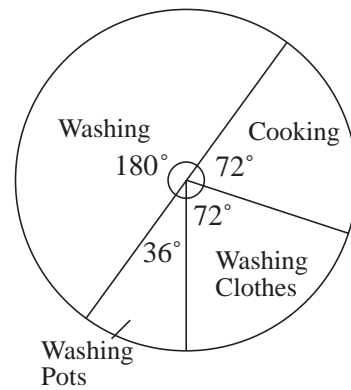

12. (a) (i) Five hundred thousand (ii) 200 000
 (b) (i) 39% (ii) Over 21 year olds. (iii) 0.61 or $\frac{61}{100}$

8.4 Line Graphs

1. (a) 4 cm (b) April (c) February & December (d) July & August
 2. (a) 40°C (b) 80°C (c) 20 mins after filling the mug. (d) 25 mins
 3. (a) 8 cm (b) 22 cm (c) 84 cm (d) 3 weeks

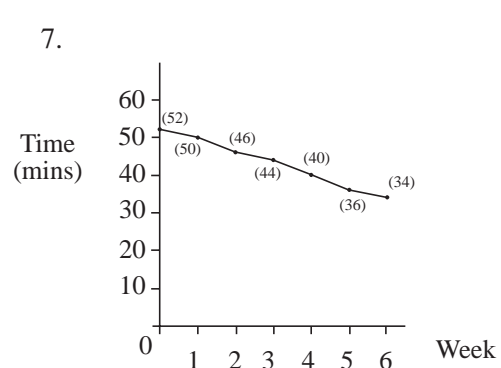
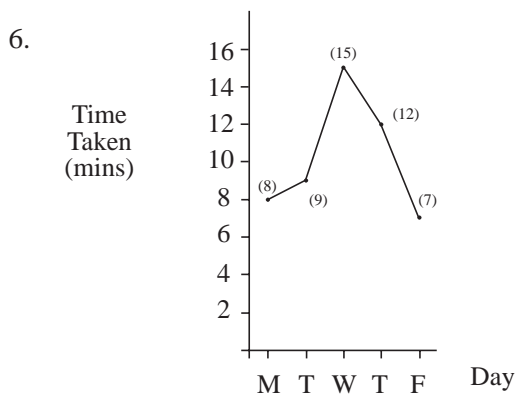
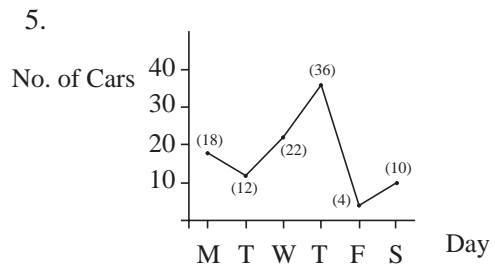
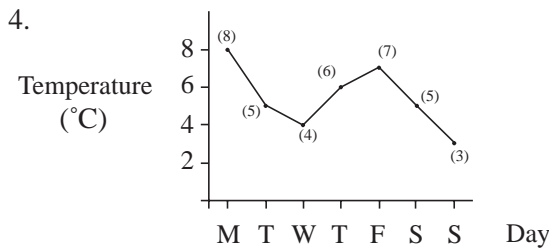

8.5 Questionnaires and Surveys

7. Question (A) gives genuine answers – although they may be difficult to analyse. Question (B) will give precise answers to just three aspects of life on this housing estate.

8. (a) Cycling and Swimming

10. (a) The percentage late is given by:

| Bus | Cycle | Car | Walk |
|-----|-------|-----|------|
| 27% | 20% | 22% | 13% |

so her conclusion is supported by the data.

(b) Choose pupils randomly, do not always use Tuesdays, increase sample size.

(c) Wrong – because you do not know whether there was an equal number of Y7 and Y8 pupils in the survey.

12. Sample is not random; sample value of 19% is not necessarily true for the whole population; they may only have travelled once on a bus in the last week – not each day.

8.6 Frequency Graphs

1. (a) 5 (b) 55 (c) 15 (d) 81 pupils in year group.

2. (a) 10 (b) 49 (c) 73 (d) largest = £549.99, smallest = £50.

3.

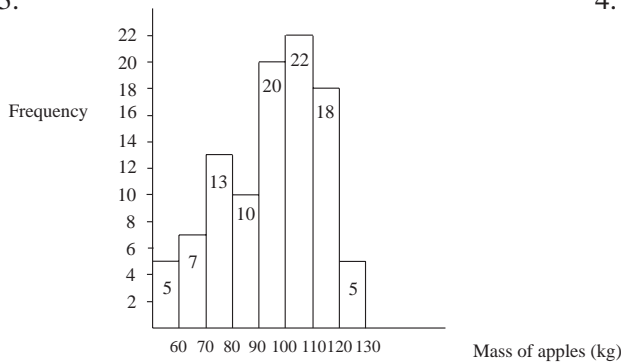

4.

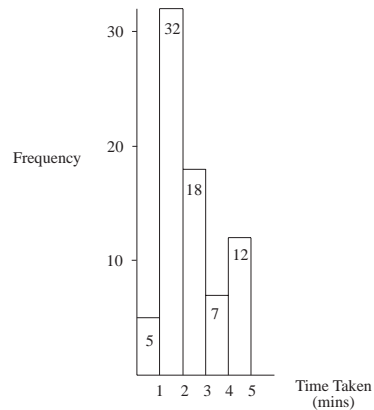

5.

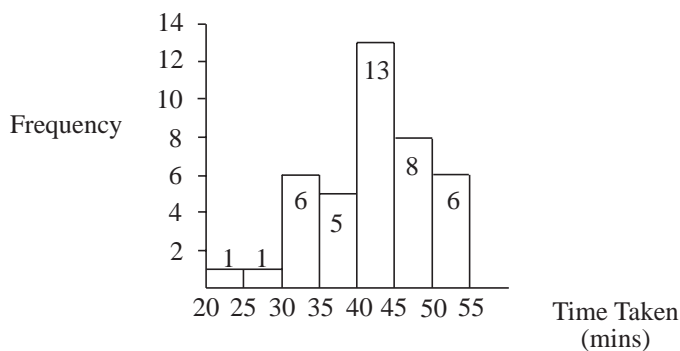

6.

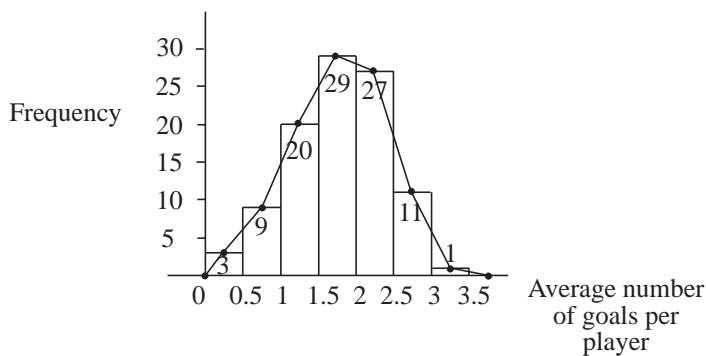

7. (a)

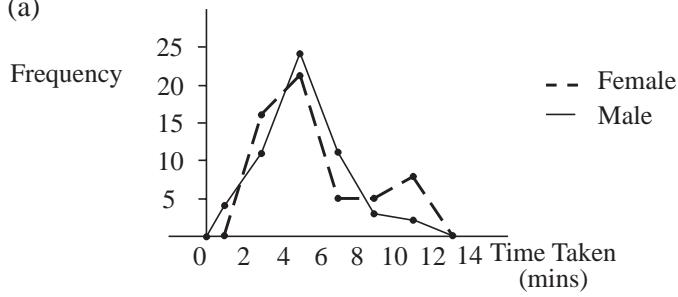

(b) Any reasonable answer.

8.

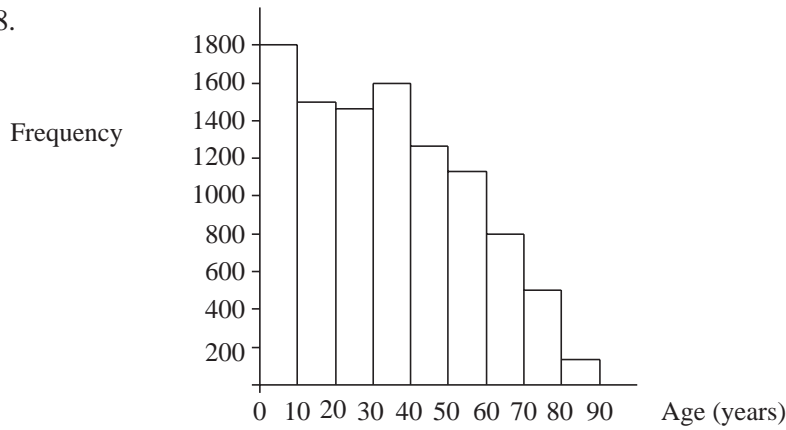

9. (a)

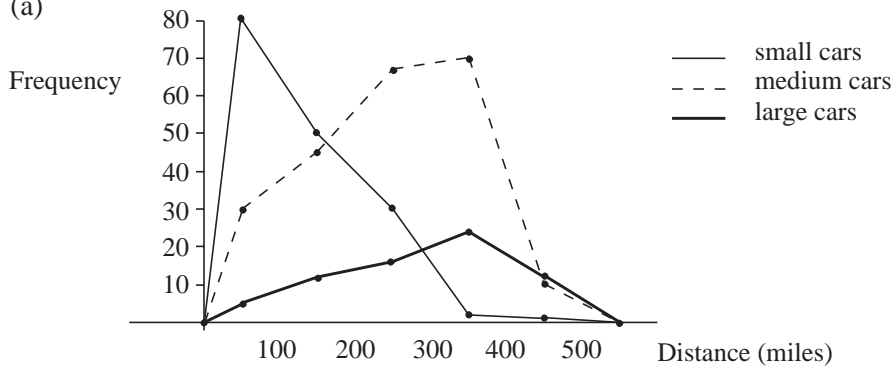

(b) There is a downward trend in the small cars, and an upward trend in the medium and large cars.

i.e. People use small cars for short journeys and the larger ones for long distances.

10.

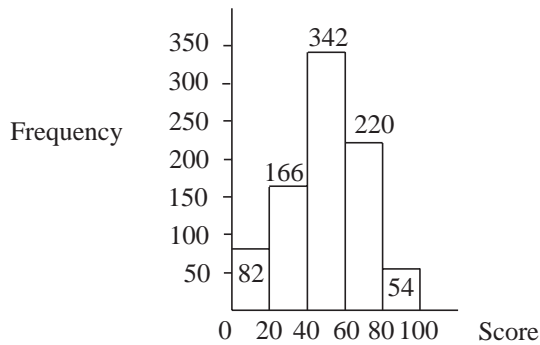

11. $62 + 70 = 132$ pupils.

12. (a) (i) $\text{prob.} = \frac{32}{200} = 0.16$ (ii) $\text{prob.} = \frac{106}{200} = 0.53$

(b)

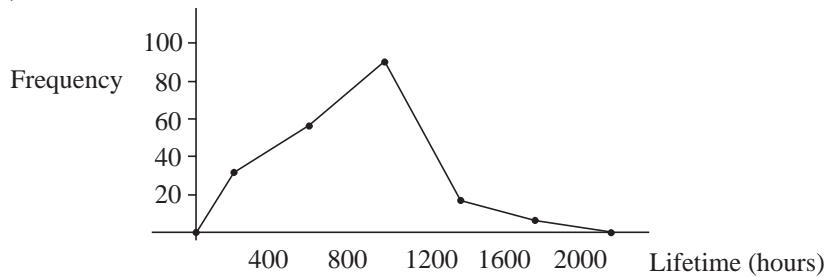

13. (a)

| Height | Frequency |
|-----------|-----------|
| 120 - 130 | 7 |
| 130 - 140 | 22 |
| 140 - 150 | 20 |
| 150 - 160 | 4 |

(b) The columns should be adjacent (no gaps).

The second column ($130 \leq h < 140$) should be 22 not 24.

(c) The last category.

14. (a)

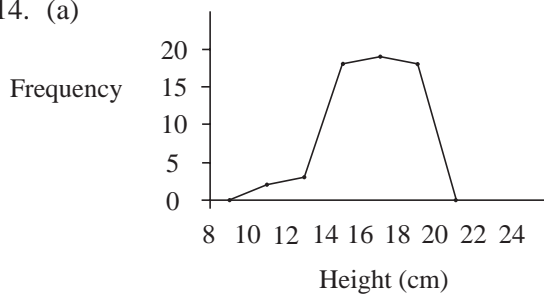

(b) Type B has an even spread of plants between 10 and 22, whereas Type A has more taller plants. The maximum number interval is 14 for Type B plants and 19 for Type A plants.

8.7 Histograms with Unequal Class Intervals

1. (a) 9 (b) 4 (c) 23

2. The area for the 20 - 25 interval is $0.9 \times 5 = 4.5$. This should be a whole number.

3.

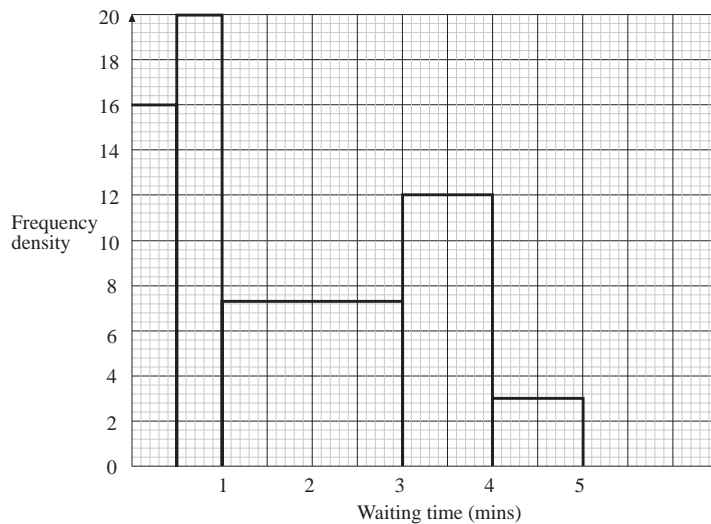

4.

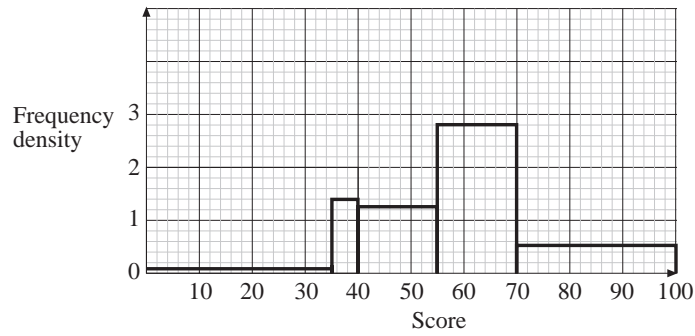

5.

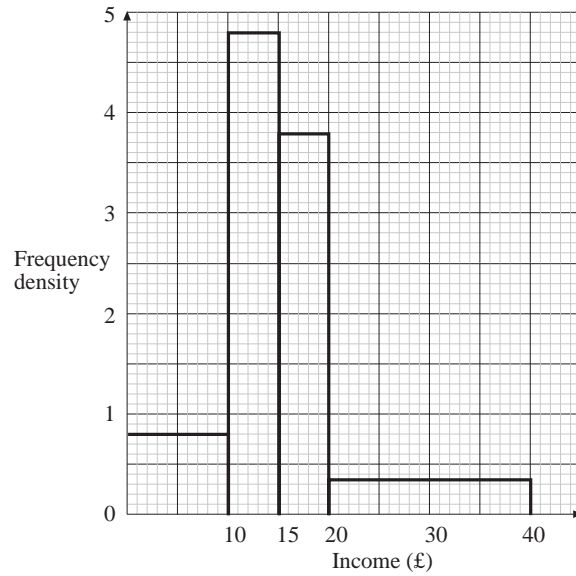

6. (a) The width is 5 because age 0–4 is actually age 0 up to age 5, i.e. 5 years.
 (b) The widths are (from the 2nd interval) - 5, 10, 20, 20, 5, 15, 20.
 (c)

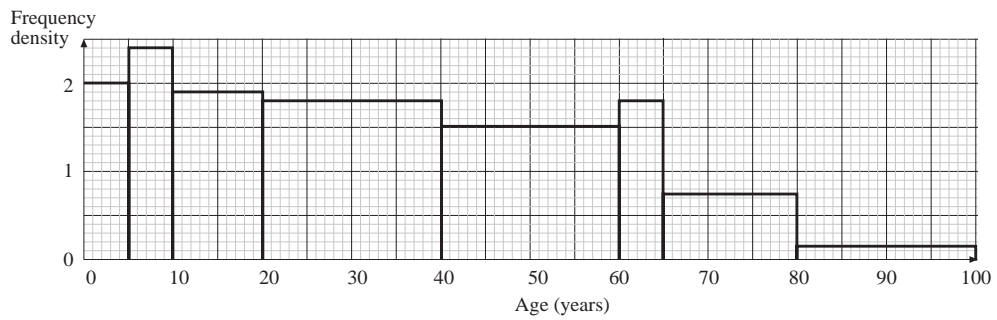

7.

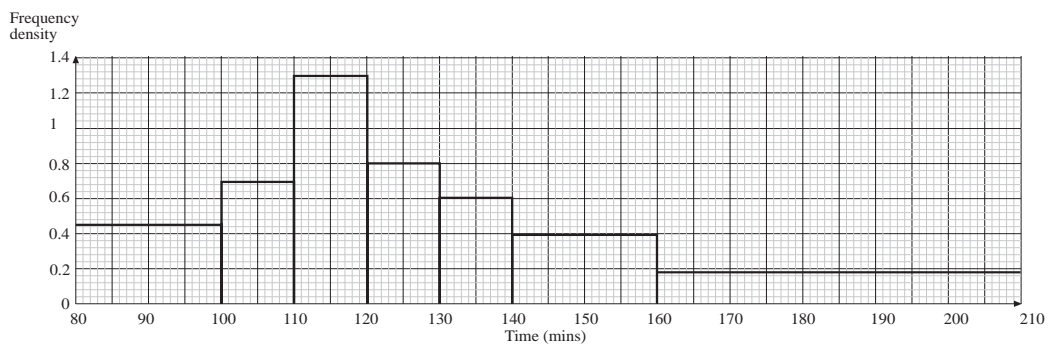

8. (a) Width of class intervals: 3, 6, 2, 10, 15.

(b)

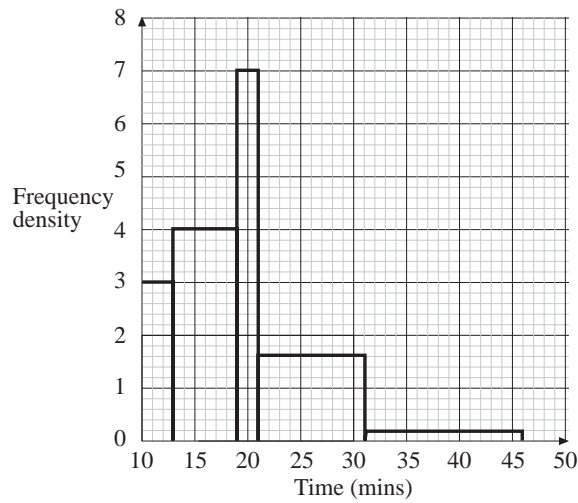

9. (a) 4 people (b) 23 people

10.

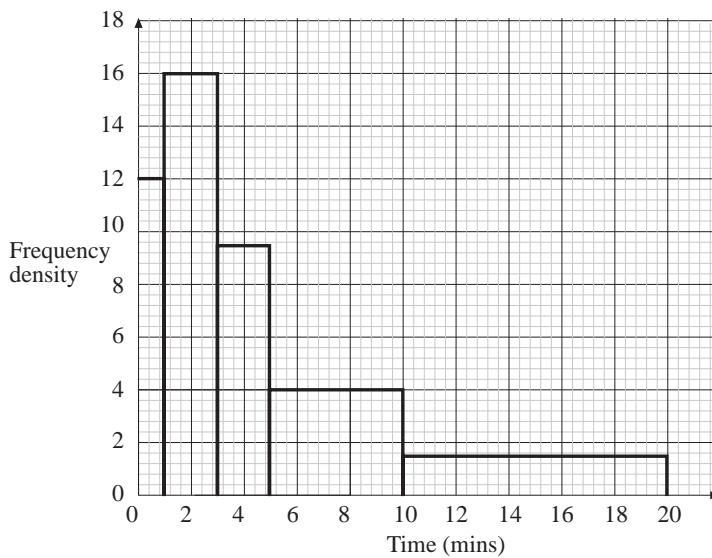

11. (a) Frequencies- 4, 6, 7, 4, 6, 1. (b) 28 matches.

8.8 Sampling

- (a) Possible answers: (i) C, F, I, L, O, R, U, X. (ii) D, H, L, P, T, X.
 (iii) F, L, R, X.

(c) Number 24 balls and place in a bag, then draw out the relevant number of balls to correspond with the number of machines.
- 13, 13, 14, 14, 13, 7, 6 (taking the integer part of each answer plus the two greatest remainders to give a sample of size 80)
- (a) 1, 2, 1, 13, 3. (b) 12
- (a) No (b) Change 5 to 6 and change 4 to 5.

5. (a) Working either across the rows or down the columns, choose the 10th square in each case.

9. (a) (i) 49, 36, 15.

(ii) This ensures that each age cohort has a fair representation.

(b)

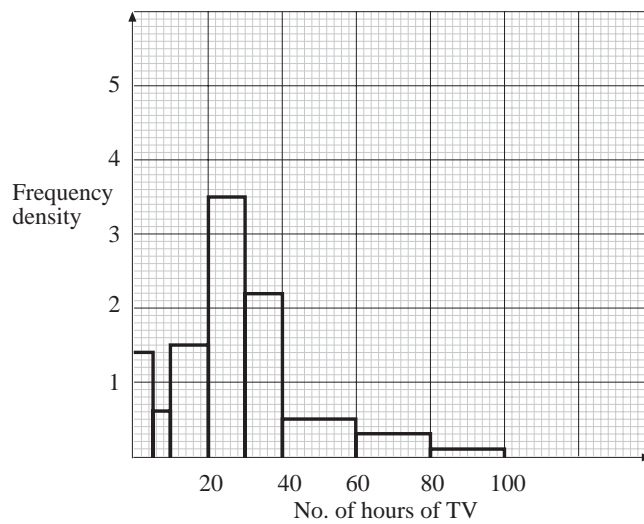

9 Data Analysis

9.1 Mean, Median, Mode and Range

1. (a) mean = 5 median = 4.5 mode = 3 range = 8
 (b) mean = 9.9 median = 9.5 mode = 7 range = 11
 (c) mean = 16.25 median = 16.5 mode = 17 range = 10
 (d) mean = 107.6 median = 108 mode = 108 range = 13
 (e) mean = 63 median = 64 mode = 61 range = 10
 (f) mean = 21.75 median = 21.5 mode = 16 range = 14
2. (a) 6.8 (b) 6.75 (c) 6 (d) $5\frac{1}{2}$
3. (a) (i) 4.875 (ii) 3.5 (iii) £3 (b) (i) mean (ii) mode
 (c) range = £13
4. (a) Fred: mean = 20.8, range = 2. Harry: mean = 24.2, range = 24.
 (b) Fred (c) Harry
5. (a) A: mean = 15.9, median = 20, mode = 20
 B: mean = 16.9, median = 17, mode = 17
 (b) Mode suggests A (c) Mean suggests B (d) Range: A = 15, B = 3.
6. (a) mean = 68, median = 68.5 (b) His mean increases to 68.4.
 (c) The median. It increases from 68.5 to 70, whereas the mean only increases by 0.4.
7. (a) He objects because the mode = 0 = median (b) mean = 2.30, range = 18
 (c) 15 fish
8. (a) 268.4 cars (b) The mean decreases.
9. (a) mean = 2.035, median = 2, mode = 2.
 (b) Either median or mode (whole numbers).
10. The mean will increase. 11. (a) 19°C (b) Archangel (c) 27°C
12. 225 grams 13. (a) mean = 2 (b) range = 4
14. (a) 77 kg (b) Hereward House, because they have a much heavier team.
15. (a) modal class = 24 pupils (b) mean class = 26 pupils
 (c) There is more of an even spread of pupils in Year 9.
16. (a) Pat: mean = 25.3, range = 18
 (b) They both have approximately the same mean, but Kim's scores are more consistent as shown by the smaller range; thus Kim should be selected.
17. (a) (i) 5.6 (ii) 0.5 (b) Leaving out the two extreme marks probably gives a less biased measure of performance.
 (c) Mean + Range = 5.2 + 0.6 = 5.8, therefore no mark could possibly exceed 5.8.

9.2 Finding the Mean using Tables and Tally Charts

1. mean = 1.25 2. mean = 1.93 3. mean = 4.08 4. mean = 3.56
5. (a) mean = 1.95 (b) 22 times 6. mean number = 1.15 trains
7. mean = 2.30 8.(a) 6 (b) 2.04
9. Missing frequencies are 1, 5, 0. Missing frequencies of tickets are 0, 20, 21, 10, 0.
mean = 2.8 (1 d.p.)

10. (a)

| <i>Weight Range (w)</i> | <i>Tally</i> | <i>Frequency</i> |
|-------------------------|-----------------|------------------|
| $30 \leq w < 40$ | | 4 |
| $40 \leq w < 50$ | | 7 |
| $50 \leq w < 60$ | | 7 |
| $60 \leq w < 70$ | | 8 |
| $70 \leq w < 80$ | | 1 |
| $80 \leq w < 90$ | | 3 |

(b) class $60 \leq w < 70$

11. (a) 3 (b) frequency = 21, total = 48, mean = 2.29.
(c) the number of children per family has decreased on average ($2.29 < 2.7$), and there is less variation from family to family (today's range is 3, whilst in 1960 it was 7).

9.3 Calculations with the Mean

1. mean = 161 55 2. mean = 2 3. mean = 4 4. mean = 60.15 kg
5. 7 6. 84% 7. £6000 8. 9.5 9. mean \approx 4.47 10. 320

9.4 Mean, Median and Mode for Grouped Data

1. (a) 33.09 (b) 33.42 (c) 30 - 39
2. (a) 40.90 (b) 41 (c) $40 \leq w < 45$
3. (a) Yes (b) 20.54 (c) 20.95 (d) Median is greater than the mean.
4. (a) No (b) median = 0.72, mean = 0.78. (c) The mean is the largest.
5. 11.45 years 6. (a) 11.95 (b) 10.92
7. (a) 9.65 (b) 9.92 (c) 11 - 15
8. (a) (i) 26.78 (ii) 27.17 (iii) 21 - 30
(b) (i) 21.5 (ii) 22.25 (iii) 21 - 30
(c) The second class have a lower mean but similar range.
9. (a) 0 - £1.00 (b) £1.44
10. (a) 21, 7, 2 (b) People would spend more time watching television than in summer.
(c) 23.83 (24 hours)

11. (a) 24 cm (b) 24.32 cm

12 (a)

| Temperature, T | Mid-point | Frequency |
|------------------|-----------|-----------|
| $40 < T \leq 50$ | 45 | 6 |
| $50 < T \leq 54$ | 52 | 6 |
| $54 < T \leq 58$ | 56 | 8 |
| $58 < T \leq 62$ | 60 | 5 |
| $62 < T \leq 70$ | 66 | 5 |

(b) $\frac{1660}{30} \approx 55.3$

(c)

| Interval | Freq. Density |
|----------|-----------------------|
| 40-50 | $\frac{6}{10} = 0.6$ |
| 50-54 | $\frac{6}{4} = 1.5$ |
| 54-58 | $\frac{8}{4} = 2$ |
| 58-62 | $\frac{5}{4} = 1.25$ |
| 62-70 | $\frac{5}{8} = 0.625$ |

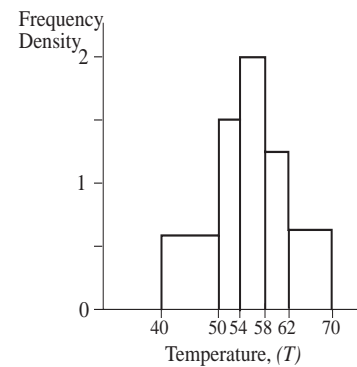

9.5 Cumulative Frequency

1. (a)

| Weight in grams (w) | Cumulative Frequency |
|-------------------------|----------------------|
| $60 < w \leq 80$ | 4 |
| $80 < w \leq 100$ | 32 |
| $100 < w \leq 120$ | 65 |
| $120 < w \leq 140$ | 92 |
| $140 < w \leq 160$ | 100 |

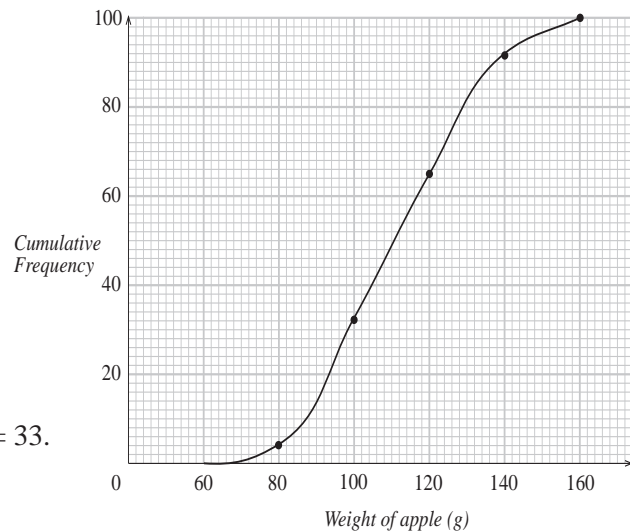

Median = 111, Inter-quartile range = 33.

(b)

| Distance in km (d) | Cumulative Frequency |
|------------------------|----------------------|
| $0 < d \leq 1$ | 5 |
| $1 < d \leq 2$ | 17 |
| $2 < d \leq 3$ | 22 |
| $3 < d \leq 4$ | 28 |
| $4 < d \leq 5$ | 33 |
| $5 < d \leq 6$ | 36 |

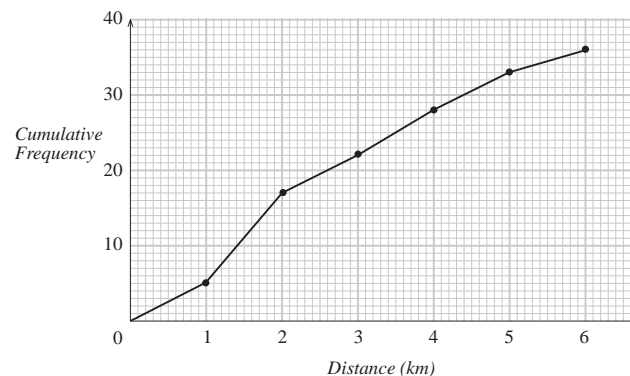

Median = 2.2, Inter-quartile range – any answer between 2 and 3 is acceptable.

(c)

| Length in metres (d) | Cumulative Frequency |
|--------------------------|----------------------|
| $1 < d \leq 2$ | 5 |
| $2 < d \leq 3$ | 17 |
| $3 < d \leq 4$ | 22 |
| $4 < d \leq 5$ | 28 |
| $5 < d \leq 6$ | 33 |

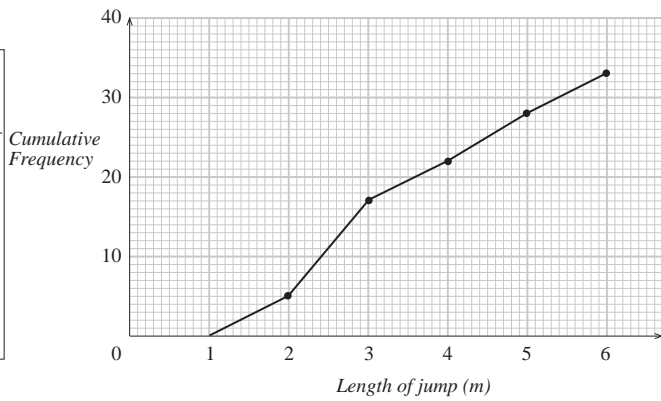

Median = 3, Inter-quartile range – any answer between 2 and 2.5 is acceptable.

2. (a)

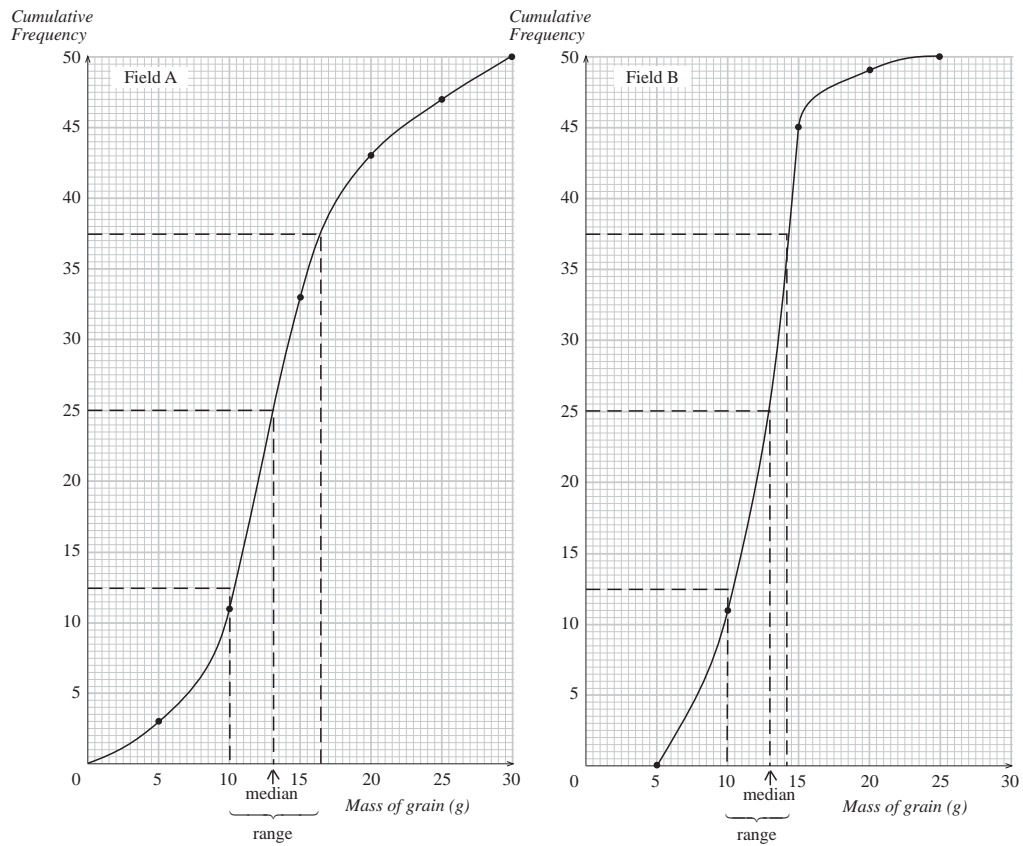

- (b) The median of field A is 13g, the median of field B is 12g.
The inter-quartile range for field A is around 7, for B it is around 4.
- (c) Field B is more reliable than field A (its inter-quartile range is narrower), although it is less productive in 50% of the cases (its median is lower than the median of field B).

3. (a) Cumulative Frequency

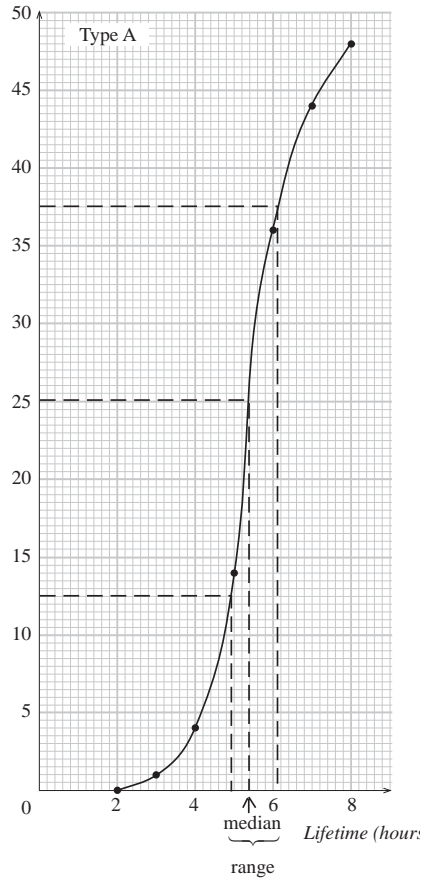

Cumulative Frequency

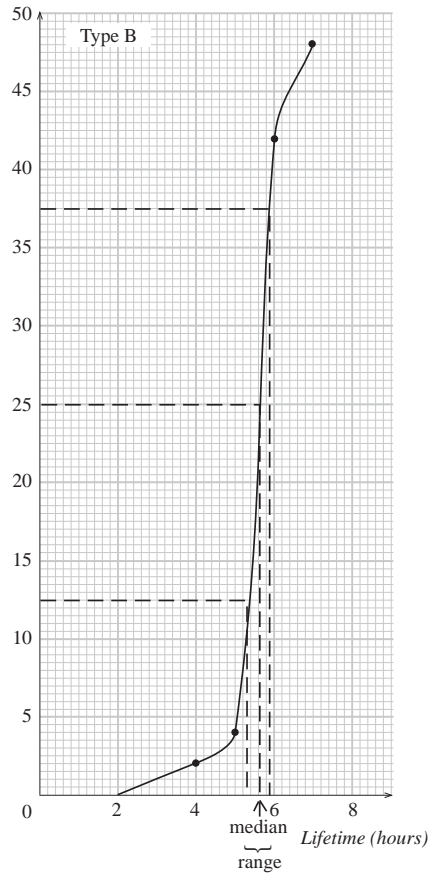

Median for type A = 5.6, Inter-quartile range for type A = 1.2.
 Median for type B = 5.8, Inter-quartile range for type B = 0.8.

(b) Type B - although both types have quite similar medians, type B is more predictable (its inter-quartile range is narrower) and most of the time its lifetime is above 5.

4. The heights of children in each category (to the nearest cm) are:

- Very tall - $75 < h \leq 85$
- Tall - $70 < h \leq 75$
- Normal - $62 < h \leq 70$
- Short - $58 < h \leq 62$
- Very short - $50 < h \leq 58$

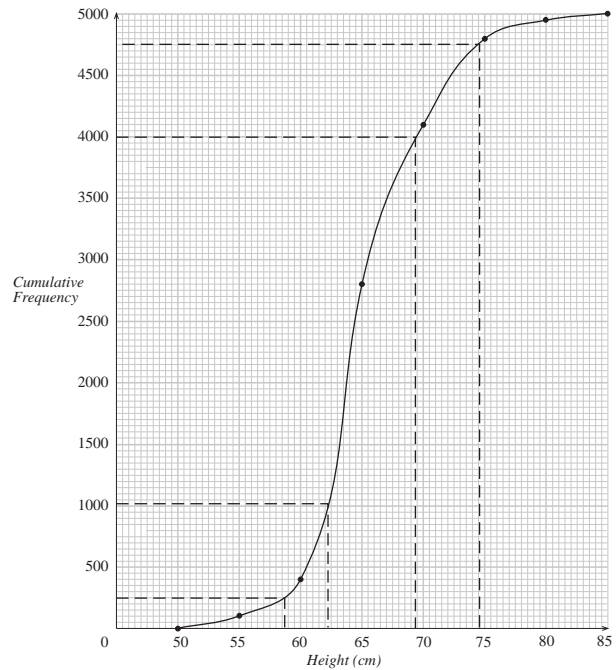

5.

Cumulative Frequency

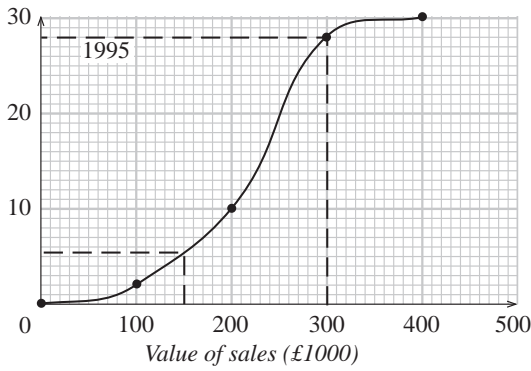

Cumulative Frequency

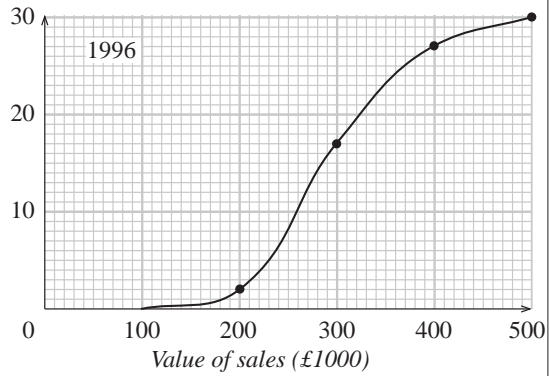

For 1995:

| Bonus | Value of sales |
|-------|--------------------|
| £50 | $300 < V \leq 400$ |
| £250 | $140 < V \leq 300$ |
| £500 | $0 < V \leq 140$ |

For 1996:

| Bonus | Value of sales |
|-------|--------------------|
| £50 | $100 < V \leq 230$ |
| £250 | $230 < V \leq 400$ |
| £500 | $400 < V \leq 500$ |

6. (a)

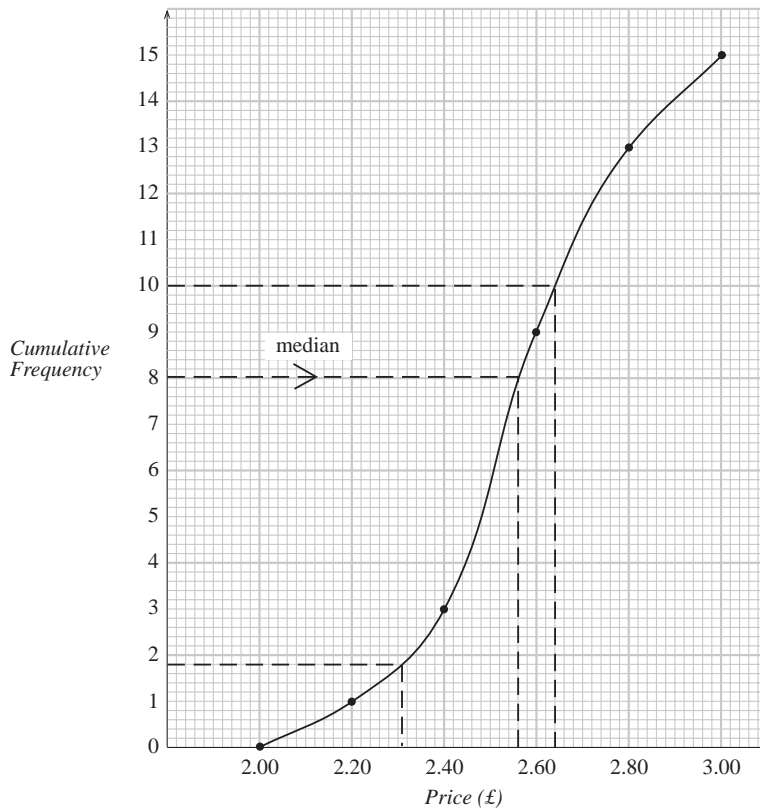

- (i) 5 or 6 shops
- (ii) About £2.50
- (iii) 2 shops
- (iv) 8 shops
- (v) 5 or 6 shops

(b) The only exact answer is (iv). The other answers are estimates since they relate to prices for which we do not have exact information.

7. (a)

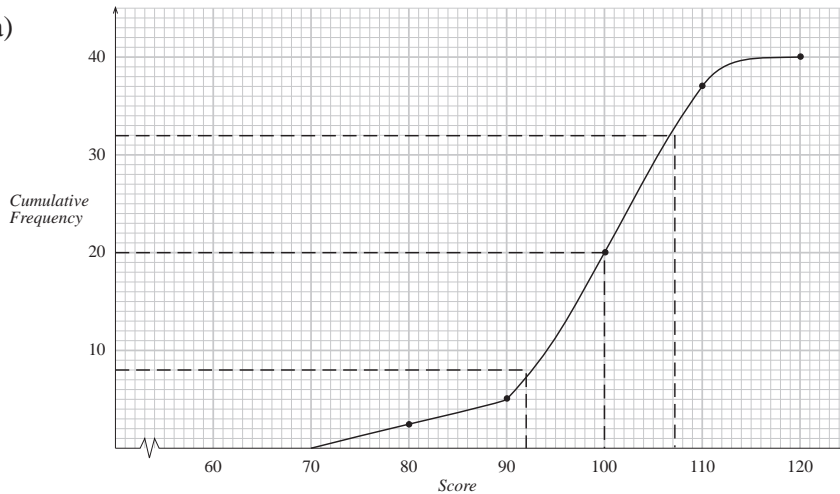

- (b) (i) Laura's median = 100 (ii) Inter-quartile range - between 14 and 16.
- (c) (i) Joy was the more consistent player because her inter-quartile range is lower.
- (ii) Laura won most of the games. She scored less than 100 in 20 matches and more than 103 in only 16 matches, whereas Joy scored more than 103 in 20 matches and her inter-quartile scores were quite consistent.

8. (a) Cumulative frequencies - 34, 56, 76, 80, 80.

(b)

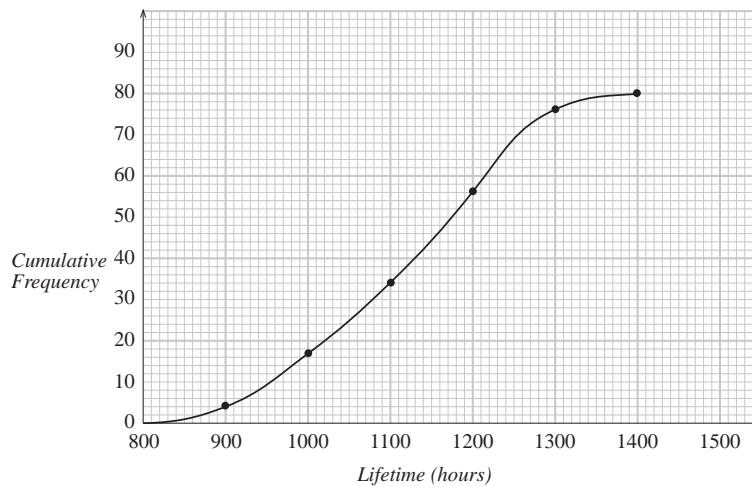

- (c) 58 bulbs (d) Inter-quartile range – between 250 and 260
- (e) The bulbs from the second sample are more reliable than those from the first.

9. (a) Cumulative frequencies 4, 11, 19, 25, 28, 32, 32.

- (b) (i) as graph.
- (ii) Median – between 25 and 28
- (iii) 6 people
- (c) The second group travelled more .

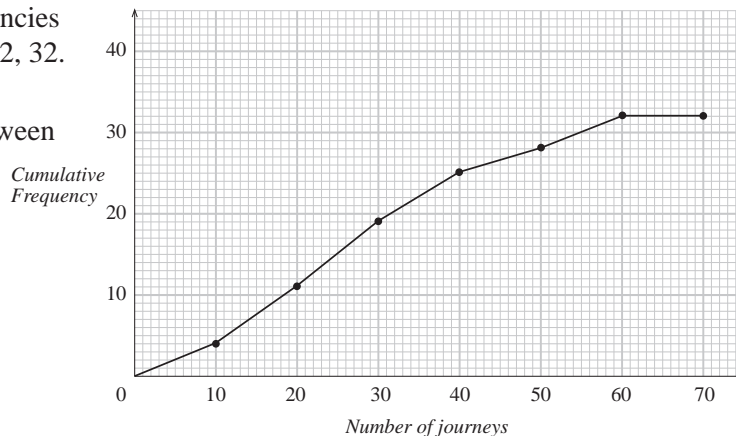

10. (a) Cumulative frequencies – 26%, 45%, 67%, 82%, 91%, 96%, 100%.

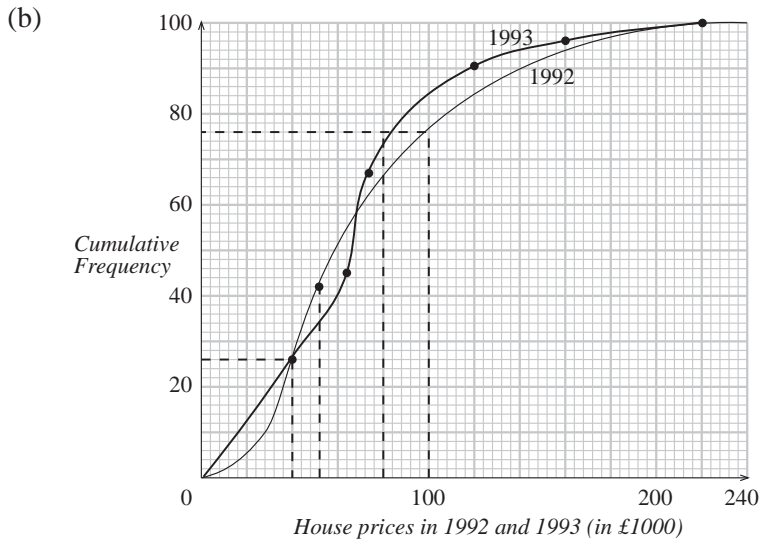

(c) In 1992, 76% of houses cost up to £100 000, whilst in 1993 76% of houses cost up to £80 000. Hence, in 1993 the price of the house should be around £80 000.

11. (a) Cumulative frequencies: 2, 6, 16, 40, 72, 89, 96, 100.

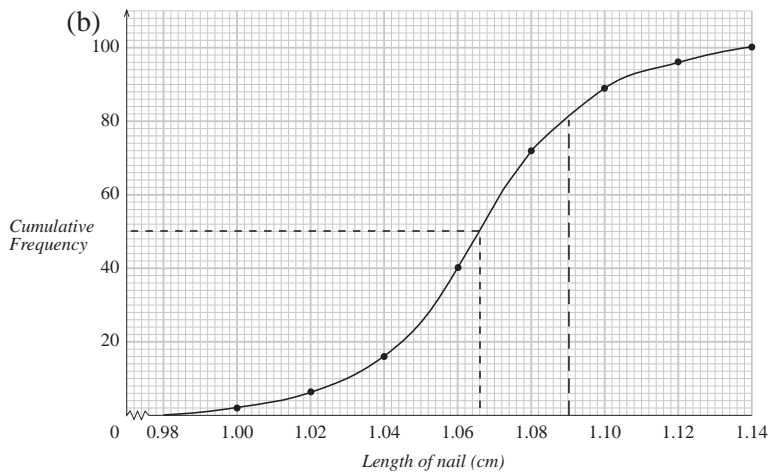

(i) Median: between 1.06 cm and 1.07 cm

(ii) Inter-quartile range : between 1.04 and 1.05

12. (a) Mean distance = 28.17 miles (to 2 d.p.)

(b) (i) Number of guests: 26, 64, 84, 104, 116.

(ii) as graph

(c) (i) Median: between 18 and 20 miles

(ii) The range is very large (140 miles), and 36 people (who make up almost a third) travel more than 30 miles (above the median). These upper values influenced the mean which is far above the median.

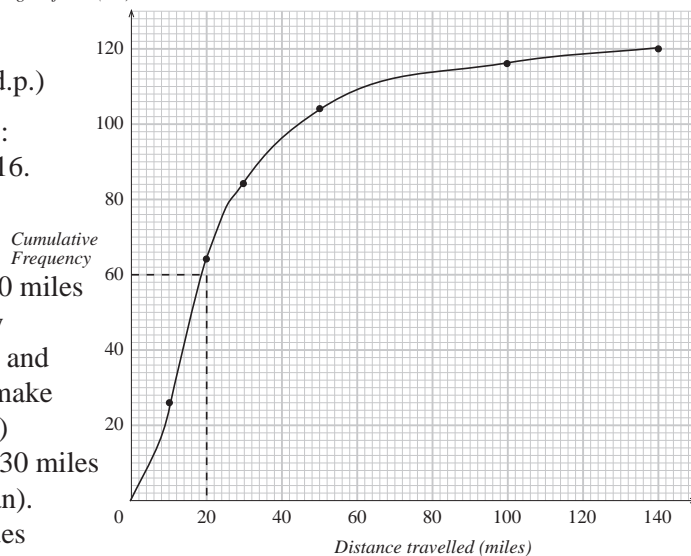

9.6 Standard Deviation

1. (a)

| | <i>Mean</i> | <i>Standard Deviation</i> |
|----------|-------------|---------------------------|
| <i>A</i> | 53.67 | 4.31 |
| <i>B</i> | 73.67 | 4.31 |
| <i>C</i> | 107.33 | 8.62 |

- (b) Adding same number to values: the mean increases but the s.d does not;
 × values by a scale factor: the mean increases and so does the s.d.

2. (a)

| | <i>Mean</i> | <i>Standard Deviation</i> |
|----------|-------------|---------------------------|
| <i>A</i> | 2.24 kg | 0.04 |
| <i>B</i> | 2.64 kg | 0.07 |

- (b) On average, the boxes filled by A weigh less than the boxes filled by B, but A is more accurate ($0.04 < 0.07$).

3.

| | <i>Mean</i> | <i>Standard Deviation</i> |
|----------|-------------|---------------------------|
| <i>A</i> | 10.02 | 0.43 |
| <i>B</i> | 9.6 | 0.14 |

The experiments done by B are more accurate and more reliable ($0.14 < 0.49$).

4. 45.61; 1.49 5. 6.7; 1.85

6. The estimated mean is 1.22, the estimated standard deviation is 0.96.

7. The estimated mean is 61.30, the estimated standard deviation is 51.61.

8.

| | <i>Estimated Mean</i> | <i>Estimated Standard Deviation</i> |
|----------|-----------------------|-------------------------------------|
| <i>A</i> | 1.57 | 1.15 |
| <i>B</i> | 3.2 | 1.99 |

On average, the sizes of the families in A are smaller and less spread out than in B.

9. (a) mean = 5, standard deviation = $\sqrt{2}$ ($\cong 1.41$)

- (b) Any five consecutive integers have the following pattern:

$$n - 2, n - 1, n, n + 1, n + 2, \text{ where } n \text{ is the middle integer.}$$

There are two integers which are 2 units away from n , ($n - 2$ and $n + 2$), and two integers which are 1 unit away from n , ($n - 1$ and $n + 1$). Since n is the mean, the standard deviation will be:

$$\sqrt{\frac{2^2 + 1^2 + 0^2 + 1^2 + 2^2}{5}} = \sqrt{\frac{10}{5}} = \sqrt{2}$$

10. (a) mean = 30, standard deviation = 16.11
(b) The means in both Mathematics and English are identical, but the marks in English are less spread out ($3.6 < 16.11$) than in Mathematics.
11. (a) (i) 32 (ii) 11.32
(b) On average, the girls performed less than boys ($30 < 32$), but their scores are less spread out ($6.5 < 11.32$) around the mean.
12. (a) 8.98
(b) Class A has, on average, higher and less spread out I.Q. scores than Class B.
(c) 0
13. (a) (i) 6 (ii) 2.16
(b) The second test has 6 as mean and 1.48 as standard deviation; e.g. the means are identical on both tests but the second group performed more homogeneously than the first group. On average, the scores of the second group were closer to 6 than the scores of the first group.
14. (a) mean = 4.5, s.d. = 1.86
(b) Yes it does. The values within one s.d. of the mean lie between 2.64 and 6.36. In our data these values are 3, 4, 5, 6. The total frequency of these values in our data is $7 + 8 + 9 + 10 = 34$. The percentage of values within one s.d. of the mean is therefore:

$$\frac{34}{50} \times 100 = 68\%.$$

10 Equations

10.1 Negative Numbers

- -4°C ; -2°C ; -8°C ; -14°C ; -8°C ; -5°C ; -7°C .
- (a) $-10, -6, -5, -4, 2, 3$ (b) $-4, -1, 0, 3, 7$
(c) $-6, -4, -2, 0, 3, 7$ (d) $-7, -4, -2, 0, 5, 7$
(e) $-5, -4, -3, -1, 0, 6$
- (a) $-7, -8, -9$ (b) $-3, -2, -1, 0, 1$ (c) $-2, -1$ (d) -2
(e) $-8, -7, -6, -5, -4, -3, -2, -1$
- (a) $-7, -8$ or -9 (b) $-7, -8, \dots$ (c) $-1, -2, -3$, or -4
(d) $-9, -8, \dots$ (e) -7 or -8 (f) $-5, -6, \dots$
- (a) $3 > 2$ (b) $-5 > -6$ (c) $0 > -1$ (d) $-7 > -10$ (e) $-2 > -4$
(f) $-1 > -6$ (g) $-5 < 0$ (h) $-9 < -6$ (i) $-8 < -2$

10.2 Arithmetic with Negative Numbers

- (a) 12 (b) -14 (c) -12 (d) -20 (e) -7 (f) -6
(g) -1 (h) 28 (i) 1 (j) 32 (k) -2 (l) 7
(m) -10 (n) 2 (o) -13 (p) -12 (q) 56 (r) 1
(s) -6 (t) -15 (u) -8 (v) -8 (w) 5 (x) -2

10.3 Simplifying Expressions

- (a) $6a$ (b) $3a + 12$ (c) $11a + 6b$ (d) $4x + 11y$
(e) $13x - y$ (f) $2a + 10b$ (g) $3a + b + 6$ (h) $6p - 7q$
(i) $-7x + 3y$ (j) $2x - p$ (k) $15x - 9z$ (l) $-14x + 5z$
(m) $8a + 4q - 6x$ (n) $-p - q + x + z$ (o) $3x - 2y + 10$ (p) $21x - 32q$
(q) $2y$ (r) $2x$ (s) $-19x + 11y$ (t) $23x - 18y - 4$
(u) $-7x - 10y$ (v) $-4p + 4q$
- (a) $6x^2 + 8x$ (b) $x^2 + 13x + 10$ (c) $2x^2 + 10x$
(d) $5x^2 + 2x + 10$ (e) $-x^2 + 7x$ (f) $3x^2 + 4y^2$
(g) $2x^2 + y^2 - x - y$ (h) $5x^2 - 3x - 10$ (i) $3x^2 - 3y^2 - x - y$
(j) $5x^2 + 2y - 4$ (k) $5ab + cd$ (l) $2xy + 5xz$
(m) $11ab - 3ad$ (n) $9pq - 3qr$
- (a) $3x + 15$ (b) $24 + 4x$ (c) $7x + 14$ (d) $2x + 12$
(e) $5x + 10$ (f) $8x + 12$ (g) $15x + 10$ (h) $40x + 24$
(i) $7x - 42$ (j) $40 - 8x$ (k) $8x - 28$ (l) $35x - 21$
(m) $18x - 30$ (n) $4x - 8y$ (o) $5x + 10y + 15z$ (p) $5x + x^2$

- (q) $2a - a^2$ (r) $4b - 12$ (s) $2x^2 - 12x$ (t) $8x^2 + 12x$
 (u) $21x - 6x^2$ (v) $8x^2 - 40x$
4. (a) $7a + 26$ (b) $7x + 23$ (c) $8x + 22$ (d) $2x^2 + 7x$
 (e) $x^2 + 9x + 4$ (f) $12a + 17b$

10.4 Simple Equations

1. (a) $x = 4$ (b) $x = 9$ (c) $x = 3$ (d) $x = 12$ (e) $x = 14$
 (f) $x = -2$ (g) $x = 9$ (h) $x = 4$ (i) $x = 18$ (j) $x = 8$
 (k) $x = 34$ (l) $x = 7$ (m) $x = 10$ (n) $x = 24$ (o) $x = 50$
 (p) $x = 12$ (q) $x = 21$ (r) $x = 66$ (s) $x = 8$ (t) $x = 6$
 (u) $x = 26$ (v) $x = 36$ (w) $x = 15$ (x) $x = 4$
2. (a) $x = -4$ (b) $x = -5$ (c) $x = 3$ (d) $x = -6$ (e) $x = -4$
 (f) $x = -14$ (g) $x = -6$ (h) $x = -3$ (i) $x = -12$ (j) $x = -16$
 (k) $x = -3$ (l) $x = -20$ (m) $x = 8$ (n) $x = 8$ (o) $x = 6$
 (p) $x = -5$ (q) $x = -10$ (r) $x = -26$
3. (a) $x + 110^\circ = 180^\circ$; $x = 70^\circ$ (b) $x + 92^\circ = 180^\circ$; $x = 88^\circ$
 (c) $x + 110^\circ = 180^\circ$; $x = 149^\circ$ (d) $42^\circ + x + 40^\circ = 180^\circ$; $x = 98^\circ$
4. $x - 2 = 16$; $x = 18$ 5. $12 \times x = 54$; $x = \text{£}4.50$ 6. $x + 3 = 41$; $x = \text{£}38$
7. 52 is double Majid's number, so the number is half of 52. It is 26.
 Alternatively, $x \times 2 = 52$, so $x = 26$.
8. 24 is double Jim's number, so his number is half of 24. It is 12.
 Alternatively, $x \times 2 = 24$, so $x = 12$.
9. Phillip is 11 years old. Sue is $11 - 2 = 9$ years old.
 Ali is twice as old as Sue, so Ali is $9 \times 2 = 18$ years old.

10.5 Solving Equations

1. (a) $x = 14$ (b) $x = 9$ (c) $x = 14$ (d) $x = 8$ (e) $x = 4$
 (f) $x = 1\frac{1}{3}$ (g) $x = -4$ (h) $x = -1$ (i) $x = \frac{-5}{3}$ (j) $x = 7$
 (k) $x = 6$ (l) $x = -2$ (m) $x = 10$ (n) $x = 1$ (o) $x = \frac{3}{5}$
 (p) $x = -2\frac{1}{2}$ (q) $x = \frac{1}{5}$ (r) $x = \frac{-3}{4}$ (s) $x = -3$ (t) $x = 0$
 (u) $x = \frac{-2}{5}$ (v) $x = 36$ (w) $x = 15$ (x) $x = 5$
2. (a) $x = -3$ (b) $x = -6$ (c) $x = \frac{13}{4}$ (d) $x = 14$

- (e) $x = 4$ (f) $x = 10$ (g) $x = 1$ (h) $x = -3$ (i) $x = 13$
 (j) $x = 3$ (k) $x = 4$ (l) $x = \frac{2}{3}$ (m) $x = 3$ (n) $x = 2$
 (o) $x = \frac{5}{3}$ (p) $x = 4$ (q) $x = 2$ (r) $x = \frac{1}{2}$ (s) $x = 8$
 (t) $x = 12$ (u) $x = 32$ (v) $x = 14$ (w) $x = 39$ (x) $x = 12$
3. (a) $(3x + 40) + 80 + x = 360$; $x = 60^\circ$
 (b) $(x + 10) + (x + 30) + (2x + 30) + x = 360$; $x = 58^\circ$
 (c) $(x + 10) + (x + 30) + (x - 10) = 360$; $x = 110^\circ$
 (d) $(140 - x) + (120 - x) + (180 - x) = 360^\circ$; $x = 26\frac{2}{3}^\circ$
4. $x + x + (x + 1) + (x + 1) = 10$; $x = 2$ m 5. $2x + 10 = 42$; $x = 16$
6. $6x - 8 = 34$; $x = 7$ 7. $4m + 2 = 6$; $m = 1$; Mary drives for 1 hour.
8. (a) $80 + (60 \times x) = 290$; $x = 3\frac{1}{2}$ (3 hours and 30 mins).
 (b) $80 + (60 \times x) = 220$; $x = 2\frac{1}{3}$ (2 hours and 20 mins).
9. (a) $(x + 6) \times 2 = 18$; $x = 3$ (b) $(x \div 2) + 10 = 16$; $x = 12$
 (c) $[(x \div 2) + 2] \times 2 = 9$; $x = 5$ (d) $[(x - 7) \div 2] \times 10 = 115$; $x = 30$
10. $x + (x + 1) + (x + 2) + (x + 3) = 114$; $x = 27$ 11. 6
12. (a) $y = 2x + 1$ (b) $x = 4$ 13. (a) 7 (b) 4 14. $x = 2$
15. (a) $x = 4\frac{1}{2}$ (b) $y = 4$
16. (a) $(3x + 1)$ cm (b) (i) $3x + 1 = 22$ (ii) 7 cm, 5 cm and 10 cm.
17. (a) $2x$ pence (b) $(x + 10)$ pence (c) 30 pence

10.6 Trial and Improvement Method

1. (a) $x = 5$ (b) $x = 27$ (c) $x = 5$ (d) $x = 12$ (e) $x = 3$
 (f) $x = 64$ (g) $x = 100$ (h) $x = 11$
2. (a) $x = 2.2$ (to 1 decimal place) (b) $x = 4.8$ (to 1 d.p.)
 (c) $x = 1.8$ (to 1 d.p.) (d) $x = 5.6$ (to 1 d.p.)
 (e) $x = 2.6$ (to 1 d.p.) (f) $x = 2.4$ (to 1 d.p.)
3. (a) $x = 1.82$ (to 2 d.p.) (b) 10.1 is a good starting number; $x = 10.07$ (2 d.p.)
 (c) 7.05 (to 2 d.p.)

4. (a) $x = 7$ or -8 (b) $x = 9$ or -8 (c) $x = 1$ or -1
 (d) $x = 10$ or -8 (e) $x = 7$ or -1 (f) $x = 3$ or -8
5. (a) $x = 1.14$ or 6.14 (b) $x = 5.24$ or 0.76 (c) $x = 2.32$ or -4.32
 (d) $x = 1.12$ or -7.12
6. (a) x cannot be negative because, so far, we have no meaning for the square root of a negative number.
 (b) $x = 5.628$ to 3 d.p.
7. (a) $x = 7.87$ or 0.13 (b) $x = 4.24$ or -0.24 (c) $x = 3.41$ or 0.59
 (d) $x = 23.31$ (e) $x = 6.46$ or 0.06 (f) $x = 6.19$ or 0.81
8. $x = 1.8$ to 1 d.p. 9. $x = 2.9$ gives the result nearest 11.
10. (a) $x = 5$
 (b) (i) $4^3 = 64$; $5^3 = 125$ (ii) $x = 4.6$ (to 1 d.p.) is the nearest value.
11. (a) 17.3 m (b) 1730 cm (to the nearest 10 centimetres)
12. (a) 2 and 3 (b) 2.7

10.7 Expanding Brackets

1. (a) $x^2 + x$ (b) $2x - 3x^2$ (c) $6a^2 - 27a$ (d) $x^2 - x^3$
 (e) $4x^2 - 28x$ (f) $3x + 11$ (g) $x^2 - 2x$ (h) $x + x^3$
 (i) $-4x^2 - 3$ (j) $-5x$ (k) $5x^2 - 20x$ (l) $5x^2 - 8$
 (m) $5x^2 - x^3$ (n) $3x + 16$ (o) $7x - 3x^2$
2. (a) $x^2 + 7x + 6$ (b) $x^2 + 11x + 28$ (c) $x^2 + 6x - 16$
 (d) $x^2 + 3x - 4$ (e) $x^2 - 8x + 7$ (f) $6x^2 + x - 1$
 (g) $8x^2 + 34x + 21$ (h) $10x^2 + 11x - 6$ (i) $24x^2 + 14x - 3$
 (j) $12x^2 - 13x + 3$ (k) $15x^2 - 58x + 48$ (l) $15a^2 - 29a - 14$
 (m) $12a^2 - 35a + 25$ (n) $24n^2 - 8n - 2$ (o) $20x^2 - 17x - 24$
3. (a) $x^2 + 2x + 1$ (b) $x^2 - 2x + 1$ (c) $x^2 + 16x + 64$
 (d) $4x^2 + 4x + 1$ (e) $9x^2 + 24x + 16$ (f) $36x^2 - 12x + 1$
 (g) $4x^2 - 20x + 25$ (h) $36x^2 - 84x + 49$ (i) $25x^2 + 90x + 81$
4. (a) $ac + ad + bc + bd$ (b) $2a^2 + 3ac + c^2$ (c) $3a^2 - 14ad - 5d^2$
 (d) $12x^2 + xy - y^2$ (e) $4a^2 + 13ad + 3d^2$ (f) $2a^2 + ab + 8ac + 4bc$
 (g) $9xy - y^2 - 18x^2$ (h) $q^2 - 2p^2 - pq$ (i) $45x^2 - xy - 2y^2$
 (j) $4x^2 + 4xy - 2x - 2y$ (k) $4a^2 - 2ac + 2ab - bc$
 (l) $4x^2 - 29xy + 30y^2$ (m) $p^2 - 4q^2$ (n) $5a^2 - 13ab - 6b^2$
 (o) $10x^2 - 27xy + 18y^2$

5. (a) $x^2 - 1$; $x^2 - 16$; $x^2 - 36$ (b) $x^2 - 25$ (c) $a^2 - b^2$
 (d) $(5x)^2 - 2^2 = 25x^2 - 4$
6. (a) $x^2 + x - 2$ (b) $2x^2 - 6x + 4$ (c) $2x^2 + 4x + 2$
7. (a) $x^3 - 3x^2 - 10x$ (b) $x^3 + 4x^2 - 4x - 16$
 (c) $x^3 + 2x^2 - 5x - 6$ (d) $6x^3 + 37x^2 - 39x - 28$
 (e) $x^3 + 3x^2 + 3x + 1$ (f) $x^3 - 12x^2 + 48x - 64$

10.8 Simultaneous Linear Equations

1. (a) $x = 1, y = 2$ (b) $x = 5, y = 2$ (c) $x = 10, y = 3$
 (d) $x = 4, y = 2$ (e) $x = \frac{46}{43}, y = \frac{-13}{43}$ (f) $x = 5, y = -2$
 (g) $x = -2, y = 12$ (h) $x = 10, y = 12$ (i) $x = 5, y = 6$
 (j) $x = \frac{5}{7}, y = \frac{9}{28}$ (k) $x = \frac{7}{45}, y = \frac{13}{36}$ (l) $x = 7, y = \frac{1}{5}$
 (m) $x = \frac{1}{2}, y = 3$ (n) $x = -3, y = -1$ (o) $x = \frac{43}{33}, y = \frac{48}{11}$
 (p) $x = 0.2, y = 0.4$ (q) $x = 6, y = 12$ (r) $x = 4, y = 18$

2. (a) (3, 5) (b) (3, 7) (c) $\left(\frac{20}{9}, \frac{16}{9}\right)$

3. It is not possible to eliminate either x or y because of their coefficients. If the equations had been used to produce graphs it would be seen that the two straight lines produced are parallel. Therefore, there can be no point of intersection and it is impossible to solve the equations simultaneously.

4. (b) There is no way of eliminating x or y in order to find the value of the other variable.

$$(c) \quad x + 2y = 12 \quad (1) \quad \text{gives} \quad y = 6 - \frac{x}{2}$$

$$3x + 6y = 36 \quad (2) \quad \text{gives} \quad y = 6 - \frac{x}{2}$$

So equations (1) and (2) are different versions of the same equation.

5. $v + c = 3.7$; $v - c = 1.3$; $v = 2.5, c = 1.2$.
6. 72 return tickets and 28 single tickets were sold.
7. (a) 79 ten-pound notes; 121 five-pound notes
 (b) 78 ten-pound notes; 122 five-pound notes
8. 16

9. The length of the flight is 9 hours; the time difference is 5 hours.

10. $x = -11, y = 15$ 11. $a = \frac{7}{2}, c = \frac{3}{2}$

12. (a) 2 metres

(b) (i) $t = 1$ when $h = 37$, so $37 = (a \times 1) + (b \times 1) + 2$ and $35 = a + b$

$t = 2$ when $h = 62$, so $62 = (a \times 4) + (b \times 2) + 2$ and $60 = 4a + 2b$

(ii) $a = -5; b = 40$

(c) 20.75 metres

10.9 Factorisation 1

1. (a) $5x + 10 = 5(x + 2)$ (b) $6x - 8 = 2(3x - 4)$
 (c) $15x + 25 = 5(3x + 5)$ (d) $12x + 8 = 4(3x + 2)$
 (e) $18 - 6x = 6(3 - x)$ (f) $6x - 21 = 3(2x - 7)$
 (g) $16a + 24 = 8(2a + 3)$ (h) $33x - 9 = 3(11x - 3)$

2. (a) $6(x + 4)$ (b) $5(x - 4)$ (c) $8(2 - x)$ (d) $4(2n + 3)$
 (e) $2(6x - 7)$ (f) $3(a - 8)$ (g) $11(x - 6)$ (h) $5(2 + 5x)$
 (i) $20(5x - 2)$ (j) $10(5 - 4x)$ (k) $6(x - 5)$ (l) $5(y - 9)$
 (m) $12(1 + 3x)$ (n) $16(x + 2)$ (o) $3(9x - 11)$

3. (a) $x(x + 1)$ (b) $x(x + 2)$ (c) $a(2a - 5)$ (d) $x(4x + 1)$
 (e) $x(x + 4)$ (f) $x(a + b)$ (g) $3x(2x + 1)$ (h) $2x(2x - a)$

4. (a) $x(5x + 1)$ (b) $a(a + 3)$ (c) $n(5n + 2)$ (d) $3n(2n + 1)$
 (e) $5n(n - 2)$ (f) $3x(x + 2)$ (g) $15x(x + 2)$ (h) $7x(2x + 3)$
 (i) $8x(2x + 3)$ (j) $6x(5x - 3)$ (k) $5(1 + n^2)$ (l) $5(2n^2 - 3)$
 (m) $3n(n^2 + 3)$ (n) $9x(x + 3)$ (o) $5x^2(2x - 1)$

5. (a) $ax(1 + x)$ (b) $x(b + cx)$ (c) $2q(p - 2r)$ (d) $5y(3x - y)$
 (e) $8p(2q + 3p)$ (f) $6x(x + 3y)$ (g) $3p(p - 3x)$
 (h) $8x(3p + 7x)$ (i) $2xy(8x - 9y)$

6. (a) Yes; $2x(3x + 1)$ (b) Yes; $8x^2(2x + 1)$ (c) No
 (d) Yes; $3xy(x - 6y)$

10.10 Factorisation 2

1. (a) $(x + 2)^2$ (b) $(x + 4)(x + 3)$ (c) $(x + 4)(x + 2)$
 (d) $(x + 6)(x + 1)$ (e) $(x + 8)(x + 2)$ (f) $(x + 3)(x + 1)$
 (g) $(x + 5)(x + 3)$ (h) $(x + 2)(x + 1)$ (i) $(x + 4)(x + 1)$
 (j) $(x + 3)(x + 8)$ (k) $(x + 11)(x + 1)$ (l) $(x + 8)(x + 7)$
 (m) $(x + 3)(x + 3)$ (n) $(x + 5)(x + 2)$ (o) $(x + 7)(x + 2)$
 (p) $(x + 6)(x + 5)$ (q) $(x + 8)(x + 1)$ (r) $(x + 8)(x + 4)$
2. (a) $(x + 2)(x - 1)$ (b) $(x - 4)(x + 3)$ (c) $(x - 5)(x + 2)$
 (d) $(x + 5)(x - 1)$ (e) $(x - 7)(x + 2)$ (f) $(x - 4)(x + 2)$
 (g) $(x + 5)(x - 3)$ (h) $(x - 2)(x - 1)$ (i) $(x - 5)(x - 4)$
 (j) $(x - 7)(x - 3)$ (k) $(x - 7)(x - 2)$ (l) $(x - 5)(x - 2)$
 (m) $(x - 8)(x + 2)$ (n) $(x - 9)(x - 8)$ (o) $(x - 8)(x + 3)$
3. (a) $(x + 1)(x - 1)$ (b) $(x + 4)(x - 4)$ (c) $(x + 9)(x - 9)$
 (d) $(3x + 2)(3x - 2)$ (e) $(4x + 6)(4x - 6)$ (f) $(2x + 10)(2x - 10)$
 (g) $(x^2 + 10)(x^2 - 10) = (x^2 + 10)(x + \sqrt{10})(x - \sqrt{10})$
 (h) $(x^2 + 2)(x^2 - 2) = (x^2 + 2)(x + \sqrt{2})(x - \sqrt{2})$
 (i) $(2x^2 + 3)(2x^2 - 3) = (2x^2 + 3)(\sqrt{2}x + \sqrt{2})(\sqrt{2}x - \sqrt{2})$
4. (a) $(2x + 1)(x + 1)$ (b) $(3x + 1)(x + 2)$ (c) $(2x + 3)(x + 1)$
 (d) $(3x + 2)(x + 4)$ (e) $(2x - 1)(x + 5)$ (f) $(4x + 3)(x - 2)$
 (g) $(3x - 5)(x + 2)$ (h) $(3x - 2)(x - 7)$ (i) $(3x + 1)(2x + 5)$
 (j) $(4x - 1)(2x - 1)$
5. (a) $(3x + 1)(x - 1)$ (b) $(3x + 1)(x + 1)$ (c) $(2x + 1)(x + 2)$
 (d) $(3x + 2)(x + 2)$ (e) $(3x - 1)(x + 3)$ (f) $(4x + 1)(x - 3)$
 (g) $(5x - 2)(x + 1)$ (h) $(3x - 2)(x - 2)$ (i) $(5x - 2)(x + 3)$
 (j) $(3x + 1)(2x + 1)$ (k) $(2x - 1)(3x - 2)$ (l) $(5x + 1)(2x - 1)$
 (m) $(4x - 1)(2x + 3)$ (n) $(2x + 7)(3x - 1)$ (o) $(3x - 4)(2x - 3)$
6. (a) $2x^2 + 9x + 4$ (b) $2x(2x - 3)$
7. (a) $3pq(4p - 5q)$ (b) $2x^2 + 7x - 15$ (c) $n = (C - 120) \div 40$

10.11 Solving Quadratic Equations by Factorisation

1. (a) $x = -4$ or 3 (b) $x = 5$ or -3 (c) $x = -6$ or 2 (d) $x = 6$ or 0
 (e) $x = 0$ or $\frac{4}{3}$ (f) $x = 0$ or $\frac{9}{4}$ (g) $x = 3$ or -3 (h) $x = 7$ or -7
 (i) $x = \frac{8}{3}$ or $-\frac{8}{3}$ (j) $x = 4$ (both answers) (k) $x = -5$ (both answers)
 (l) $x = 6$ or -3 (m) $x = 4$ or 7 (n) $x = 6$ or -5 (o) $x = 10$ or 4
 (p) $x = -3$ or $-\frac{1}{2}$ (q) $x = \frac{3}{2}$ or -4 (r) $x = 1$ or $\frac{4}{3}$
 (s) $x = \frac{3}{4}$ or -1 (t) $x = \frac{1}{2}$ or -3 (u) $x = 7$ or $\frac{5}{2}$

2. (a)

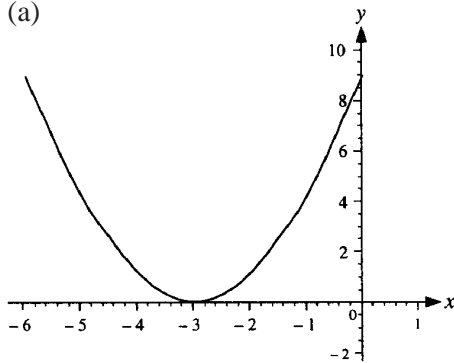

The curve touches the x -axis at the point where $x = -3$.

(b)

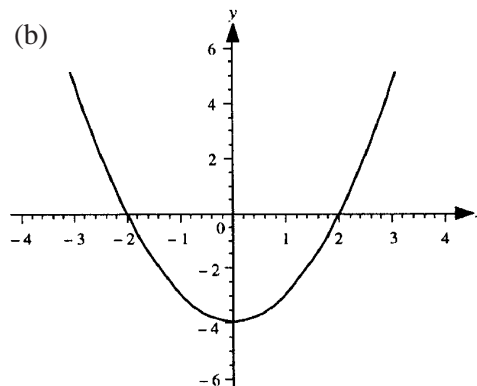

The curve cuts the x -axis at the points where $x = 2$ and $x = -2$.

(c)

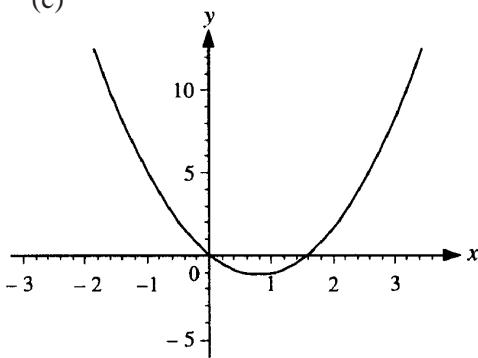

The curve cuts the x -axis at the points where $x = 0$ and $x = \frac{3}{2}$.

(d)

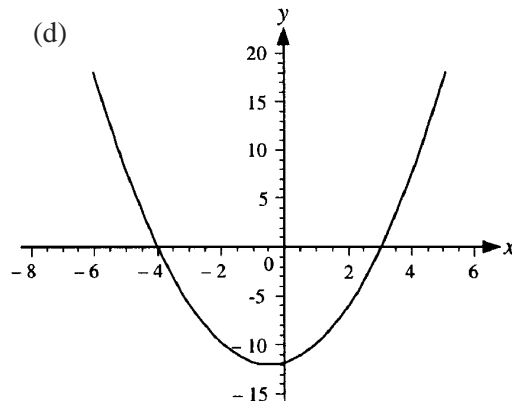

The curve cuts the x -axis at the points where $x = 3$ and $x = -4$.

3. (a) $(x^2 + 4)(x + 2)(x - 2) = 0$, so $x = -2$ or 2
 (b) $(x^2 + 25)(x + 5)(x - 5) = 0$, so $x = -5$ or 5
 (c) $(x^3 + 1)(x^3 - 1) = 0$, $(x^3 + 1)(x - 1)(x^2 + x + 1) = 0$,
 $(x + 1)(x^2 - x + 1)(x - 1)(x^2 + x - 1) = 0$, so $x = -1$ or 1

4. (a) $x = 5$ (b) $x = 4$ (c) $x = 4$ (d) $x = 8$
5. $t = 0.8$ 6. (a) $L = \frac{2V}{W(E + R)}$ (c) $L = 5$ or $L = 10$

10.12 Solving Quadratic Equations using the Formula

1. (a) 1 or 0.75 (b) 2 or -2.5 (c) 1.49 or -0.82 (2 d.p.)
 (d) 2.57 or -0.91 (2d.p.) (e) 2.37 or -3.37 (2 d.p.)
 (f) 2.43 or 0.93 (g) 0.5 or -9 (h) 14 or 0
 (i) 2.32 or -4.32 (2 d.p.) (j) 0.12 or 2.79
 (k) $\sqrt{-6}$ is involved so we can give no answers. (l) 3.58 or 0.42
 (m) 1.69 or -0.44 (2 d.p.)
 (n) $\sqrt{-224}$ is involved so we can give no answers. (o) 6.74 or -0.74
2. (a) Area = $x(x + 2)$
 (b) The ticket is 2.32 cm wide and 4.32 cm long, both measures correct to 2 d.p.
3. The height is 1.69 m and the width is 1.19 m.
4. (a) The stone hits the ground after 2.04 seconds (correct to 2 d.p.)
 (b) 1.46 seconds, correct to 2 d.p.
 (c) The stone never reaches a height of 12 m above the ground level.
 (d) $m = 20t - 9.8t^2$. The maximum height is 10.20 m, correct to 2 d.p.
5. (a) The maximum stretch is 16.18 metres.
 (b) The rope would stretch by 18.11 metres, an increase of 1.93 m.
6. $x = 6.14$ or -1.14 , both answers correct to 3 s.f.

10.13 Algebraic Fractions

1. (a) x^2 (b) $\frac{x+2}{x(x-2)}$ (c) $\frac{x-3}{x-2}$ (d) $\frac{2x-1}{x(x+1)}$
 (e) $\frac{x^2(x-6)}{x+6}$ (f) $\frac{1}{x}$ (g) $\frac{5x-3}{x}$ (h) $\frac{2x+1}{x}$ (i) $\frac{x-3}{x+2}$
2. (a) $\frac{1}{x}$ (b) x (c) $2x$ (d) $\frac{x^2+5x}{x+5}$ (e) $x(x-1)$
 (f) $x^2(x^2+x+1)$ (g) $\frac{x}{x-1}$ (h) $\frac{x(x+2)(x-2)}{(x-4)(x+1)}$ (i) $\frac{x-3}{x+1}$
 (j) $\frac{x(x+4)}{x-2}$ (k) $\frac{x+5}{x-3}$ (l) $\frac{x(x-2)}{x+1}$ (m) $\frac{(x-1)}{x(x-3)}$

- (n) $\frac{x(x-1)}{x+8}$ (o) $\frac{x-5}{x(x+6)}$ (p) $\frac{5x-6}{x+1}$ (q) $\frac{5x-2}{x-7}$
- (r) $\frac{3x+1}{5x+1}$ (s) $\frac{2x-7}{3x+2}$ (t) $\frac{4x-3}{5x-1}$ (u) $\frac{x(3x+2)}{4x+3}$
3. (a) $\frac{x}{x+4}$ (b) $\frac{x-1}{x(x+1)}$ (c) $\frac{(x+2)^2}{x}$ (d) $\frac{3}{x^2(x+2)}$
- (e) $\frac{(x+3)^2}{x^3}$ (f) $x(x+3)$ (g) $\frac{x^2(x-1)}{x+1}$ (h) $\frac{x^3(x+1)}{(x+4)^2}$
- (i) $\left(\frac{x+3}{x-4}\right)^2$
4. (a) $\frac{3x-1}{(x+2)(x-5)}$ (b) $\frac{-x-14}{(x+2)(x-1)}$ (c) $\frac{x}{(x+1)(x-1)}$
- (d) $\frac{8}{x+2}$ (e) $\frac{x+4}{(x+3)(x-3)}$ (f) $\frac{3(3x-13)}{(x-3)(x-6)}$
- (g) $\frac{2x(x-1)}{(x-4)(x+2)}$ (h) x (i) $\frac{2x^2+3x-24}{(x-6)(2x-1)}$ (j) $\frac{x(5x-14)}{(x+2)(x-6)}$
- (k) $\frac{x(2x-1)}{(x-1)(x+1)}$ (l) $\frac{x^2+8x+1}{x^2}$ (m) $\frac{x(5x+33)}{(x+6)(x+7)}$
- (n) $\frac{2x^2+11x+11}{(x+2)(x+3)}$ (o) $\frac{2x^2-7x-17}{(x+1)(x+2)}$

10.14 Completing the Square

1. (a) $(x+2)^2 - 9$ (b) $(x+3)^2 - 10$ (c) $(x+5)^2 - 27$
- (d) $(x-4)^2 - 14$ (e) $(x+6)^2 - 33$ (f) $(x-10)^2 - 90$
- (g) $\left(x + \frac{3}{2}\right)^2 - \frac{13}{4}$ (h) $\left(x - \frac{5}{2}\right)^2 - \frac{17}{4}$ (i) $\left(x - \frac{1}{2}\right)^2 + \frac{15}{4}$
2. (a) -1 and -3 (b) $3 + \sqrt{13}$ and $3 - \sqrt{13}$ (c) $-5 + \sqrt{33}$ and $-5 - \sqrt{33}$
- (d) $\frac{-5}{2} + \frac{\sqrt{21}}{2}$ and $\frac{-5}{2} - \frac{\sqrt{21}}{2}$ (e) $-\frac{1}{2} + \frac{\sqrt{5}}{2}$ and $-\frac{1}{2} - \frac{\sqrt{5}}{2}$
- (f) $-1 + \sqrt{5}$ and $-1 - \sqrt{5}$ (g) $-2 + \sqrt{12}$ and $-2 - \sqrt{12}$
- (h) $-\frac{5}{2} + \frac{\sqrt{33}}{2}$ and $-\frac{5}{2} - \frac{\sqrt{33}}{2}$ (i) $-\frac{7}{2} + \frac{\sqrt{45}}{2}$ and $-\frac{7}{2} - \frac{\sqrt{45}}{2}$
3. (a) $2(x+2)^2 - 3^2$ (b) $2\left(x + \frac{5}{2}\right)^2 - \frac{31}{2}$ (c) $2\left(x + \frac{1}{2}\right)^2 + \frac{1}{2}$

- (d) $3(x + 1)^2 - 5$ (e) $5\left(x + \frac{3}{2}\right)^2 - \frac{61}{4}$ (f) $7(x - 1)^2 - 5$
 (g) $3(x + 2)^2 - 16$ (h) $4\left(x + \frac{5}{2}\right)^2 - 28$ (i) $2(x - 3)^2 - 15$

4. (a) $x = -1 \pm \sqrt{\frac{7}{2}}$ (b) $x = -4 \pm \sqrt{\frac{35}{2}}$ (c) $x = -2 \pm \sqrt{\frac{20}{3}}$
 (d) $x = -\frac{1}{2} \pm \sqrt{\frac{1}{2}}$ (e) $x = \frac{13}{4}$ and $\frac{-15}{4}$ (f) $x = 2 \pm \sqrt{\frac{19}{5}}$

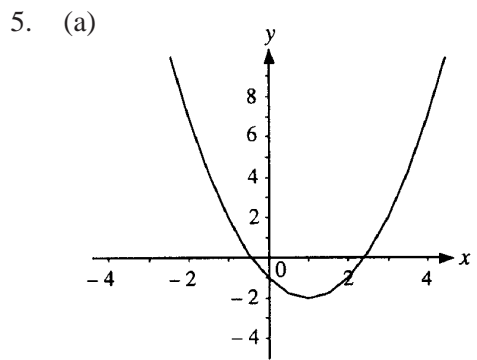

$y = 0$ when $x = -0.41$ and 2.41 ;
 the minimum value of y is -2 .

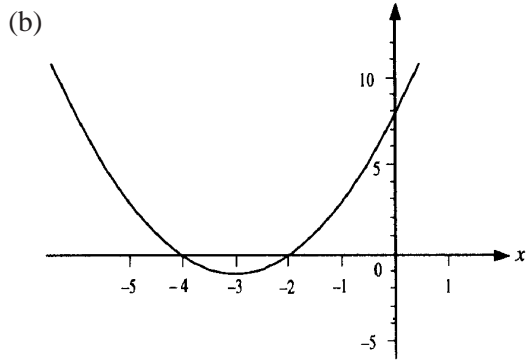

$y = 0$ when $x = -2$ and -4 ;
 the minimum value of y is -1 .

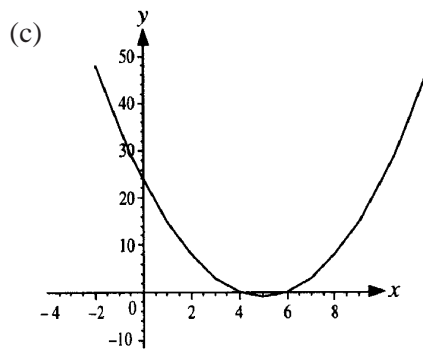

$y = 0$ when $x = 4$ and 6 ;
 the minimum value of y is -1 .

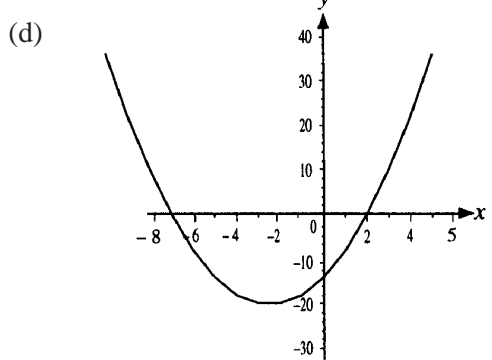

$y = 0$ when $x = 2$ and 7 ;
 the minimum value of y is -20.25

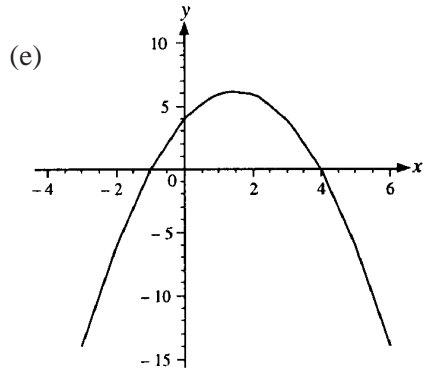

$y = 0$ when $x = 4$ and -1 ;
 the minimum value of y is 6.25 .

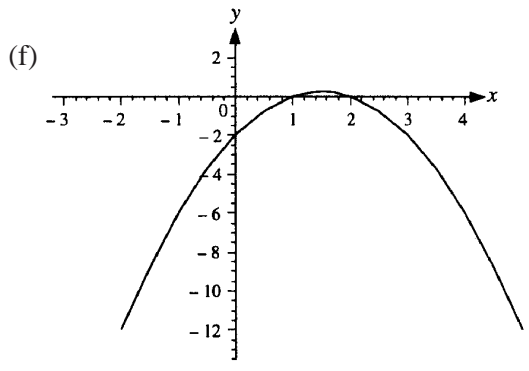

$y = 0$ when $x = 1$ and 2 ;
 the minimum value of y is 0.25 .

6. The maximum height of the ball is 11.
7. (a) $a = -2$, $b = -2$; the minimum value is -2 .
 (b) $x = 3.41$ and $x = 0.59$
8. (a) $(x + 3)(x - 1)$ (b) $(x + 1)^2 - 4$ (c)

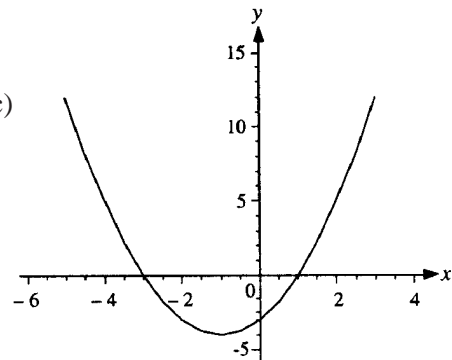

10.15 Algebraic Fractions and Quadratic Equations

- | | | |
|-----------------------------------|--------------------------|------------------------------------|
| 1. Both answers are 4 | 2. 4 and -1 | 3. 5 and 15 |
| 4. 2 and $\frac{-2}{3}$ | 5. 3 and -5 | 6. 7 and $\frac{1}{4}$ |
| 7. 2 and $\frac{-23}{9}$ | 8. 10 and $\frac{-5}{2}$ | 9. 3 and $\frac{1}{3}$ |
| 10. 2 and $\frac{-48}{7}$ | 11. 8 and $\frac{5}{2}$ | 12. 1 and $\frac{9}{4}$ |
| 13. $\frac{-9 \pm \sqrt{113}}{8}$ | 14. 3 and $\frac{44}{3}$ | 15. $\frac{35 \pm \sqrt{845}}{10}$ |

11 Fractions and Percentages

11.1 Fractions, Decimals and Percentages

1. (a) $\frac{1}{10}$ (b) $\frac{4}{5}$ (c) $\frac{9}{10}$ (d) $\frac{1}{20}$ (e) $\frac{1}{4}$ (f) $\frac{3}{4}$
 (g) $\frac{7}{20}$ (h) $\frac{19}{50}$ (i) $\frac{1}{25}$ (j) $\frac{3}{25}$ (k) $\frac{41}{50}$ (l) $\frac{37}{50}$
2. (a) 0.32 (b) 0.5 (c) 0.34 (d) 0.2 (e) 0.15 (f) 0.81
 (g) 0.04 (h) 0.03 (i) 0.07 (j) 0.18 (k) 0.75 (l) 0.73
3. (a) 50% (b) 74% (c) 35% (d) 8% (e) 10% (f) 52%
 (g) 80% (h) 7% (i) 4% (j) 18% (k) 40% (l) 30%
4. (a) 50% (b) 70% (c) 20% (d) 75% (e) 10% (f) 90%
 (g) 80% (h) 8% (i) 32% (j) 35% (k) 28% (l) $66\frac{2}{3}\%$
5. (a) $\frac{2}{3} = \frac{10}{15} = \frac{16}{24}$ (b) 35% 6. (a) correct drawing (b) 75%
7. (a) 180 m^2 (to the nearest square metre) (b) (i) 120 m^2 (ii) 20 %

11.2 Simple Fractions and Percentages of Quantities

1. (a) 20 (b) £2.50 (c) £1.60 (d) £25 (e) £200
 (f) 180 (g) £4 (h) 600 (i) 750 (j) 16 kg
 (k) 3.5 kg (l) 15 kg (m) 5 m (n) 10 m (o) £7.50
2. (a) 32 (b) 90 (c) 18 (d) 90 (e) 120 (f) 150
3. (a) 400 g (or 0.4 kg) (b) 240 g (or 0.24 kg) 4. £3 000
5. £25 6. £150 7. £60 8. 360 m 9. £1.50
10. 9 kg 11. 80 p 12. 2.4 kg (or 240 g)
13. (a) £5.60 (b) £5 (c) 2.25 metres
14. (a) £90 (b) $\frac{1}{6}, \frac{2}{9}, \frac{1}{3}, \frac{5}{6}$ 15. 170 grams
16. 1400 headphones
17. No.
 $\frac{2}{5}$ of the price is equivalent to 40% of the price, therefore 30% of the price is not enough to pay the deposit.

11.3 Quantities as Percentages

- (a) 16% (b) 12% (c) 40% (d) 30% (e) 12%
 (f) 15% (g) 15% (h) 30% (i) 90% (j) 40%
 (k) 42% (l) 65% (m) 40% (n) 30% (o) 85%
- 40% of the class are girls and 60% are boys. 3. 20% 4. 8%
- 56% *Manchester United* supporters and 44% *Tottenham* supporters.
6. 20% 7. 60% 8. 81% 9. 92% 10. $33\frac{1}{3}\%$
11. 4% 12. 80% 13. 45%
14. (a) $\frac{3}{18} = \frac{1}{6}$ (b) 12 pieces (c) $33\frac{1}{3}\%$

11.4 More Complex Percentages

- (a) £16 (b) £12.45 (c) £5.04 (d) £1.41 (e) £3.59
 (f) 69 p (g) £32 (h) £194.75 (i) 28 p
 - (a) £487.63 (b) £1184.74 (c) £15 240 (d) £205.37
 (e) £390.60 (f) £204 (g) £9359.22
 - (a) £132 (b) £153.75 4. 24 400 ice-creams 5. £1375
 6. £147 7. 202.5 grams 8. £227.29 9. £94.50 10. £76
 11. £61.25 12. (a) £41.40 (b) (i) £69 (ii) 945 (iii) £295.80
- $$\begin{array}{r} 24 \times \\ \hline 18900 \\ 3780 \\ \hline 22680 \end{array}$$
- (a) (i) £52.15 (ii) £350.15
 (b) (i) £7.50 (£360 – £352 50) (ii) *Berries' Store*

11.5 Percentage Increase and Decrease

- 21.4% 2. 25% 3. 13.1% 4. 18.9%
5. Karen has a 23.5% saving and John has a 12.7% saving. 6. 40%
7. There is a 10.3% increase in the number of pupils and a 2.7% increase in the number of teachers. Therefore, class sizes will increase because the number of teachers has not increased at the same rate as the number of pupils.
8. 25% 9. 22.9%
10. 4.3% increase, therefore estimated value after another year is £50 086.96. (£50 100)

11. 4.2%

12. Percentage decrease in the value of the car is greatest during the first year. (16.7%)

13. (a) £7 (b) (i) £6.49 (ii) It would be £1.99 cheaper. (c) 21.5%

14. (a) £80 (b) 15% 15. 12.5%

11.6 Addition and Subtraction of Fractions

1. (a) $\frac{2}{5}$ (b) $\frac{1}{2}$ (c) $\frac{6}{7}$ (d) $\frac{3}{7}$ (e) $\frac{3}{13}$ (f) $\frac{1}{3}$
 (g) $\frac{5}{3}$ (h) $\frac{7}{5}$ (i) $\frac{11}{7}$ (j) $\frac{2}{5}$ (k) $\frac{1}{3}$ (l) $\frac{1}{5}$

2. (a) 14, 29 (b) 6, 5, 11 (c) 2, 3 (d) 3, 4, 7 (e) 12, 14, 26
 (f) 36, 35, 71

3. (a) $\frac{13}{24}$ (b) $\frac{39}{35}$ (c) $\frac{7}{32}$ (d) $\frac{13}{30}$ (e) $\frac{59}{56}$ (f) $\frac{7}{6}$
 (g) $\frac{17}{70}$ (h) $\frac{47}{24}$ (i) $\frac{32}{21}$ (j) $\frac{1}{14}$ (k) $\frac{13}{44}$ (l) $\frac{1}{2}$
 (m) $\frac{1}{12}$ (n) $\frac{5}{24}$ (o) $\frac{13}{24}$

4. $\frac{11}{15}$ hectare 5. £1 $\frac{5}{12}$ million 6. $\frac{1}{10}$ cm 7. $\frac{13}{30}$ 8. $\frac{3}{20}$

9. $\frac{1}{6}$ 10. $2\frac{7}{12}$ kg

11.7 Multiplication and Division of Fractions

1. (a) $\frac{15}{28}$ (b) $\frac{7}{40}$ (c) $\frac{1}{15}$ (d) $\frac{27}{70}$ (e) $\frac{5}{14}$ (f) $\frac{9}{14}$
 (g) $\frac{3}{28}$ (h) $\frac{2}{21}$ (i) $\frac{2}{3}$ (j) 2 (k) $10\frac{5}{12}$ (l) $3\frac{3}{4}$
 (m) $14\frac{2}{5}$ (n) $9\frac{5}{8}$ (o) $30\frac{5}{14}$ (p) $11\frac{11}{28}$ (q) $9\frac{41}{48}$ (r) $1\frac{43}{56}$

2. (a) $1\frac{1}{2}$ (b) $1\frac{1}{7}$ (c) $1\frac{2}{5}$ (d) $\frac{15}{32}$ (e) $\frac{10}{21}$ (f) $4\frac{3}{8}$
 (g) $1\frac{2}{3}$ (h) 22 (i) $\frac{64}{133}$ (j) $3\frac{3}{4}$ (k) $1\frac{1}{13}$ (l) $1\frac{71}{105}$

3. (a) $1\frac{1}{8}$ (b) $\frac{1}{2}$ (c) $6\frac{33}{40}$ (d) $3\frac{1}{5}$

11.7

4. $\frac{1}{8}$ 5. $\frac{1}{8}$ 6. Volume = $3\frac{3}{8}$ cm³, Surface area = $13\frac{1}{2}$ cm².
7. $4\frac{1}{8}$ litres 8. $37\frac{1}{2}$ miles 9. $2\frac{1}{2}$ m 10. 7 cakes
11. $4\frac{1}{2}$ miles per hour 12. 10 items

11.8 Compound Interest and Depreciation

1. (a) £1272 (b) £1348.32 (c) £1605.87
2. (a) £8144.47 (b) £7990.66 (c) £10 021.16
3. C (£51.94 interest) 4. (a) £900 (b) £284.77 (c) £90.10
5. £4608 6. (a) 6 years (b) (i) 5 years (ii) 8 years
7. £1.78 8. (a) 45.23 million (b) 8 years
9. (a) (i) £3132.04 (ii) 52.2% (b) (i) £6264.08 (ii) 52.2%
10. (a) £180 (b) £571.31

11.9 Reverse Percentage Problems

1. (a) £603.32 (b) £105.58 2. £192 3. £3.22
4. £81 200 5. 550 ml
6. Television - £320, Video recorder - £424, Computer - £1480, Calculator - £14.51
7. £9800
8. £500
9. (a) £10.29 (b) £6.58 (c) £3.37
10. £3501.78

12 Number Patterns

12.1 Simple Number Patterns

- (a) 11, 13, 15, 17 (b) 24, 28, 32, 36 (c) 30, 35, 40, 45
 (d) 42, 49, 56, 63 (e) 54, 63, 72, 81 (f) 36, 42, 48, 54
 (g) 60, 70, 80, 90 (h) 66, 77, 88, 99 (i) 48, 56, 64, 72
 (j) 120, 140, 160, 180 (k) 90, 105, 120, 135 (l) 300, 350, 400, 450
- (a) +3; 20, 23 (b) +8; 42, 50 (c) +5; 32, 37 (d) +11; 61, 72
 (e) +7; 43, 50 (f) $+\frac{1}{2}$; 5, $5\frac{1}{2}$ (g) +9; 49, 58 (h) -3; 11, 8
 (i) -4; 0, -4 (j) -4; -2, -6 (k) -3; -4, -7 (l) -3; -20, -23
- (a) (i) 22 (ii) 242 (iii) 2442 (iv) 24442 (v) 244442
 (b) (i) 1089 (ii) 10989 (iii) 109989 (iv) 1099989 (v) 10999989
 (c) (i) 968 (ii) 9768 (iii) 97768 (iv) 977768 (v) 9777768
 (d) (i) 63 (ii) 693 (iii) 6993 (iv) 69993 (v) 6999993
- (a) (i) $11 \times 11 \times 11 = 1331$, $11 \times 11 \times 11 \times 11 = 14641$
 (ii) Each one is a symmetric number (these are found in Pascal's triangle).
 (b) $11 \times 11 \times 11 \times 11 \times 11 = 11^5 = 161051$. This is *not* a symmetric number.
- (a) (i) 5, 4, 3, 2, 1 (ii) 4, 5, 6, 7, 8
 (iii) In (i), the digits *increase* by 1 each time; in (ii), the numbers *decrease* by 1 each time.
 (b) The numbers sum to 9.

12.2 Recognising Number Patterns

- (a) 35, 41; +6 (b) 36, 45; +8, +9 (c) 7, 4; -3

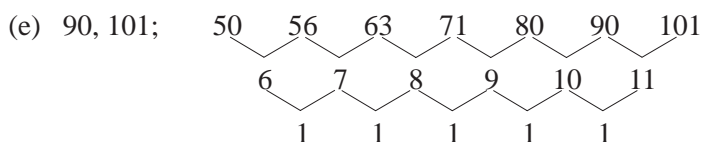
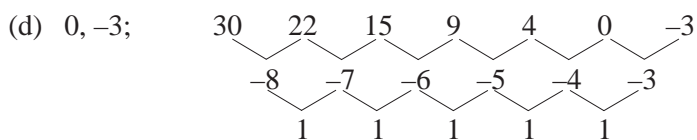

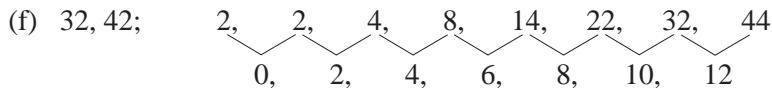

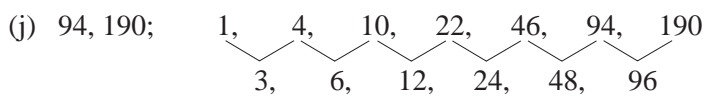
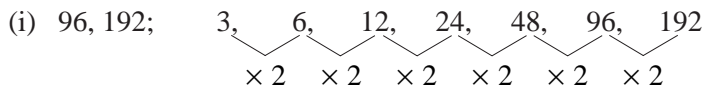
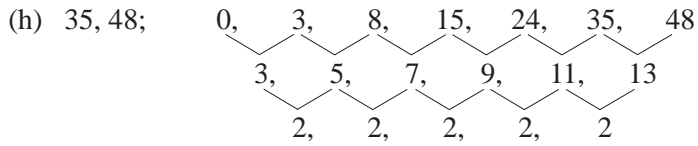

(g) 31, 36; +5

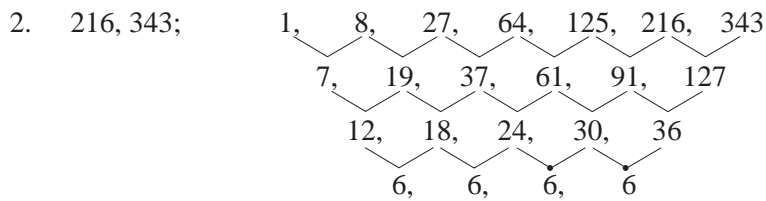

(k) -71, -101; -25, -30



3. (a) (i) 3, 5, 7, 9 (ii) +2 (iii)  ; 11

(b) 4, 7, 10, 13 (ii) +3 (iii)  ; 16

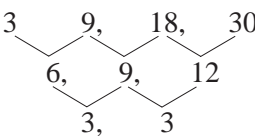
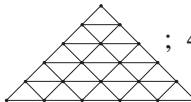
(c)  (ii) +15 (iii)  ; 45

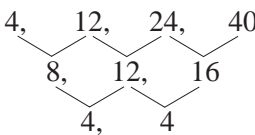
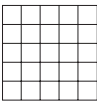
(d)  (ii) +20 (iii)  ; 60

(e) 6, 10, 14, 18 (ii) +4 (iii)  ; 22

4. (a)  +1 to difference to get next number; 21.

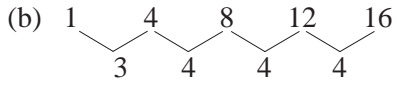
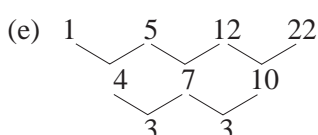
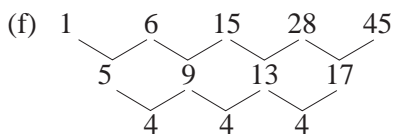
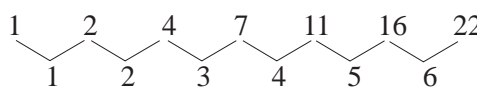
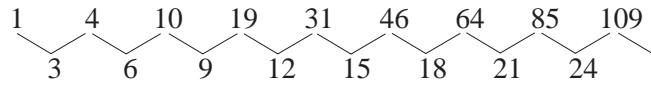
- (b)  If 3 is ignored, the sequence is constant, +4 for next number; 20.
- (c) 5, 8, 11, 14, 17 +3 for next number; 20.
- (d) 4, 6, 8, 10 +2 for next number; 12.
- (e)  +3 for next difference; 35.
- (f)  +4 for next difference; 66.
5. (a) $1^2, 2^2, 3^2, 4^2, \dots$
- (b) (i) $_n = n^2 + 2$ (ii) $_n = n^2 - 2$ (iii) $_n = 2n^2$ (iv) $_n = 4n^2$
6. (a) (ii) $_n = (i)_n + 3$ (iii) $_n = (i)_n - 2$
- (b) (i) $13 + 21 = 34$ (ii) $16 + 24 - 3 = 37$ (iii) $11 + 19 + 2 = 32$
7. Circle 8. 
8. (a) 35, 42 (b) The next term is obtained by adding 7 to the last term.
9. (a) 41, 122 (b) 125, 216
10. (a) $p = 15$ (b) $q = 52 + 15 = 67$
11. (a) It is increasing by 4. (b) (i) Sequence of square numbers. (ii) 49
(iii) 47; minus 2
12. (a) (i) 5, 10, 15, 20, 25, 30, 35, 40 (ii) 5, 0, 5, 0, ..., alternate
(b) Terms are the positive multiples of 3.
- (c) $9 \rightarrow 9 + 1 = 10, \quad 10 \times 2 = 20 \rightarrow 20$
 $12 \rightarrow 12 + 1 = 13, \quad 13 \times 2 = 26 \rightarrow 26$
 $15 \rightarrow 15 + 1 = 16, \quad 16 \times 2 = 32 \rightarrow 32$
 $18 \rightarrow 18 + 1 = 19, \quad 19 \times 2 = 38 \rightarrow 38$
- (d) 85, 109 

12.3 Extending Number Patterns

- (a) 40; 80 (b) 50; 100 (c) 101; 201 (d) 25; 45
 (e) 41; 81 (f) 11; 1 (g) -4; -64 (h) 49; 79
 (i) -1; -11 (j) 32; 72 (k) 52; 102 (l) -42; -92
- (a) (i) $10^2 + 2 = 102$ (ii) $4 + 10 \times 1 = 14$ or $5 + 9 \times 1 = 14$
 (b) (i) 116 (ii) 1428 (iii) 88
- (a) (i) 99 (ii) 41 (b) 4059
- (a) 90 (b) 990
- (a) 28 dots (b) 40 dots (c) 60 dots
- (a) 17 sticks (b) Pattern 58
 (c) (i) 401 sticks (ii) n th pattern needs $(4n + 1)$ sticks

12.4 Formulae and Number Patterns

- (a) 5, 9, 13, 17, 21, 25 (b) -2, 3, 8, 13, 18, 23
 (c) 12, 22, 32, 42, 52, 62 (d) 0, 3, 8, 15, 24, 35
 (e) 3, 9, 19, 33, 51, 73 (f) 2, 4, 8, 16, 32, 64
- (a) $u_n = n^3 - 1$ (b) $u_n = 3n + 5$ (c) $u_n = 8n - 2$ (d) $u_n = n^2 + 1$
- (a) 80 (b) 10 (c) 87 (d) 0 (e) 396 (f) $\frac{1}{2}$
- (a) Because the difference sequence is 7, 7, 7, ..., (b) $u_n = 7n + 1$
- (a) $u_n = 5n - 1$ (b) $u_n = 3n + 8$ (c) $u_n = 6n - 8$
 (d) $u_n = -2n + 102$ (e) $u_n = \frac{1}{2}n + \frac{1}{2}$ (f) $u_n = -7n + 12$
 (g) $u_n = -\frac{1}{2}n + 10\frac{1}{2}$
- (e) $u_n = 0.1n + 0.9$ (g) $u_n = 4n - 1$
- 1, 4, 9, 16, 25, 36 (a) $u_n = n^2 + 2$ (b) $u_n = n^2 - 5$ (c) $u_n = 2n^2$
 (d) $u_n = 2n^2 - 2$ (e) $u_n = -n^2 + 100$
- (a) $u_n = n^3 - 1$ (b) $u_n = n^3 + 9$ (c) $u_n = -n^3 + 200$
- $u_n = 4n + 10$; 14, 18, 22, 26, 30

10. $u_n = 6n + 8$; 68
 11. $u_n = 5n + 2$; 7
 12. (a) $u_8 = 29$, add 4 (b) $n = 100$; 100th term is 397
 13. $u_n = 4n + 3$

14. (b)

| | | | | | |
|-----------------------------|----|----|----|----|----|
| <i>Number of enclosures</i> | 4 | 5 | 6 | 7 | 8 |
| <i>Number of posts</i> | 15 | 18 | 21 | 24 | 27 |

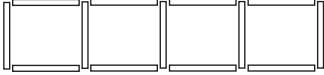
- (c) 63 posts (d) $u_n = 3n + 3$
 15. (a) (i)  (ii) 13 sticks (b) 3 more sticks

- (c) number = $3s + 1$
 16. (a) (i) add 5 (ii) $u_n = 5n + 2$
 (b) area = $n(n + 1) = n^2 + n$

12.5 General Laws

1. (a) $u_n = \frac{n^2}{n + 9}$ (b) $u_n = \frac{2n + 3}{n + 1}$ (c) $u_n = 2 \times 3^{n-1}$ (d) $u_n = 0.9^{n-1}$
 (e) $u_n = 1.2^{n-1}$ (f) $u_n = \frac{2}{3^{n-1}}$ (g) $u_n = 2^n$ (h) $u_n = 2^n + 1$

(i) $u_n = \frac{3n}{n + 3}$

- (b), (d), (f), (i) converge; (a), (c), (e), (g), (h) diverge;
 \downarrow \downarrow \downarrow \downarrow
 2 0 0 3

2. (a) $u_1 = 8$; $u_{n+1} = u_n - 3$ (b) $u_1 = 5$; $u_{n+1} = 4u_n$
 (c) $u_1 = 2$; $u_{n+1} = 2u_n - 1$ (d) $u_1 = 4000$; $u_{n+1} = \frac{u_n}{2}$
 (e) $u_1 = 3$, $u_2 = 3$; $u_{n+2} = u_n + u_{n+1}$
 (f) $u_1 = 1$, $u_2 = 1$, $u_3 = 1$
 $u_{n+3} = u_n + u_{n+1} + u_{n+2}$

3. (a) 1, 3.5, 2.6071, 2.4543, 2.4495 (b) $\sqrt{6} \approx 2.449489743$

4. Yes; converges to 3. If u_1 is a different value it still converges to 3.

5. 0.1, 0.13, 0.1417, 0.14284777, 0.142857142; $\frac{1}{7}$

6. $\frac{1}{3}$; 0.5, 0.25, 0.3125, 0.33203125
7. (a) (i) $40 = 5 \times 8 = 5 \times (5 + 3)$ (ii) $n(n + 3)$
 (b) (i) $40 = 6 \times 7 - 2$ (ii) $(n + 1)(n + 2) - 2$
 (c) $(n + 1)(n + 2) - 2 = n^2 + 3n + 2 - 2 = n^2 + 3n = n(n + 3)$
8. (a) 64 (b) $u_n = 2^{n-1}$ (c) $u_{11} = 1024$, $u_{10} = \frac{1024}{2} = 512$
9. (a) Row 4: 13 15 17 19 Sum = $64 = 4^3$
 (b) Row 10 $\rightarrow 10^3 = 1000$ (c) Row 20 $\rightarrow 20^3 = 8000$ (d) $x + 2$

12.6 Quadratic Formulae

1. (a) 50, 65 (b) 130, 180 (c) 142, 194 (d) $20, 26\frac{1}{2}$ (e) 14, 23
2. 1st term: 4, 2nd term: 4, 6th term: 24 3. 336 4. 22
5. (a) $u_n = n^2 - 4n + 6$ (c) $u_n = n^2 - n + 1$ (e) $u_n = n^2 + 2n - 8$
 (g) $u_n = 3n^2 - 9n + 7$
6. $u_1 = -1$, $u_5 = 15$ 7. $u_n = 2.5n^2 + 2.5n + 4$
8. (a)
- | | | | | | | | |
|----------------|---|----|----|-----|-----|-----|-----|
| | 1 | 15 | 53 | 127 | 249 | 431 | ... |
| 1st difference | | 14 | 38 | 74 | 122 | 182 | ... |
| 2nd difference | | | 24 | 36 | 48 | 60 | ... |
| 3rd difference | | | | 12 | 12 | 12 | ... |

The 1st difference sequence is a quadratic sequence; the 2nd difference sequence is an arithmetic sequence; the 3rd difference sequence is a non-zero constant sequence.

- (c) $6a$ (d) $u_n = n^3 + n^2 + n + 1$
9. (a) triangle $u_n = \frac{1}{2}n^2 + \frac{1}{2}n$, square: $u_n = n^2$, pentagon: $u_n = \frac{3}{2}n^2 - \frac{1}{2}n$
 (c) heptagonal: $u_n = \frac{5}{2}n^2 - \frac{3}{2}n$, octagonal: $u_n = 3n^2 - 2n$
 (d) decagonal: $u_n = 4n^2 - 3n$ and $u_8 = 232$
10. (a) (i) $r_4 = \sqrt{10^2 + 24^2} = 26$ (ii) $r_5 = \sqrt{12^2 + 35^2} = 37$

- (b) (i) $p_{10} = 22$ (ii) $q_6 = 48$ (c) (i) $p_n = 2n + 2$
 (ii) $k = 2$ so $q_n = n^2 + 2n$

11. (a)

| | | |
|----------------------------|----|----|
| <i>Diagram no.</i> | 4 | 5 |
| <i>No. white triangles</i> | 10 | 15 |
| <i>No. black triangles</i> | 6 | 10 |
| <i>Total no. triangles</i> | 16 | 25 |

(b) $T_{10} = 10^2 = 100$

(c) (i) and (ii)

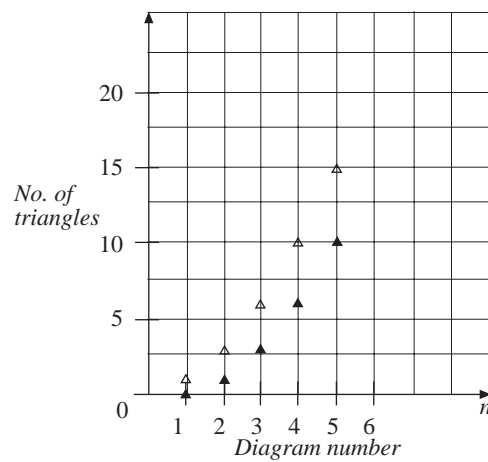

(iii) The two sets of points follow the same pattern, with the white triangles increasing more quickly than the black.

(d) No, this rule is not correct. Number = $\frac{d(d+1)}{2}$

Answers

13 Graphs

13.1 Positive Coordinates

1. A (0, 4), B (1, 3), C (2, 1), D (3, 0), E (4, 3), F (5, 2)
2. Rocky Point (2, 8), Landing Stage (2, 2), Old Ben's Cottage (3, 5)
Old Tower (4, 3), Café (7, 6), Sandy Beach (9, 3), Camp Site (10, 6)
3. (a) rectangle (b) triangle (c) rhombus (d) pentagon (e) hexagon
4. (a) J: (1, 2), (1, 1), (2, 1), (2, 5), (1, 5) and (3, 5)
S: (4, 1), (6, 1), (6, 3), (4, 3), (4, 5) and (6, 5)
5. (a) (2, 3), (3, 2), (4, 3), (5, 2), (6, 3)

6. (a)  (b) (i) A (2, 1) (ii) (B) (1, 5)

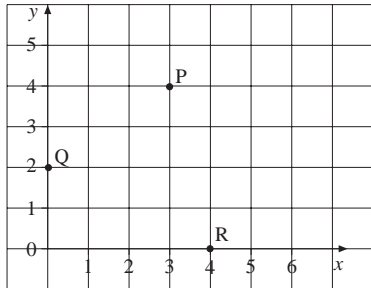

13.2 Coordinates

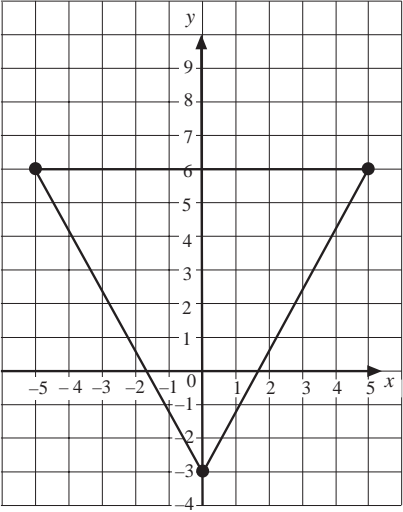
1. A (2, 5), B (4, 3), C (2, 1), D (2, -2), E (5, -3), F (3, -4), G (-5, 4),
H (-3, 3), I (-5, 2), J (-4, -2), K (-2, -3), L (-6, -5)
2. (a) (5, -4), (6, -3) and (-6, -5)
(b) Albany to Alice Springs
(c) Broome to Perth
3. (a) (0, 4), (12.5, -5.5), (-12, 1), (-6.5, -3.5), (-1, -7) (b) (-1, 1)
(c) (10, 0) to (-7.5, -10.5) (d) (-17, -2) (e) (10, 7)
4. (a) triangle (b) 

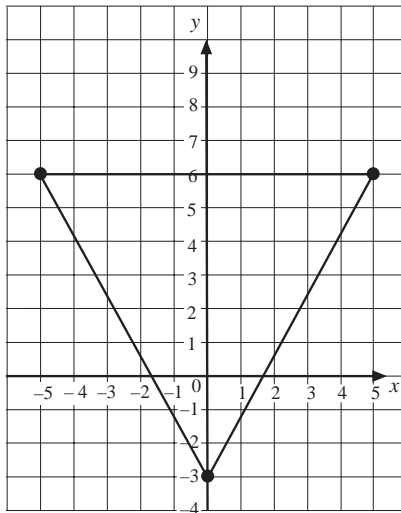

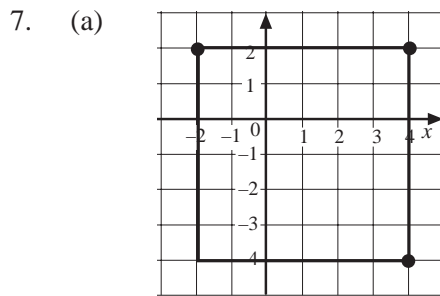
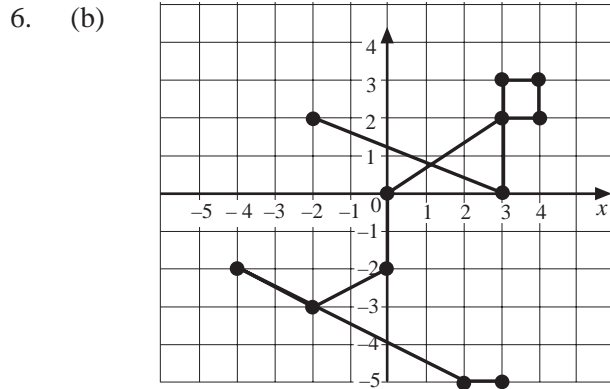

(b) (1, -1)

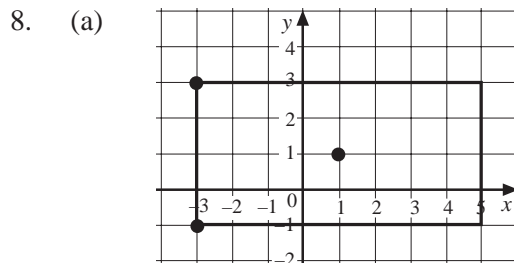

(b) (5, -1), (5, 3)

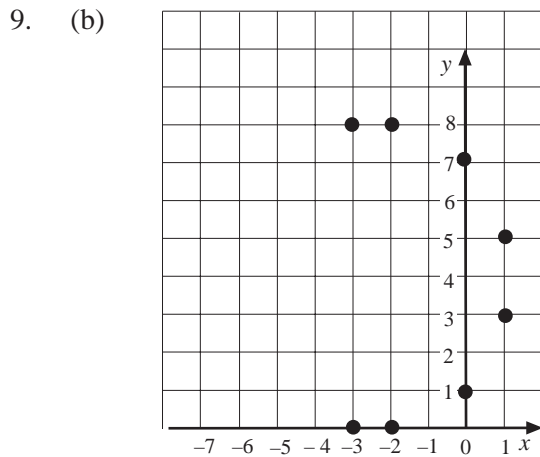

(c) (-4, 0), (-6, 1), (-7, 3), (-7, 5), (-6, 7), (-4, 8)

10. (a) 2 units (b) 4 units (c) $\sqrt{32} \approx 5.66$

13.3 Plotting Straight Lines

1. (a) (4, 6), (1, 3), (-3, 1) (e) (0, 2)
2. (a) (3, 7), (1, 3), (-2, -3) (d) Yes

3. (a) $(3, 7)$, $(0, -2)$, $(-2, -8)$ (d) No

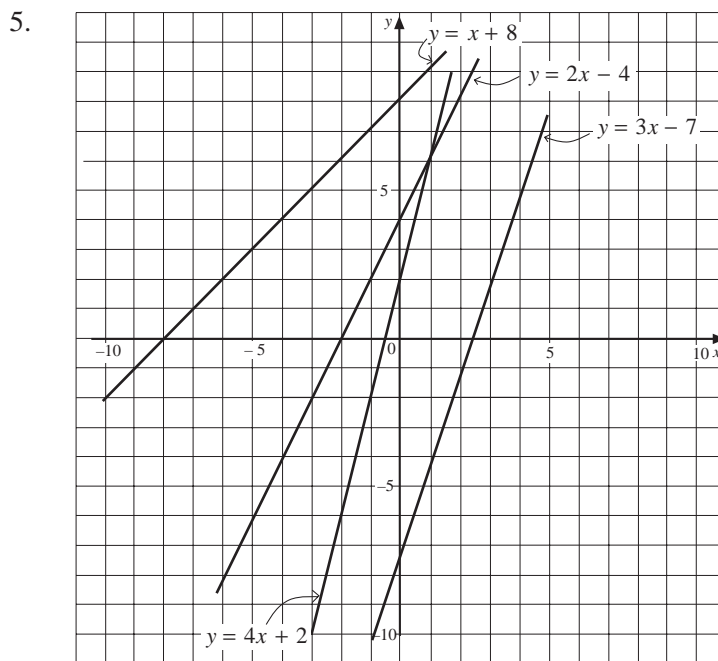
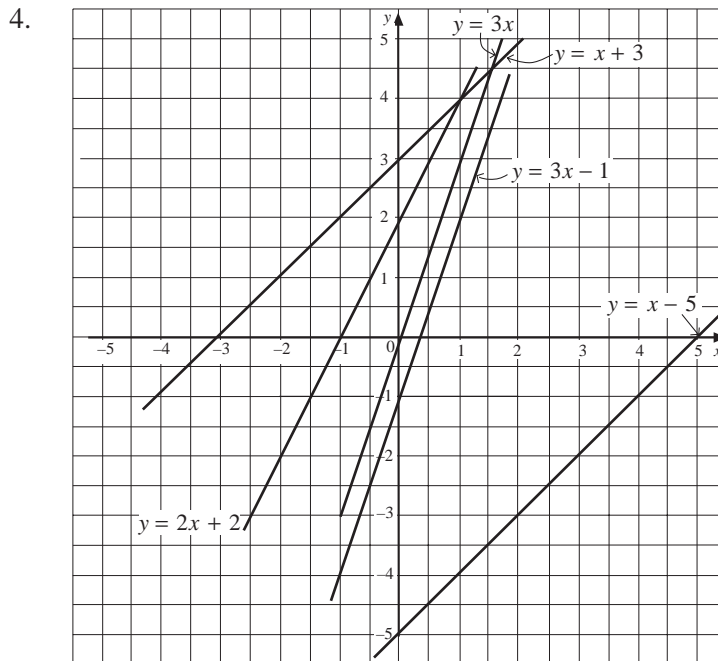

6. (a)

| | | | |
|-----|---|---|----|
| t | 0 | 2 | 4 |
| d | 0 | 8 | 16 |

 (b) $(0, 0)$, $(2, 8)$, $(4, 16)$ (d) x -axis (horizontal)
 (e) y -axis (vertical) (f) 3 hours (g) 14 km

7. (a)

| | | | |
|-----|---|----|-----|
| m | 0 | 10 | 25 |
| p | 0 | 40 | 100 |

 (b) $(0, 0)$, $(10, 40)$, $(25, 100)$

(d)

| | Mark | Percentage |
|--------|------|------------|
| John | 15 | 60 |
| Stuart | 21 | 84 |
| Jenny | 18 | 72 |
| Karen | 20 | 80 |
| Mike | 15 | 60 |

8. (a)

| | | | |
|----|----|----|-----|
| °C | 0 | 20 | 100 |
| °F | 32 | 68 | 212 |

(c) about 27 °C
(d) 86 °F

9. (a) (0, 4), (2, 2), (4, 0) (c) (0, 4) and (4, 0)

10. (c) 18 sq. units

11. (a) see graph
 (b) (6, 4)
 (c) 16 sq. units
 (d) (2, 6), 18 sq. units
 (e) (4, 4), 4 sq. units

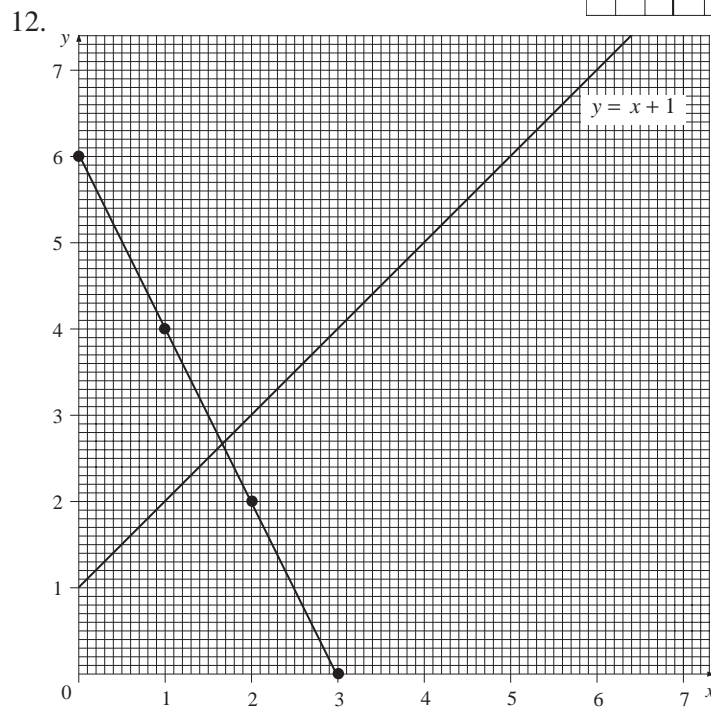
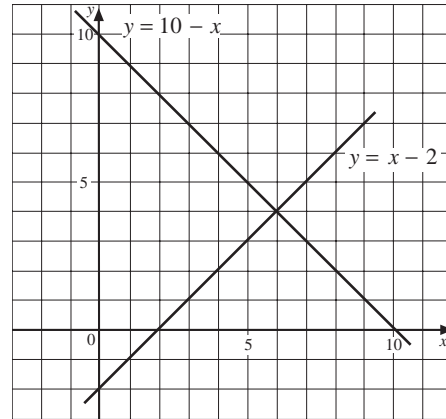

13. (a)

| | |
|-----|-----|
| x | y |
| 0 | 1 |
| 1 | 3 |
| 3 | 7 |

- (c) $y = 2x + 1$ (d) 4

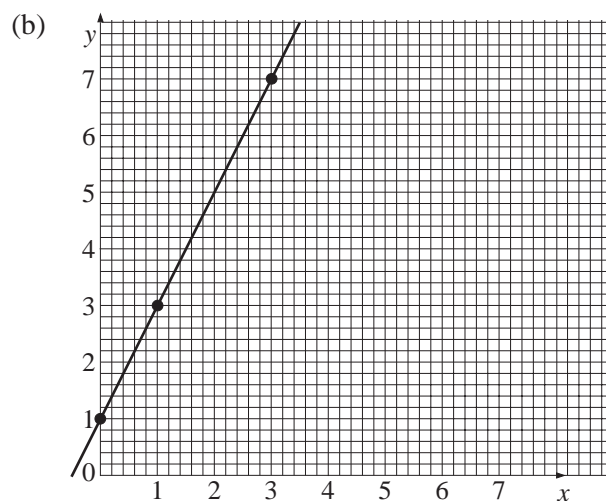

13.3

14. (a) $A (-5, 2), B (1, -4)$

| | | | | | |
|-----|----|----|---|---|---|
| x | -2 | 0 | 2 | 3 | 4 |
| y | -4 | -2 | 0 | 1 | 2 |

(c) see graph

(d) $\left(-\frac{1}{2}, -\frac{5}{2}\right)$

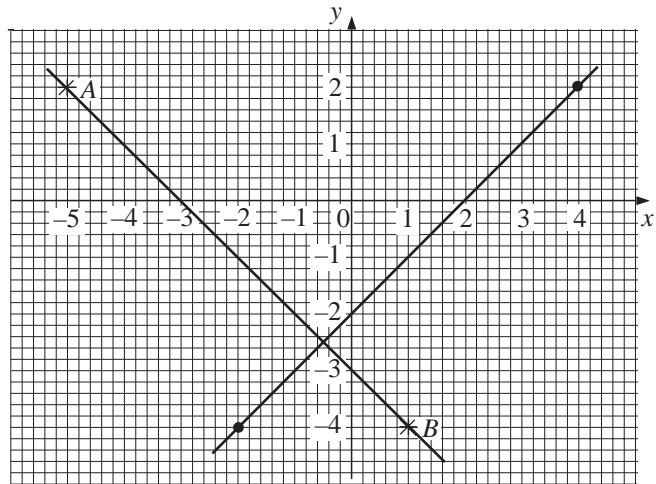

15. (a)

| | | | | |
|-----|---|---|----|----|
| IN | 1 | 2 | 3 | 6 |
| OUT | 1 | 7 | 13 | 31 |

(b) (iii) (4, 19)

16. (a)

| | |
|----|-----|
| IN | OUT |
| 3 | 2 |
| 5 | 8 |
| 6 | 11 |
| 8 | 17 |

(c) They lie on a straight line

13.4 Plotting Curves

1. (a)

| | | | | | | | |
|-----|----|----|----|----|----|----|---|
| x | -3 | -2 | -1 | 0 | 1 | 2 | 3 |
| y | 4 | -1 | -4 | -5 | -4 | -1 | 4 |

(b) $(-3, 4), (-2, -1), (-1, -4), (0, -5), (1, -4), (2, -1), (3, 4)$

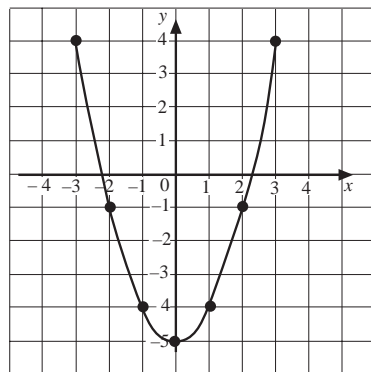

2. (a)

| | | | | | | | |
|-----|----|----|---|----|---|---|---|
| x | -2 | -1 | 0 | 1 | 2 | 3 | 4 |
| y | 8 | 3 | 0 | -1 | 0 | 3 | 8 |

(b)

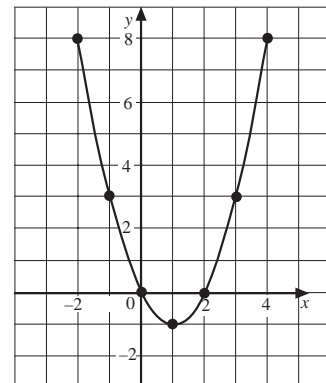

3.

| | | | | | | | |
|-----|----|----|----|---|---|---|----|
| x | -3 | -2 | -1 | 0 | 1 | 2 | 3 |
| y | -3 | 2 | 5 | 6 | 5 | 2 | -3 |

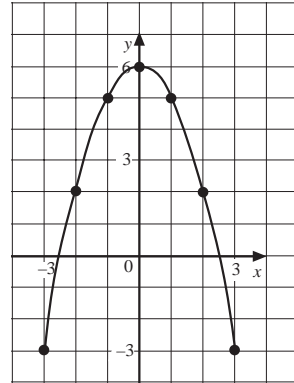

4. (a)

| | | | | | | |
|-----|----|----|----|----|---|---|
| x | -2 | -1 | 0 | 1 | 2 | 3 |
| y | 4 | 0 | -2 | -2 | 0 | 4 |

(b) 0.5 (c) -2.25

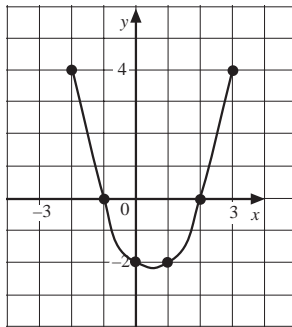

5. (a)

| | | | | | |
|-----|----|----|---|---|---|
| x | -2 | -1 | 0 | 1 | 2 |
| y | -6 | 0 | 0 | 0 | 6 |

(c) $(-0.5, 0.375)$, $(0.5, -0.375)$

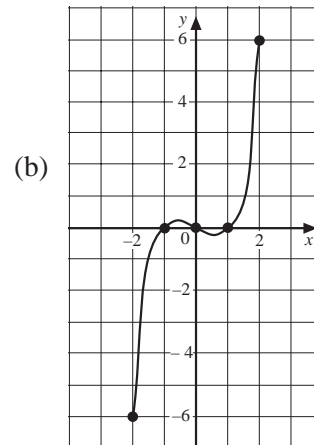

6.

| | | | | | | |
|-----|----|-----|---|------|---|-----|
| x | 1 | 2 | 3 | 4 | 5 | 6 |
| y | 15 | 7.5 | 5 | 3.75 | 3 | 2.5 |

7. (a) $xy = \text{area} = 120 \text{ cm}^2$

(b)

| | | | | | | |
|-----|----|----|----|----|-----|----|
| x | 5 | 10 | 15 | 20 | 25 | 30 |
| y | 24 | 12 | 8 | 6 | 4.8 | 4 |

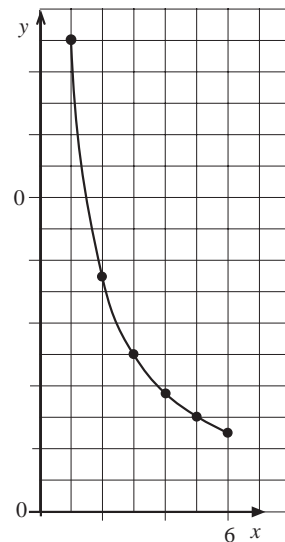
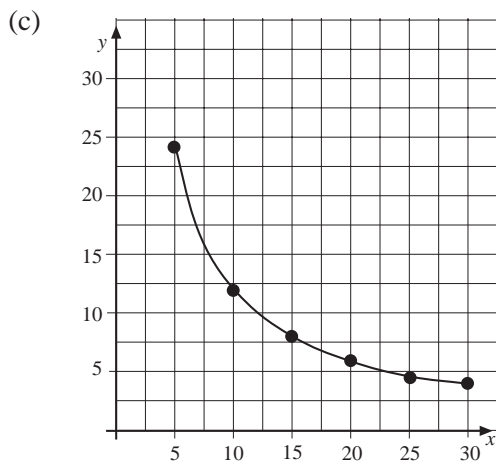

(d) width about 17 cm

(e) about 8.6 cm

8. (a) Volume = $2 \times x \times x = 2x^2$ (b)

| | | | | | | |
|-----|---|-----|-----|-----|-----|------|
| x | 0 | 0.5 | 1.0 | 1.5 | 2.0 | 2.5 |
| V | 0 | 0.5 | 2.0 | 4.5 | 8.0 | 12.5 |

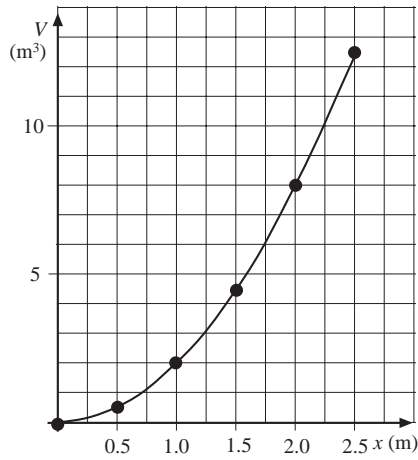

- (c) about 9.7 m^2
 (d) (i) 2.2 m (ii) 1.6 m

9. (a)

| | | | | | |
|-----|---|----|----|---|----|
| t | 0 | 1 | 2 | 3 | 4 |
| h | 0 | 13 | 16 | 9 | -8 |

- (b) about 3.6 seconds
 (c) just over 16 metres

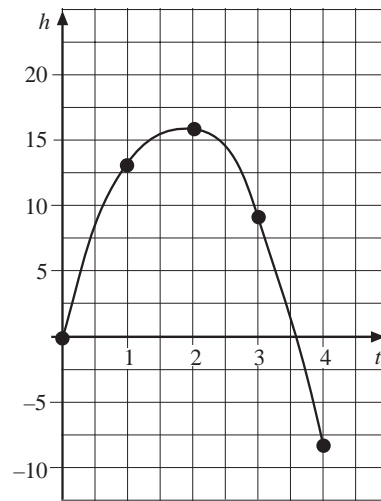

10. (a)

| | | | | | | | | | |
|-----|----|----|----|-----|---|----|---|---|---|
| x | -4 | -3 | -2 | -1 | 0 | 1 | 2 | 3 | 4 |
| y | -3 | -4 | -6 | -12 | 0 | 12 | 6 | 4 | 3 |

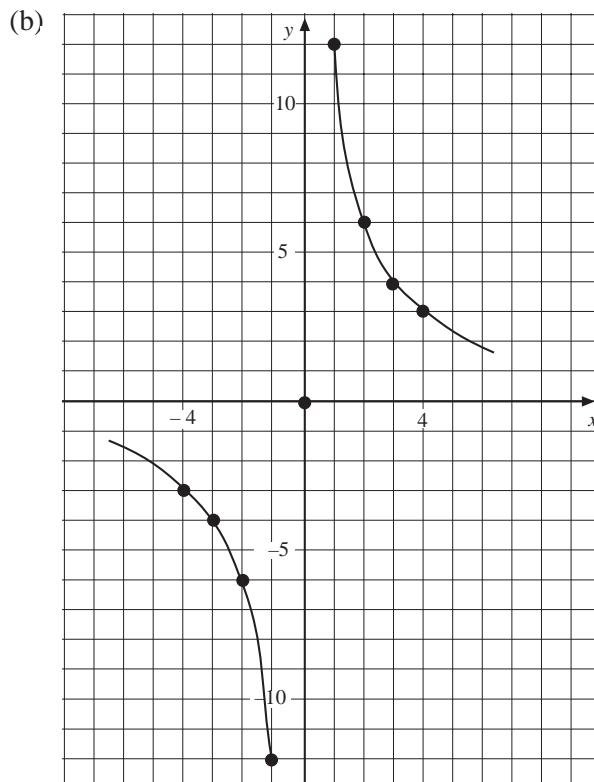

- (d) y gets larger and larger
 (e) y gets negatively larger and larger

11. (a)

| | | | | | | | |
|-----|----|----|----|---|---|---|---|
| x | -3 | -2 | -1 | 0 | 1 | 2 | 3 |
| y | 0 | 1 | 2 | 3 | 4 | 5 | 6 |

(b)

| | | | | | | | |
|-----|----|----|----|---|---|---|---|
| x | -3 | -2 | -1 | 0 | 1 | 2 | 3 |
| y | 9 | 4 | 1 | 0 | 1 | 4 | 9 |

(c)

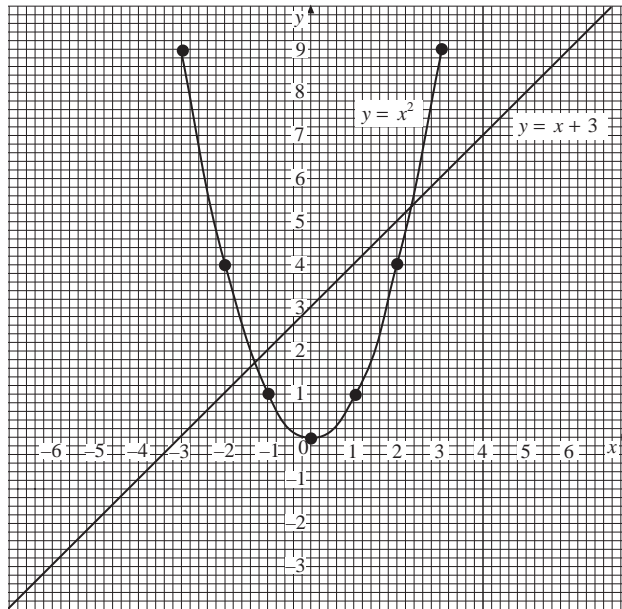

12. (a)

| | | | |
|-----|----|----|----|
| x | -5 | 5 | 6 |
| y | 25 | 25 | 36 |

(b)

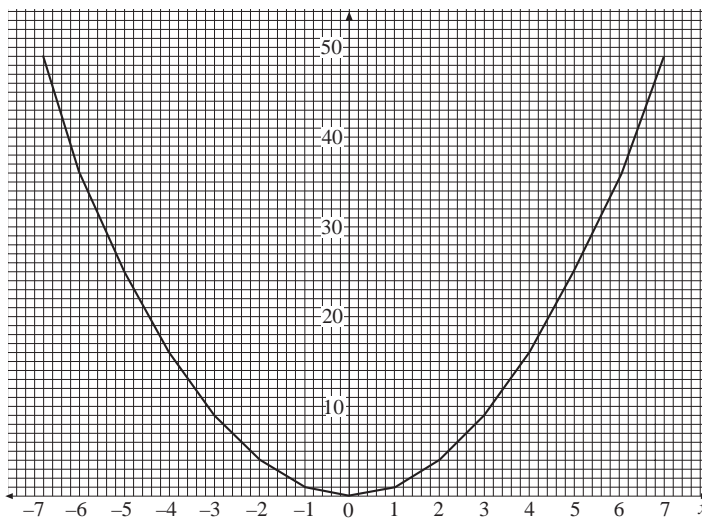

13. (a) £320

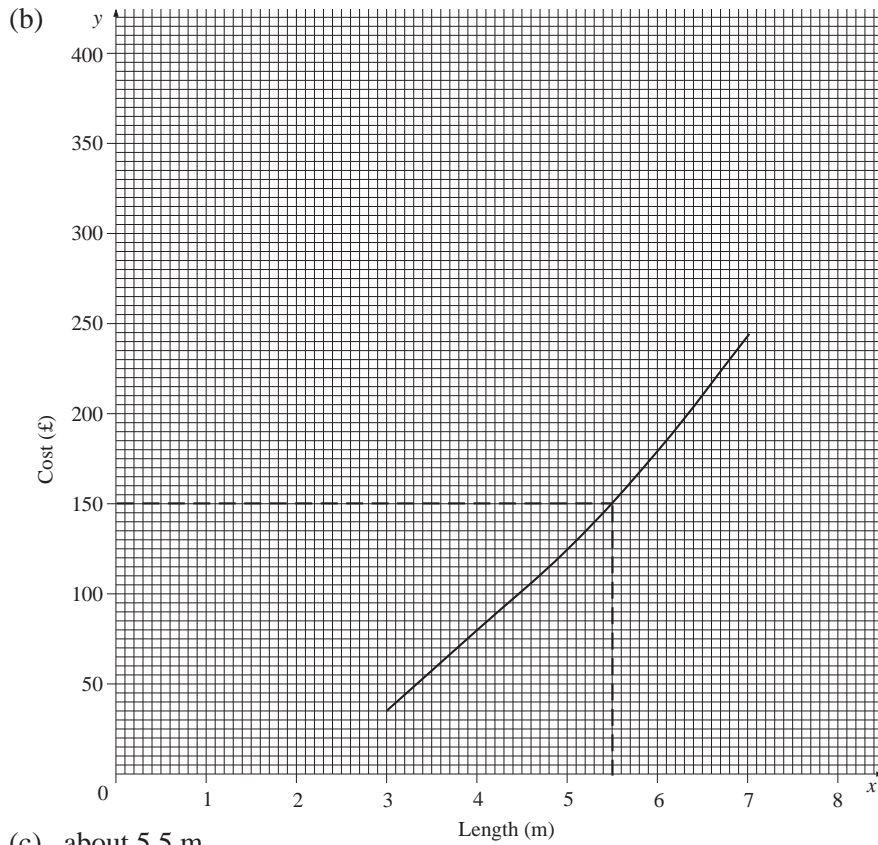

(c) about 5.5 m

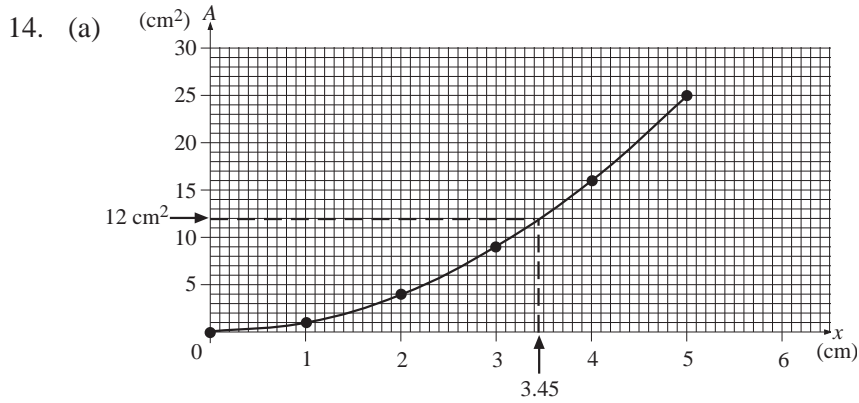

(b) $A = x^2$ (c) about 3.45 cm

13.5 Gradient

1. 3
2. $AB : 1, CD : 2, EF : 4$
3. (a) CD, AB, KL, GH (b) EF, IJ
4. $\frac{2}{10} = \frac{1}{5}$ (= 0.2)
5. 2, 1, $\frac{1}{5}$

6. (a) $\frac{1}{2}$ (b) 5 (c) 4 (d) $\frac{4}{5}$ (e) 1 (f) 7
7. (a) $-\frac{1}{2}$ (b) $-\frac{5}{4}$ (c) -1 (d) $-\frac{5}{4}$ (e) 1 (f) $\frac{1}{6}$
8. AB: $-\frac{1}{3}$, BC: 0, CD: $-\frac{6}{5}$, DA: 5
9. (a) (2, 5), (0, 1), (-2, -3) (c) 2 (e) same gradient
10. (c) 3 (d) gradient of $y = 4x - 1$ is 4; gradient of line $y = 5x + 1$ is 5
(e) coefficient of x is the gradient of a straight line (f) 7
11. (a) 1 (b) -1 (c) 4 (d) -2

13.6 Applications of Graphs

1. (a) 2.7 kg (b) 3.6 kg (c) 11 lbs (d) 6.6 lbs
2. (a) 22.5 litres (b) 6.7 gallons
3. (a) 3 (b) AB: 20 m/s ; CD: 5 m/s ; EF: 10 m/s ; GH: 10 m/s (c) AB
4. (a) 150 s (b) AB and CD; 5 m/s (c) EF; $\frac{10}{3}$ m/s
5. $16 + 88 + 4 = 108$ metres
6. (a) 20 m (b) 80 m (c) 120 m
7. AB: 0.5 m/hour ; BC: not moving ; CD: 2 m/hour
8. 14 m
9. (a) 7 m/s ; 2 m/s (b) 4.78 m/s
10. Jodie ran faster for the first 10 s but then slowed down until Wendy caught up at the end of the school field. While Wendy rested, Jodie returned at a constant speed until reaching the starting point, whilst Wendy (after her rest) ran faster, reaching the starting point at the same time.
11. (a) 12.5 miles (b) 56.25 miles (c) 6600 mm (d) 35 m
12. (a) 75 km/hour; 20.83 m/s (b) 0.4375 mm/s; 0.04375 m/s
(c) 60 m/hour ; $\frac{1}{60}$ m/s (d) 0.5 m/min ; $\frac{1}{120}$ m/s
13. (a) 09.36 (b) 7 km (c) 90 mins (d) 4 km/hour
14. (a) 82 seconds from the start (b) 8.5 m (c) Robert – steeper slope
15. (a) about 4300 (b) metres

13.7 Scatter Plots and Lines of Best Fit

1. (c) maths and science (d) not for maths and French
2. (c) 70 miles (d) 4.3 hours
3. (c) £300 (d) 6.5 hours

4. (c) 120 cm (d) 57 kg
5. (b) 17 s (c) 7 s
6. (c) men: about 210 s; women about 220 s
(d) it looks as if the women will catch up the men, but this is probably not realistic
8. (b) positive correlation
9. (b) the value decreases as they get older
10. (b) 68
11. (b) (i) 68.5 cm (ii) the data points do not fit exactly on a straight line
12. (a) there is positive correlation between the marks (b) 6 or 7
13. (a) negative correlation (b) about 115 mm

13.8 The Equation of a Straight Line

1. (a) $y = 2x + 4$ (b) $y = 3x - 5$ (c) $y = \frac{1}{2}x + 2$
(d) $y = -2x + 1$ (e) $y = \frac{3}{4}x - 3$
2. (a) gradient = 2, y-intercept = 3 (b) gradient = 4, y-intercept = -2
(c) gradient = $\frac{1}{2}$, y-intercept = 1 (d) gradient = $\frac{2}{3}$, y-intercept = -4
(e) gradient = 4, y-intercept = 8 (f) gradient = 3, y-intercept = -21
(g) gradient = $\frac{1}{2}$, y-intercept = $\frac{5}{2}$ (h) gradient = $\frac{1}{4}$, y-intercept = $-\frac{5}{2}$
3. (a) 1 (b) -1 (c) $y = x - 1$
4. A : $y = x + 7$ B : $y = x + 6$ C : $y = 2x + 2$
D : $y = \frac{8}{5}x + 2$ E : $y = \frac{3}{10}x + 1$ F : $y = \frac{1}{4}x + 1$
5. (a) 2, -8 (b) -3, 2 (c) 4, -3 (d) $\frac{1}{2}$, 2
(e) -2, 8 (f) -3, 4 (g) -1, 8 (h) -3, 15
6. (a) $y = 2 + 2x$ (b) $y = \frac{1}{2}x$ (c) $y = 6 - \frac{1}{3}x$ (d) $y = 6 - 2x$
7. A : $y = 5 - \frac{1}{2}x$ B : $y = 4 + \frac{4}{3}x$ C : $y = -3 + 2x$
D : $y = -2 - \frac{2}{5}x$ E : $y = -7 + x$ F : $y = -5 + \frac{2}{5}x$
8. (a) $y = 3 + \frac{1}{50}x$ (b) $y = 10 + \frac{1}{25}x$
9. (b) $y = 19 + \frac{3}{4}x$ ($y = \text{temperature}, x = \text{height}$)

10. (a) $y = 4.5x$ (c) $y = \frac{11}{20}x$ ($y = \text{litres}, x = \text{pints}$)
11. (b) $y = 20 - 10x$ ($y = \text{velocity}, t = \text{time}$) (c) 20 ms^{-1}
12. $c = 3$
13. $c = -12$
14. $m = 5$
15. (a) £32.50 (b) (i) $\frac{1}{2}$ (ii) increase in charge for unit increase in time
 (c) $c = 10 + \frac{1}{2}t$ (d) 148 minutes
16. (b) $y = 5 + w$
17. (b) (i) 32.5°C (ii) 68 grams (c) (i) $a = 0.4, b = 50$ (ii) 88 grams
18. (a) $T = 20 + 30P$ (b) (i) (4, 140) (ii) about 2.7 lbs

13.9 Horizontal and Vertical Lines

1. A: $x = -7$; B: $x = -4$; C: $x = 3$; D: $x = 8$; E: $y = 3$; F: $y = -5$

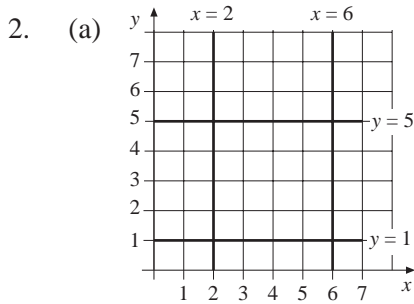

- (b) (2, 1), (2, 5), (6, 1), (6, 5)
 (c) 16 sq. units

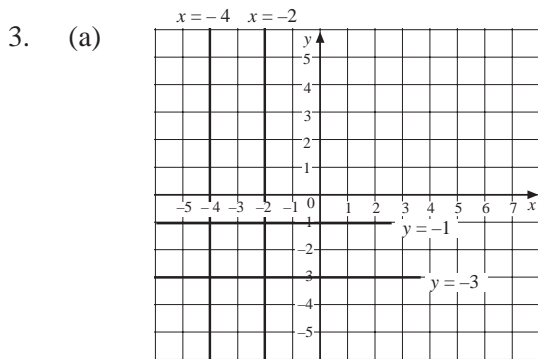

- (b) (-3, -2)

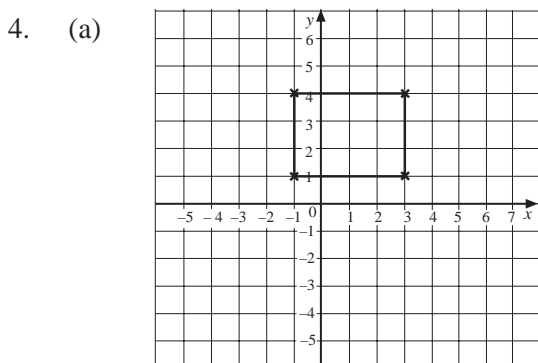

- (b) $x = -1, x = 3, y = 1, y = 4$

5. (a)

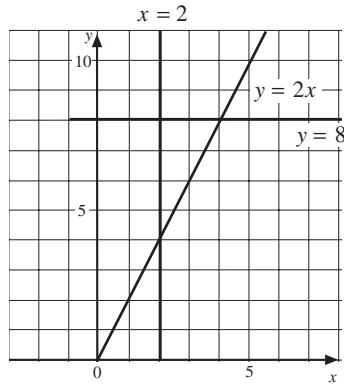

(b) 4 sq. units

13.10 Solution of Simultaneous Equations by Graphs

1. (a) (3, 5) (b) (7, 1) (c) (0, -1) (d) (6, -2)
 (e) (-3, -7) (f) (-6, 0)

2. (c) (2, 1)

3. (a) (0, 2) , (2, 4) , (6, 8) (c) (1, -1) , (2, 2) , (4, 8)
 (e) (3, 5)

4. (d) (i) (3, 2) (ii) (-1, -2) (iii) (1, 4)

5. (a) (4, 8) (b) (2, 2) (c) (4, -2)

6. (a) $y = 1 + 3x$, $y = 6 - 2x$ (c) (1, 4)

7. (a) (5, 2) (b) (2, 1) (c) $\left(-\frac{3}{2}, \frac{11}{2}\right)$

8. (a) $x + y = 20$, $y - x = 14$ (b) $y = 20 - x$, $y = 14 + x$
 (c) (3, 17)

9. (a) $2x + 4y = 40$ (b) $y = 10 - \frac{1}{2}x$ (c) $3x + 2y = 36$

(d) $y = 18 - \frac{3}{2}x$ (f) £8 (g) £6

10. (a) $x + y = 28$, $2x + 5y = 80$

(b) $y = 28 - x$, $y = 16 - \frac{2}{5}x$ (c) 8

11. $x = 2$, $y = 5$

12. (b) $y = x - 3$ (c)

| | | | |
|---|---|---|----|
| x | 3 | 7 | 10 |
| y | 0 | 4 | 7 |

 (d) $x = \frac{17}{2}$, $y = \frac{11}{2}$

13. (a) (i)

| | | | |
|---|-----|-----|-----|
| x | 100 | 200 | 300 |
| y | 15 | 18 | 21 |

 (b) (i) 400 (ii) £24 (c) B, 400

14. (a) (ii) $x = 1.5$, $y = 3.1$ (b) $x = \frac{20}{13}$, $y = \frac{40}{13}$

15. $x \approx 1.9$, $y \approx 2.8$

13.11 Graphs of Common Functions

- (a) reciprocal (b) quadratic (c) linear (d) cubic
(e) quadratic (f) reciprocal
- (a) cubic (b) reciprocal (c) linear (d) cubic
(e) quadratic (f) reciprocal
- B
- B and C
- (a) C (b) D (c) A (d) B
- (a) D (b) A (c) B (d) C
- (a) (i) $y = 1 - x^2$ (ii) $2y = 2 + x$ (iii) $y = x^2$ (iv) $xy = 1$
(b)

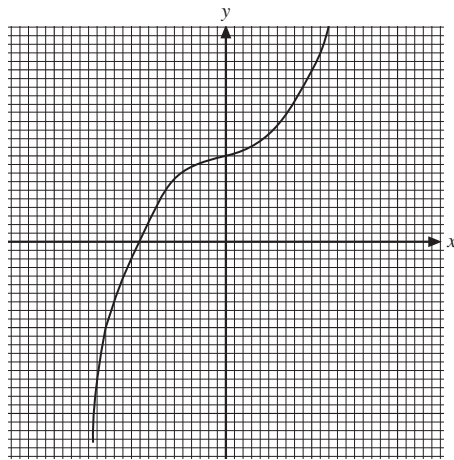

13.12 Graphical Solutions of Equations

- 1.26 and 1.46
- $x = -2$ or 1
- $x = 3$ or -2 ; $x^2 - x - 6 = 0$
- (a) $x = 0, -2, 1$ (b) no solutions (c) $x \approx \pm 1.5$
(d) $x \approx 2.1$ and -0.9
- (a) $x = -3, 1$ (b) $x \approx 0.73, -2.73$ (c) $-0.6, -3.4$; $-1, a < -1$
- about 1.3
- (a) $x = -2, -1, 1$ (b) about $x = 1.5$ (c) $x = -2.25, -0.5, 0.8$

14 Loci and Transformations

14.1 Drawing and Symmetry

2. (a) 5 cm (b) 7.8 cm (c) 3.2 cm (d) 7.8 cm

3. (a) 2 cm (b) 2.5 cm (c) 3 cm (d) 5 cm

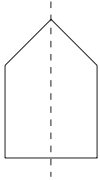
4. (a)  (i) One line of symmetry (ii) 1

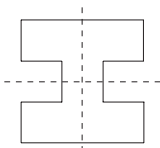
(b)  (i) Two lines of symmetry (ii) 2

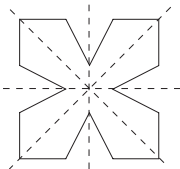
(c)  (i) Four lines of symmetry (ii) 4

(d) (i) No lines of symmetry (ii) 2

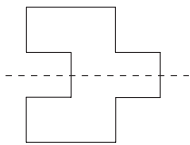
(e)  (i) One line of symmetry (ii) 1

(f) (i) No lines of symmetry (ii) 2

5. (a)  (b) 3

6. (a) 2, 2 (b) 1, 1 (c) 4, 4 (d) 1, 1

7. (a) A (b) D, E (c) C, F (d) B, D, E (e) C, F

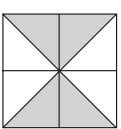
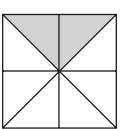
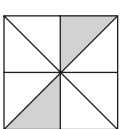
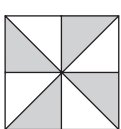
8. (a)  (b)  (c)  (d) 

14.2 Scale Drawings

1. (a) 6 m by 5 m (b) 32.5 m^2 (c) 10.5 m
2. (a) 3.6 m, 2.4 m (b) 60 cm by 60 cm (c) 60 cm by 180 cm
(d) 3.78 m^2
4. (a) 3 m by 3.25 m (b) 1.75 m (c) 0.9375 m^2 (d) 9.75 m^2
5. (b) 4.2 m, 5.8 m
6. (a) 4.8 m (b) 3.6 m (c) 2.5 cm by 1.875 cm (d) 0.75 cm
7. (a) 8 cm by 10 cm (b) 16 cm by 20 cm (c) 4 cm by 5 cm
8. (a) $1 : 175 \text{ m}^2$, $2 : 162.5 \text{ m}^2$, $3 : 400 \text{ m}^2$, $4 : 237.5 \text{ m}^2$, $5 : 350 \text{ m}^2$
9. (a) (i) 5 m (ii) 16 cm (b) $8\frac{1}{2}$ feet
10. (a) 2 cm (b) 13.4 cm

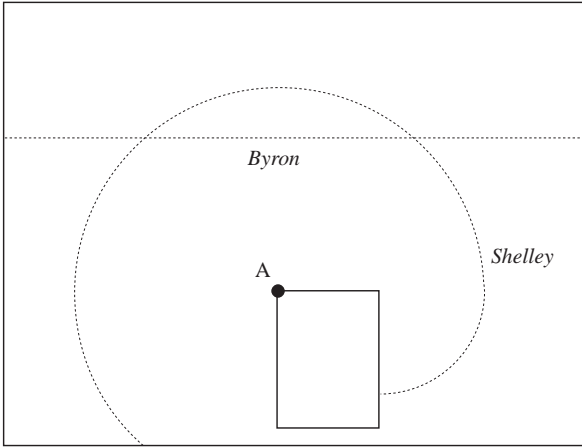
11. (a)  (b) 7000 cm^2

12. (b) (i) (300, 0, 250) (ii) (0, 400, 100) (c)

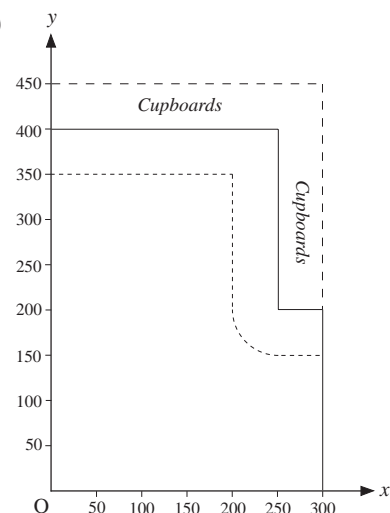

14.3 Constructing Triangles and other Shapes

2. (a) 4.4 (b) $AC \approx 3.1$ cm, $BC \approx 4.4$ cm (c) $AB \approx 10.4$ cm
 (d) 46.6° (e) $AC \approx 3.6$ cm (f) $BC \approx 11.6$ cm
3. 4.7 cm
4. 29.0° , 75.5° , 75.5°
7. (b) 4.6 cm, 7.8 cm
9. 2.6 cm
10. 48°
13. (a) 26 cm

14.4 Enlargements

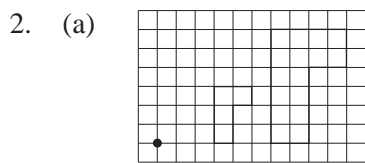
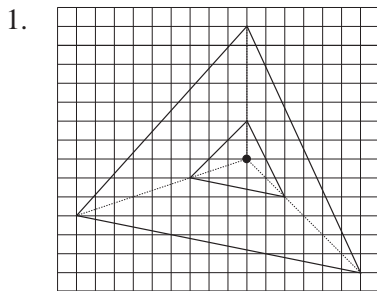

Scale factor: 2

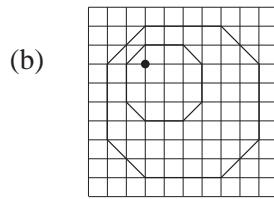

Scale factor: 2

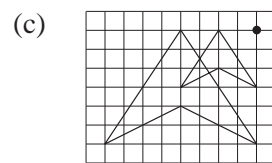

Scale factor: 2

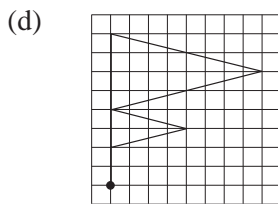

Scale factor: 2

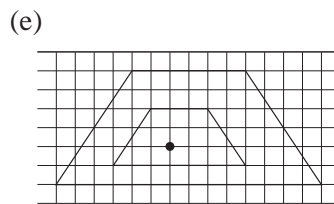

Scale factor: 3

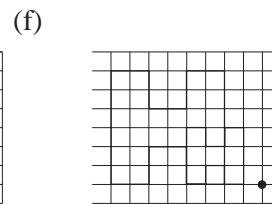

Scale factor: 3

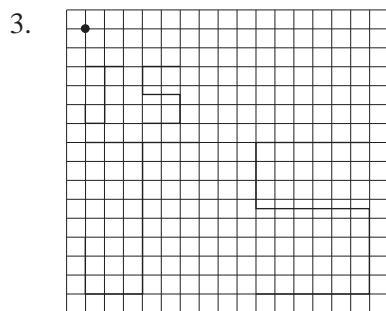

4. (a) 2 (b) 5 (c) 3 (d) 2.5 (e) 4 (f) 1.5

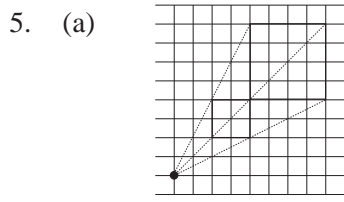

Scale factor: 2

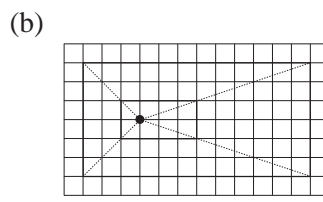

Scale factor: 2

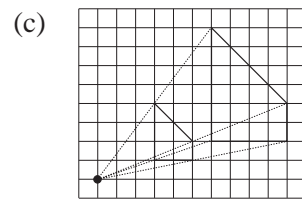

Scale factor 2

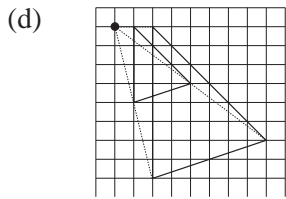

Scale factor: 2

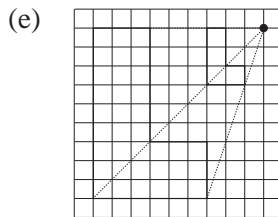

Scale factor: 3

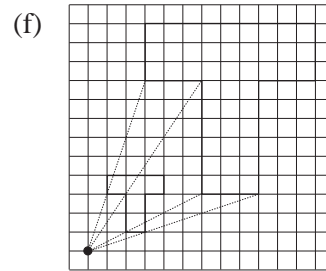

Scale factor: 3

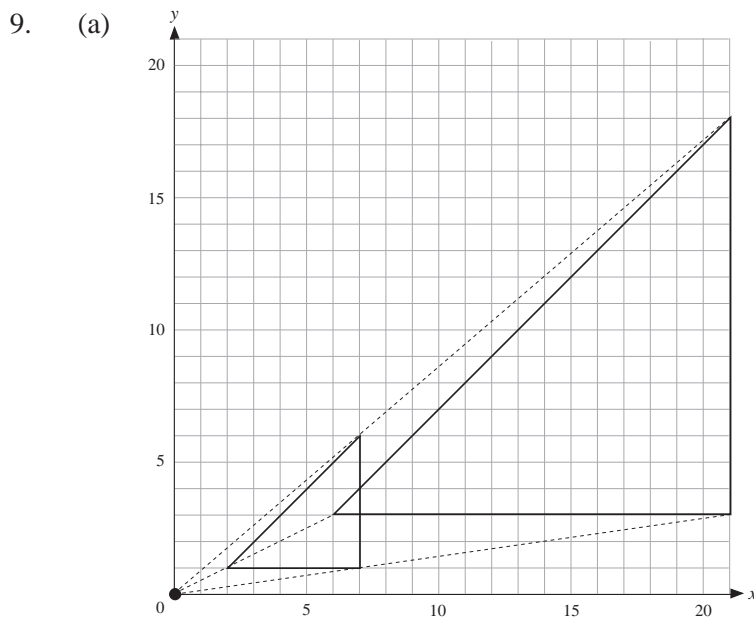
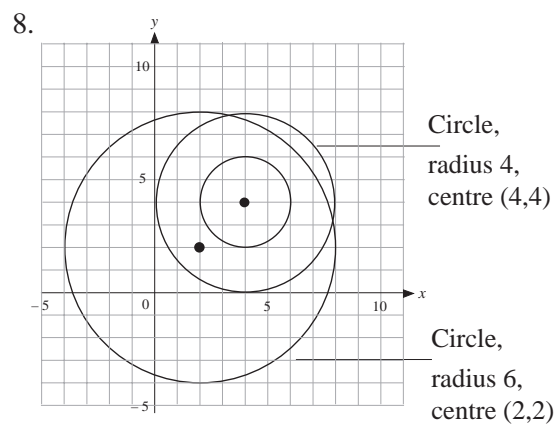
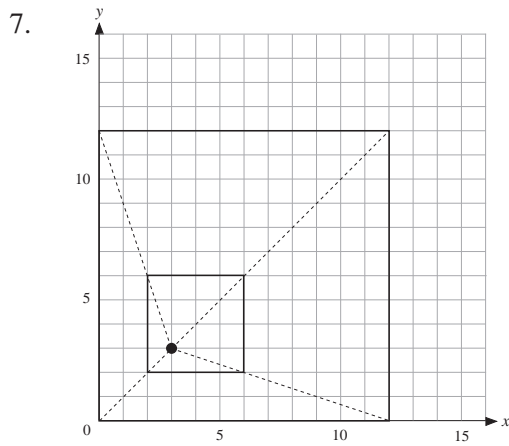

(b) 3

(c) (0, 0)

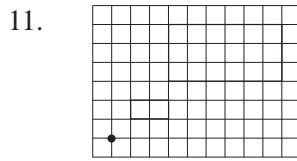

12. (a)

| | | | |
|---|---|----|----|
| 1 | 2 | 3 | 4 |
| 4 | 8 | 12 | 16 |
| 1 | 4 | 9 | 16 |

(b)

| |
|----|
| 8 |
| 32 |
| 64 |

14.5 Reflections

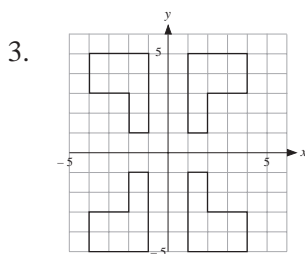
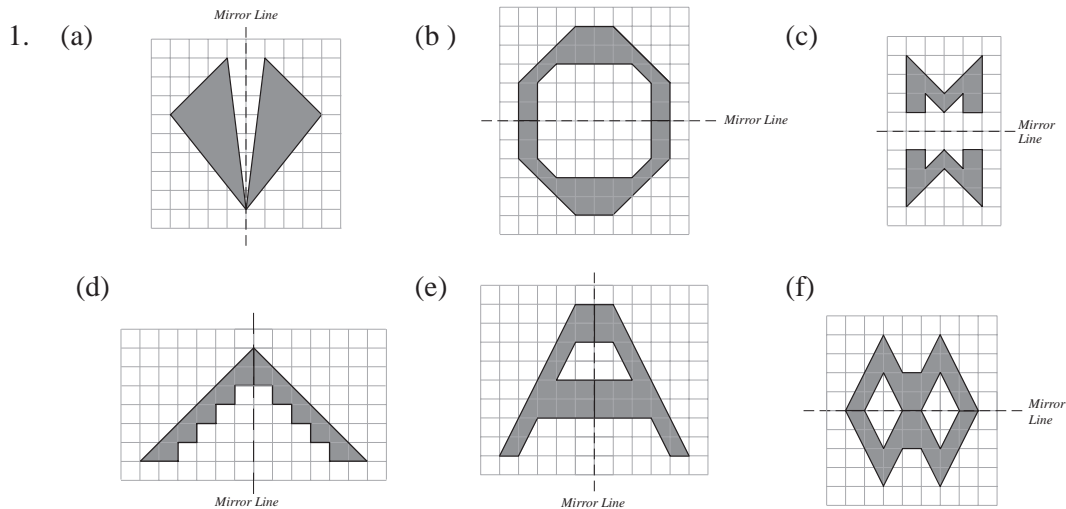

- (c) $(-1, -1), (-1, 5), (-4, 5), (-4, 3), (-2, 3), (-2, 1)$
- (d) $(-1, -1), (-1, -5), (-4, -5), (-4, -3), (-2, -3), (-2, -1)$
- (e) Reflect original shape in x -axis

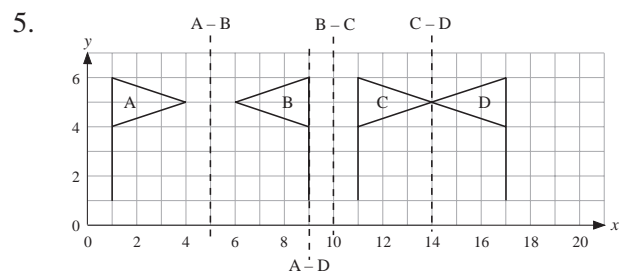
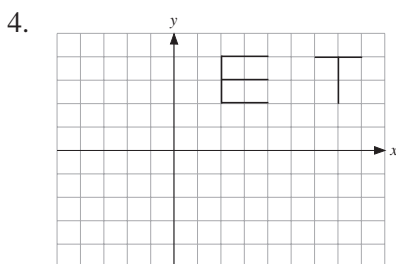

- 6. (b) (iii) x coordinates become negative, y coordinates stay the same.
- (c) (iii) y coordinates become negative, x coordinates stay the same.

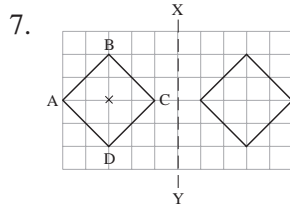

8. (a) 5 square units

(b)

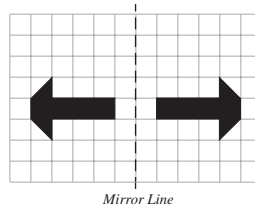

14.6 Construction of Loci

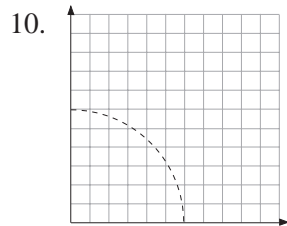
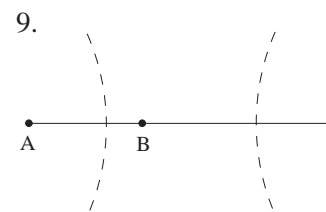
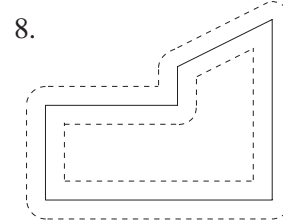
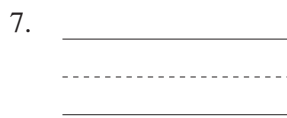
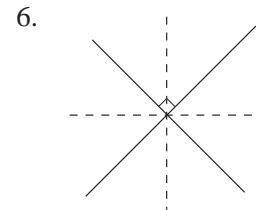
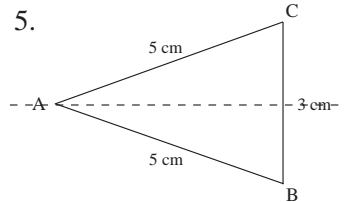
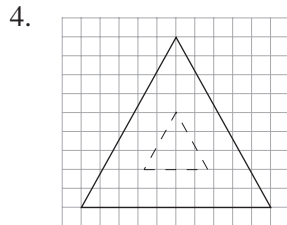
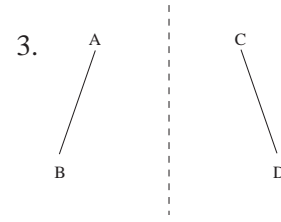
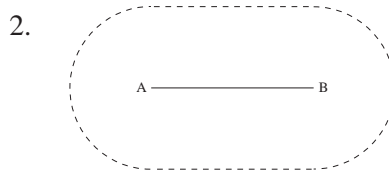
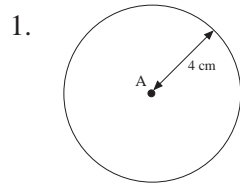

11. (a) (i)

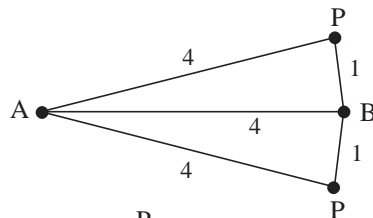

(ii)

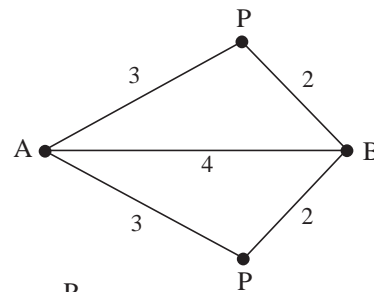

(iii)

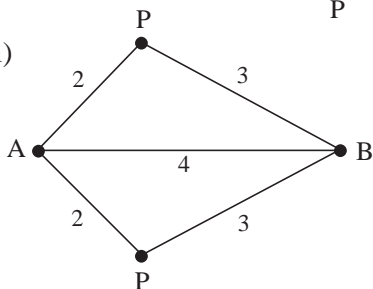

(iv)

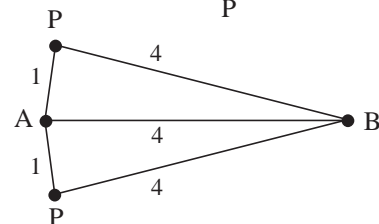

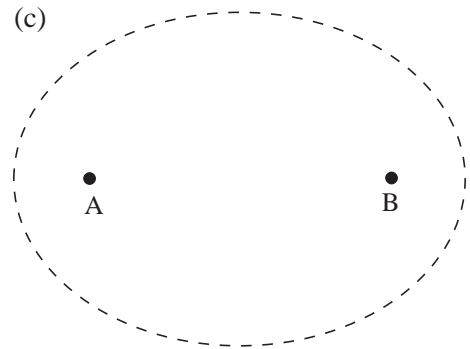
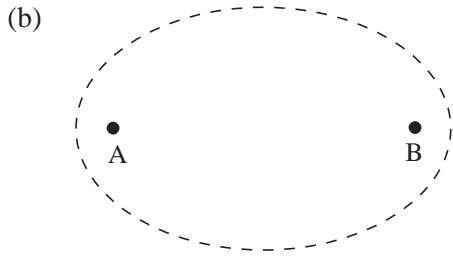

14.7 Enlargements which Reduce

1. (a) $\frac{1}{3}$ (b) $\frac{1}{2}$ (c) $\frac{1}{6}$ (d) $\frac{3}{4}$ (e) $\frac{2}{3}$ (f) $\frac{1}{2}$

2. (a) $\frac{1}{5}$, (8, 7) (b) $\frac{2}{3}$, (13, 9) (c) $\frac{1}{4}$, (9, 1)

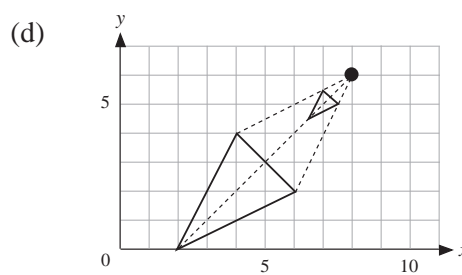
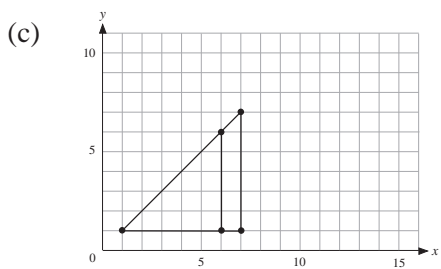
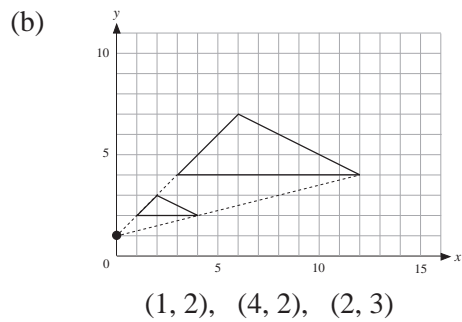
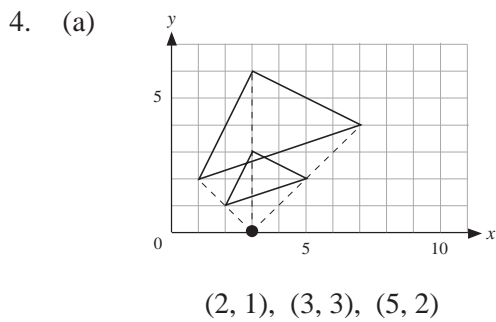
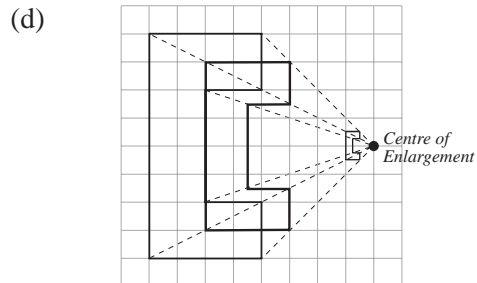
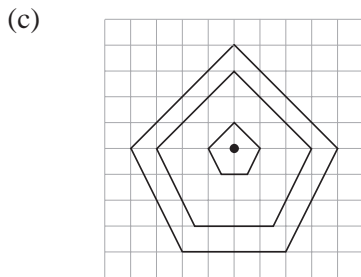
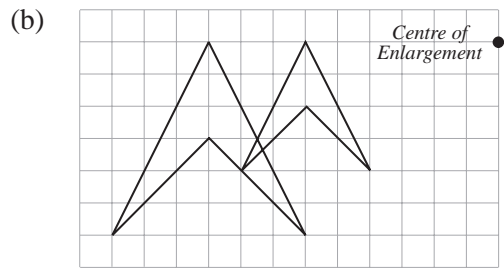
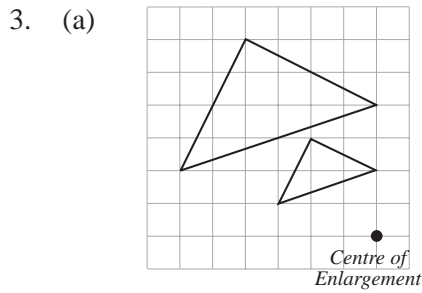

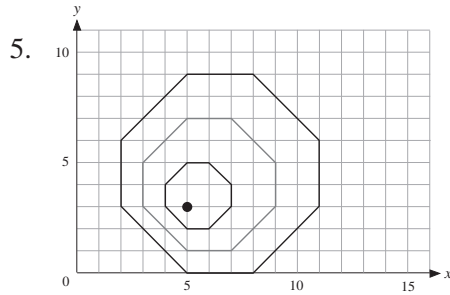

- (c) Scale factor: $\frac{1}{3}$
Centre of enlargement: (5, 3)

6. (a) $\frac{1}{5}$ (b) 6 cm, 9 cm

7. (a) $\frac{2}{3}$; $x = 12$ cm, $y = 8$ cm, $z = 6$ cm (b) $\frac{3}{5}$; $x = 24$ cm, $y = 12$ cm

(c) $\frac{1}{9}$; $x = 7$ cm, $y = 6$ cm, $z = 4$ cm (d) $\frac{3}{8}$; $x = 15$ cm, $y = 18$ cm

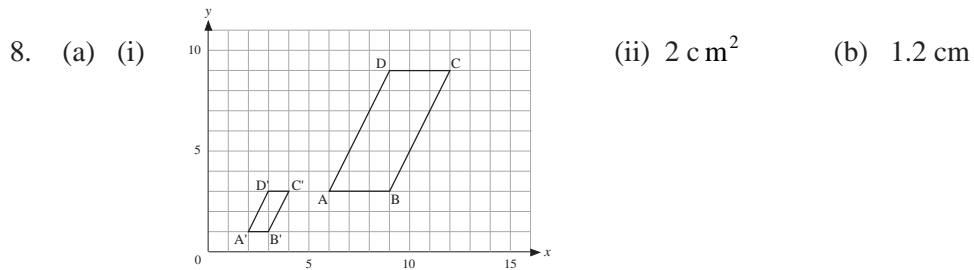

14.8 Further Reflections

1. (a) (b) (c) (d) (e) (f)

2.

| | | | | |
|---|----------|----------|---------|---|
| | E | D | C | B |
| A | $x=10$ | X | $x=6.5$ | X |
| B | $x=11.5$ | X | $x=8$ | |
| C | X | $x=11.5$ | | |
| D | $x=15$ | | | |

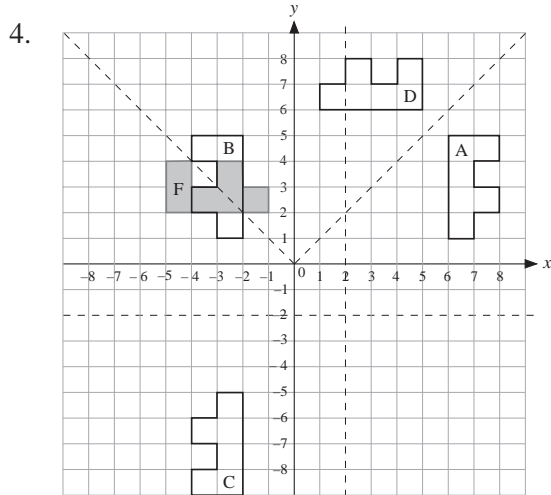
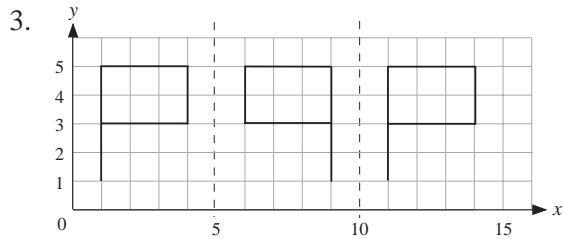

5. (a) $y = x$ (b) $x = 2$ (c) $y = -x$ (d) $y = -x$
 (e) $x = -5.5$ (f) $y = x$ (g) $y = 2$

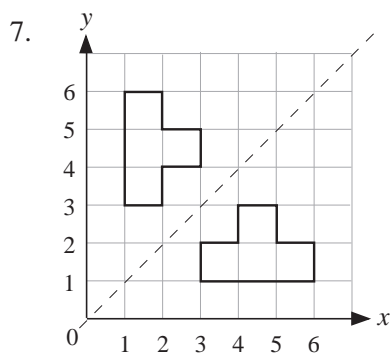
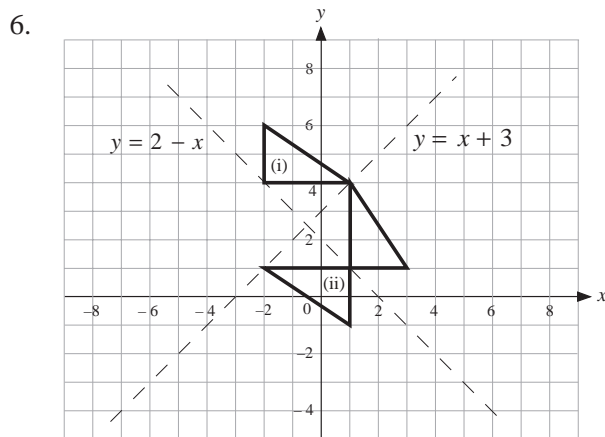

- | | | |
|-----|--------|--------|
| (d) | (3, 1) | (1, 3) |
| | (6, 1) | (1, 6) |
| | (6, 2) | (2, 6) |
| | (5, 2) | (2, 5) |
| | (5, 3) | (3, 5) |
| | (4, 3) | (3, 4) |
| | (4, 2) | (2, 4) |
| | (3, 2) | (2, 3) |

(e) Coordinates interchanged

(f) (2, 3), (2, 5), (3, 3) and (3, 5)

14.9 Rotations

1.

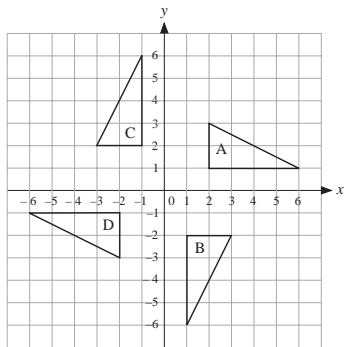

2.

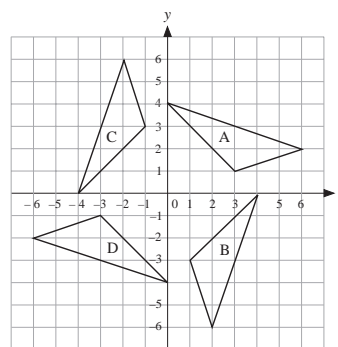

3.

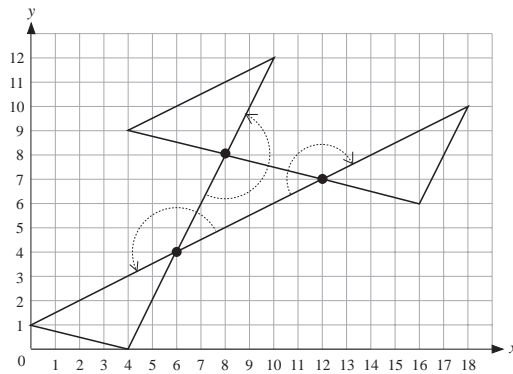

4.

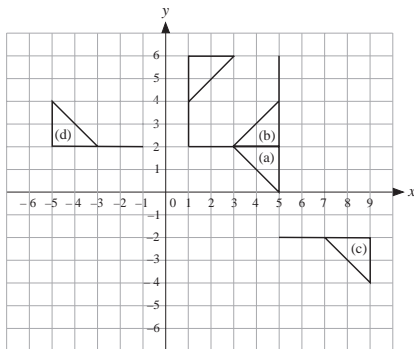

5.

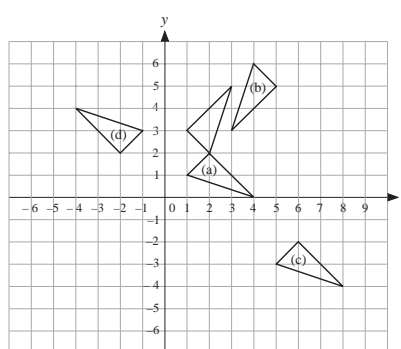

6. (a) A to B: 90° rotation, clockwise, centre (0, 0) (b) A, B and D
 A to C: 180° rotation, centre (0, 0)
 A to D: 90° rotation, anticlockwise, centre (0, 0)
 A to E: 180° rotation, centre (5, 3)
7. A to B: (9, 9)
 A to C: (8, 5)
 A to D: (10, 7)
 A to E: (6, 9)
 A to F: (7, 11)
8. (a) A to B: 180° rotation, centre (5, 7) (b) E and B
 A to C: 180° rotation, centre (0, 4.5)
 A to D: 90° rotation, clockwise, centre (0.5, 3.5)
 A to E: 180° rotation, centre (0, 2)
 A to F: 90° rotation, anticlockwise, centre (-1, 5)

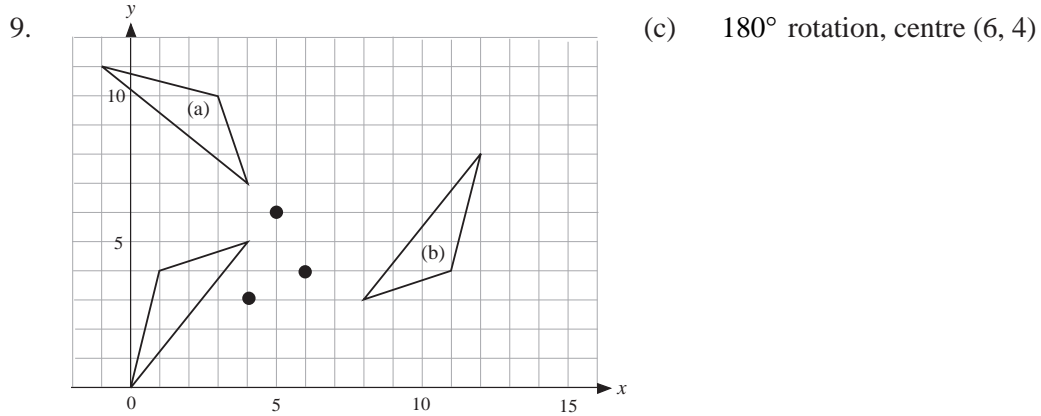

10. 180° rotation, centre (13, 5), followed by 180° rotation, centre (7, 3)

14.10 Translations

1. A: $\begin{pmatrix} 1 \\ 6 \end{pmatrix}$ B: $\begin{pmatrix} 5 \\ 4 \end{pmatrix}$ C: $\begin{pmatrix} 5 \\ -6 \end{pmatrix}$ D: $\begin{pmatrix} 0 \\ -6 \end{pmatrix}$ E: $\begin{pmatrix} -5 \\ -5 \end{pmatrix}$
 F: $\begin{pmatrix} -4 \\ 2 \end{pmatrix}$ G: $\begin{pmatrix} -8 \\ 5 \end{pmatrix}$

2. (a) $\begin{pmatrix} 9 \\ 3 \end{pmatrix}$ (b) $\begin{pmatrix} -5 \\ -1 \end{pmatrix}$ (c) $\begin{pmatrix} -4 \\ -2 \end{pmatrix}$ (d) $\begin{pmatrix} -4 \\ -7 \end{pmatrix}$ (e) $\begin{pmatrix} 4 \\ 7 \end{pmatrix}$
 (f) $\begin{pmatrix} 5 \\ 8 \end{pmatrix}$ (g) $\begin{pmatrix} -9 \\ -8 \end{pmatrix}$ (h) $\begin{pmatrix} 8 \\ -3 \end{pmatrix}$

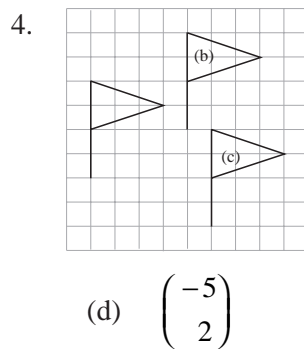
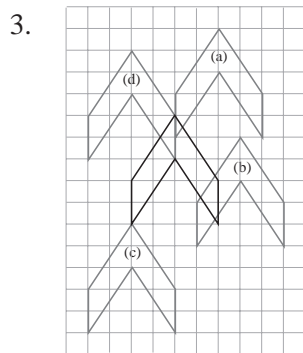

5. (a) $\begin{pmatrix} 8 \\ 0 \end{pmatrix}$

6. 4: A $\rightarrow \begin{pmatrix} 2 \\ -2 \end{pmatrix}$ and $\begin{pmatrix} 3 \\ -2 \end{pmatrix}$ and $\begin{pmatrix} 3 \\ -3 \end{pmatrix}$; B $\rightarrow \begin{pmatrix} 1 \\ -2 \end{pmatrix}$

5: A $\rightarrow \begin{pmatrix} 4 \\ -2 \end{pmatrix}$ and $\begin{pmatrix} 5 \\ -3 \end{pmatrix}$; B $\rightarrow \begin{pmatrix} 3 \\ -1 \end{pmatrix}$ and $\begin{pmatrix} 3 \\ -2 \end{pmatrix}$ and $\begin{pmatrix} 3 \\ -3 \end{pmatrix}$

8. (b) $\begin{pmatrix} 6 \\ 6 \end{pmatrix}$ (c) $\begin{pmatrix} 0 \\ 3 \end{pmatrix}$ (d) $\begin{pmatrix} -2 \\ -6 \end{pmatrix}$

9. (a) $\begin{pmatrix} -2 \\ -13 \end{pmatrix}$ (b) $\begin{pmatrix} 3 \\ 13 \end{pmatrix}$ (c) $\begin{pmatrix} 4 \\ 0 \end{pmatrix}$ (d) $\begin{pmatrix} -4 \\ 0 \end{pmatrix}$

14.11 Combined Transformations

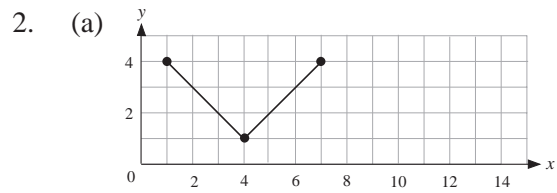
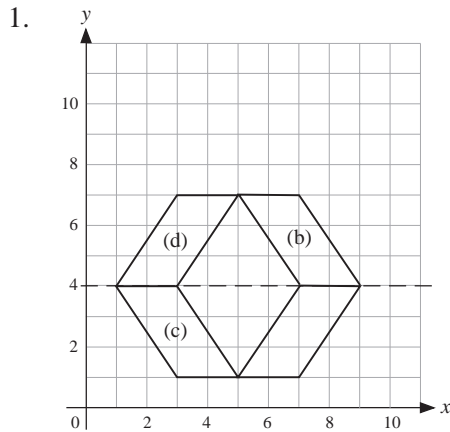

- (b) Reflect in line $x = 7$.
 Rotate 180° about $(7, 4)$ and then reflect in line $y = 4$.

3. (a) Rotations through 90° , 180° and 270° about centre $(2.5, 5.5)$ and rotation of 180° about centre $(1, 4)$.
 (b) Reflection in $y = 4$, $x = 2.5$, $y = x + 3$, $y = 8 - x$.

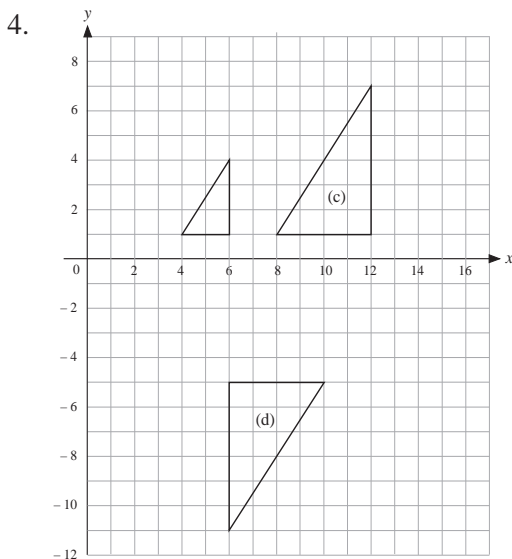

- (e) Rotation of 180° about $(7, -2)$ and enlargement of scale factor $\frac{1}{2}$ about $(6, 1)$

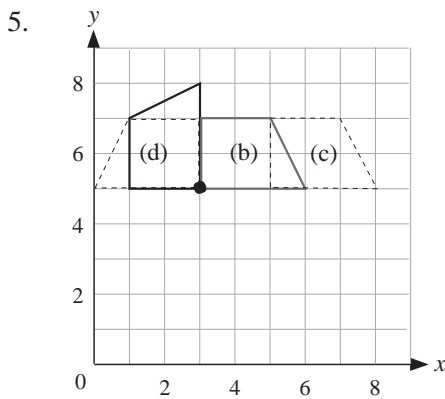

- (e) Reflect in line $y = 8 - x$

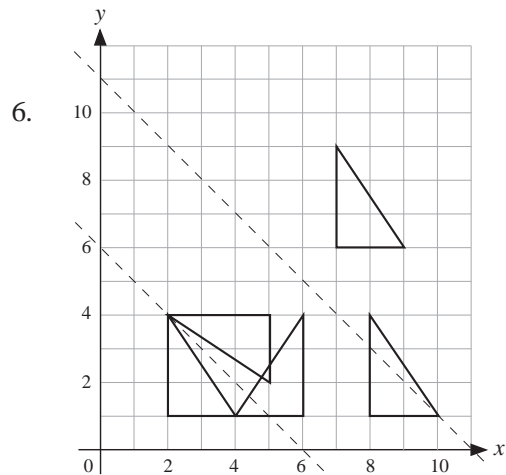

- (c) Translation $\begin{pmatrix} 6 \\ 0 \end{pmatrix}$

- (d) Translation $\begin{pmatrix} 5 \\ 5 \end{pmatrix}$

7. (a) A to B: reflection in $y = x$
 A to C: rotation of 90° clockwise about $(0, 0)$
 A to D: reflection in $y = 0$
- (b) A to E: rotation of 180° about $(0, 0)$, followed by translation $\begin{pmatrix} 0 \\ 1 \end{pmatrix}$
 A to F: reflection in $y = 0$, followed by translation $\begin{pmatrix} -7 \\ 0 \end{pmatrix}$
 A to G: rotation of 90° anticlockwise about $(0, 0)$, followed by translation $\begin{pmatrix} -1 \\ 0 \end{pmatrix}$
 A to H: reflection in $x = 0$, followed by translation $\begin{pmatrix} 0 \\ -1 \end{pmatrix}$

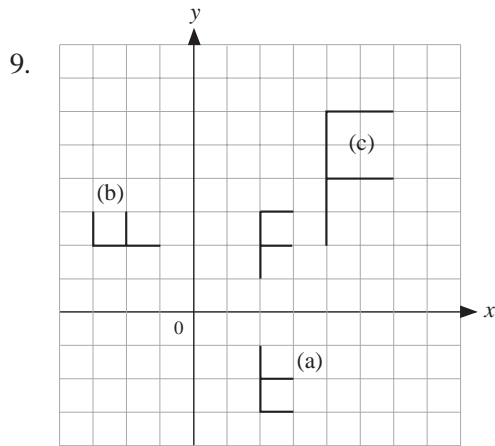

- 10 (a) (i) 90° (ii) $\begin{pmatrix} 0 \\ -4 \end{pmatrix}$ (b) $(2, -2)$
 (c) reflection in line $y = -x$

14.12 Congruence

- ABC and DEF; JKL and GHI; MON and PRQ
- Could be *SSS*, *SAS*, *ASA* or *RHS*
- SAS*
- SAS*
- ABC and AFE; *SAS*
- RHS*

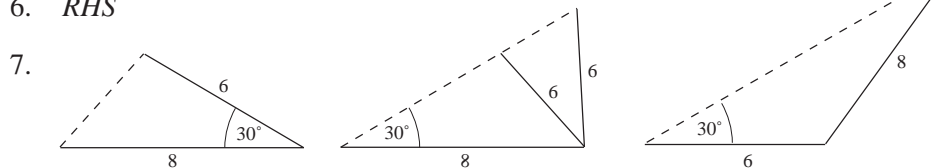

- AXB and CXD; BXC and DXA
- (a) *SSS* (b) *SAS*

14.13 Similarity

1. A and E; C and F, B and D

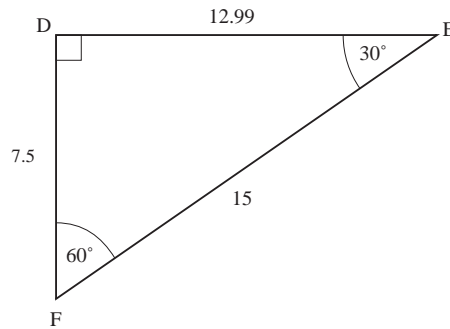
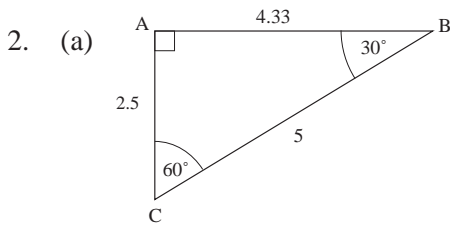

- (b) 1 : 9
3. (a) $AB = 3$ cm, $DH = 4$ cm (b) $AB = 4$ cm, $EH = 3$ cm
4. (a) 1 : 4 (b) 1 : 3
5. (b) (i) 17.5 cm (ii) 10.5 cm (iii) 9 cm (c) (i) 4 : 25 (ii) 4 : 21
6. (b) parallel (c) $x = 10$ cm, $y = 14$ cm (d) 9 : 40
7. (a) 101.25 cm^3 (b) 58.59375 cm^3 (c) 468.75 cm^3
8. (a) 400 cm^3 (b) 4
9. (a) (i) 44% (ii) 72% (b) 14.5%
10. (a) 2 : 3 (b) 4 : 9
11. (a) 12 cm (b) 64 cm^3
12. (a) 63 cm (b) 16.7°
13. (a) 2.5 cm (b) 60° (c) 10.83 cm
14. 280 m
15. (a) 3.44 (b) 40.7° (c) (i) 104.3° (ii) 18 cm
16. (a) (i) APR (ii) $\frac{25}{9}$ m (b) 25.8°
17. (a) 1.63 : 1 (b) 2.08 : 1 (c) Yes – as volume is about half
18. (a) 12 ml (b) 0.9
 (c) *small*: 1.44 ml per penny; *medium*: 1.5 ml per penny; so *medium* is the better offer
 (d) (i) 55 ml (ii) 132.5 ml
19. (a) 81 cm^3 (b) 4.5 cm

14.14 Enlargements with Negative Scale Factors

1. A: 2; B: -1; C: -2; D: -3; E: -1.5; F: $\frac{1}{2}$; G: $-\frac{1}{2}$

2. A: 2, (11, 2); B: -1, (9, 7); C: -1, (5.5, 4); D: -2, (10, 5)

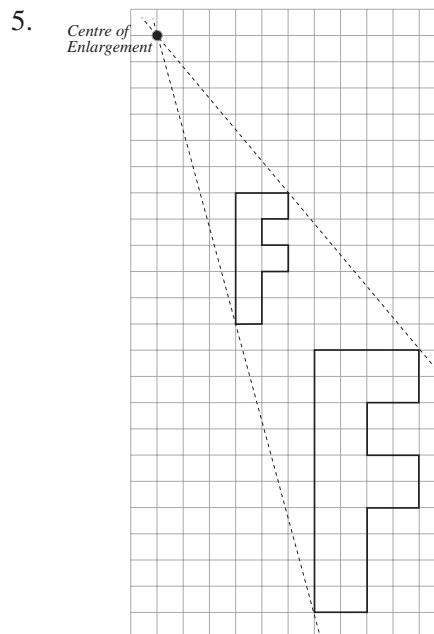
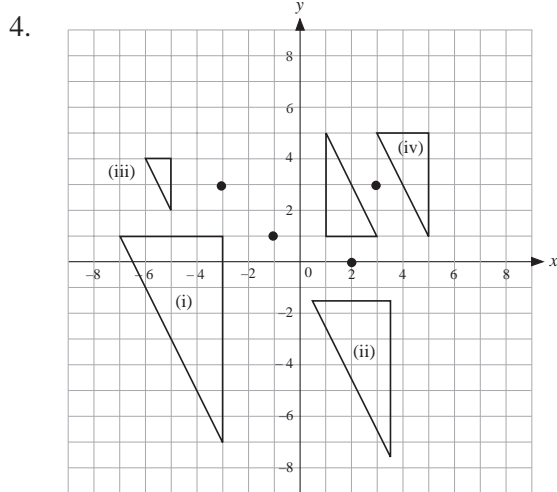
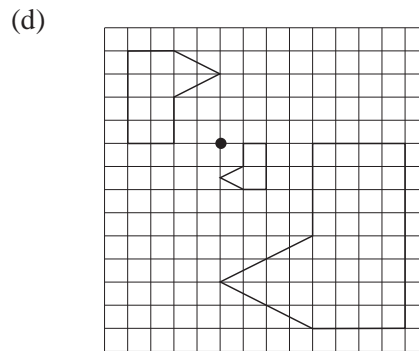
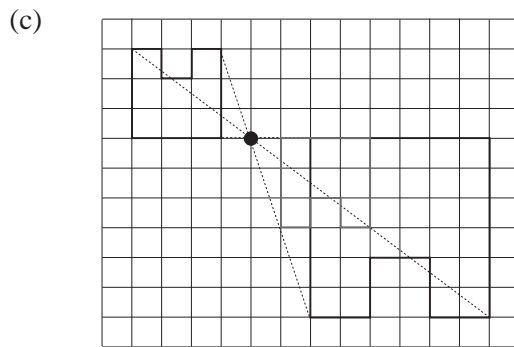
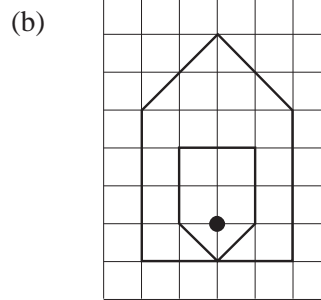
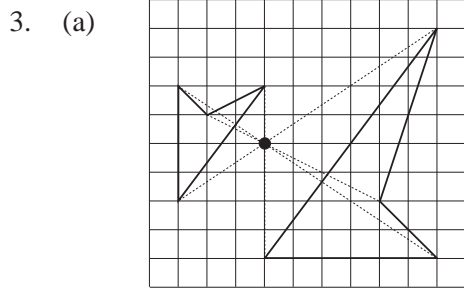

(a) Enlargement, scale factor 2, centre as shown

6. (a)

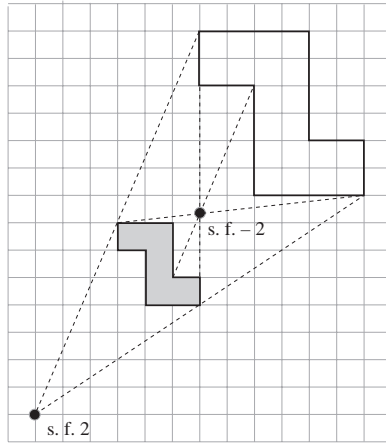

(b)

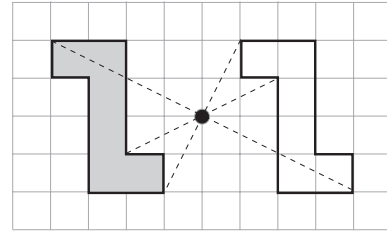

Centre of enlargement as shown, scale factor -1

7. (c) Multiplied by 1, 4 and 9 respectively

(d) Yes for area

8. 3.2 cm

15 Variation

15.1 Simple Ratios

1. (a) 2 : 1 (b) 4 : 1 (c) 1 : 2 (d) 3 : 4 (e) 1 : 6 (f) 4 : 21
 (g) 1 : 6 (h) 1 : 3 (i) 2 : 25 (j) 1 : 8 (k) 4 : 5 (l) 7 : 5
 (m) 27 : 16 (n) 8 : 25 (o) 50 : 49 (p) 4 : 1 (q) 3 : 1 (r) 2 : 7
2. (a) 15 : 16 (b) 16 : 15
3. (a) 10 : 7 (b) 7 : 10
4. (a) 1 : 3 and 1 : 2 (b) Company A
5. (a) 5 : 9 (b) 11 : 18
6. (a) 3 : 2 (b) 1 : 4
7. 3 : 17
8. (a) 9 : 11 (b) 3 : 7 (c) 10 : 9
9. (a) 800 cm³ (b) 160 cm³ (c) 40 cm³
10. 240
11. 24
12. 80
13. 135

15.2 Proportion and Ratio

1. 6 inches
2. (a) 120 gms (b) 160 gms
3. (a) 161 (b) 48
4. (a) 45p (b) £5.75 (c) £9.90
5. (a) 84p (b) £3.40 (c) 24p
6. (a) £2.85 (b) £6.84 (c) £23.94
7. (a) 500 gms (b) 13
8. (a) £23.06 (b) about 16.95 litres
9. (a) 4, 2, 1 (b) $5, \frac{5}{2}, \frac{5}{4}$ (c) $\frac{3}{2}, \frac{3}{4}, \frac{3}{8}$ (teaspoonsful)
10. (a) 5 days (b) 5 days (c) 3 men (2.5)

11. (a) 20 teachers (b) 616 teachers
12. (a) $2\frac{1}{2}$ hours (b) 300 boxes
13. (a) 9 hours (b) 20mins (c) 4
14. Employ 7 people and it takes 2 days
15. £1.45
16. 3, 6, 6, $7\frac{1}{2}$
17. (a) 9 litres (b) (i) 16 (c) (ii) 150
18. 4.5 cm
19. (a) 6 kg (b) 64p
20. Small pot - unit cost = 0.1035p (< 0.1071p)

15.3 Map Scales and Ratios

1. (a) 13.5 km (b) 30 km (c) 16.5 km (d) 11.25 km
2. 234 km, 63.2 km, 84 km, 171.2 km
3. 2.4 km
4. 105 km
5. (a) 1.4 cm (b) 4.2 cm (c) 84 cm
6. 18 km; 30 cm
7. (a) 16.5 km (b) 33 cm
8. (a) 1 : 400 000 (b) 1 : 40 000 (c) 1 : 600 000 (d) 1 : 480 000
9. 1 : 350 000 (a) 1 : 700 000 (b) 1 : 525 000 (c) 1 : 393 750
10. 141 m
11. (a) 1 : 540 000 (b) about 19.5 km
12. 0.1125 km²

15.4 Proportional Division

1. 2 litres of oxygen, 8 litres of nitrogen
2. 18 boys, 45 girls
3. Ben - 80, Emma - 60

15.4

4. (a) £7.05, £5.64 (b) £18.65, £14.92 (c) £13.33, £10.67
5. (a) 500 g, 300 g, (b) 125 g, 75 g (c) 187.5 g, 112.5 g
6. £250, £300, £450
7. £8000, £6000, £4000, £2000
8. Ahmed: 90, Afzal: 150
9. apples: 2kg; bananas: 2.4 kg; oranges: 1.6 kg
10. 50
11. 50 g

15.5 Direct Proportion

1. (a) Yes (b) Yes (c) No (d) Yes
2. (a) $\begin{array}{c|cccc} x & 8 & 10 & 15 & 22 \\ \hline y & 24 & 30 & 45 & 66 \end{array}$ (b) $\begin{array}{c|cccc} p & 5 & 7 & 9 & 11 \\ \hline q & 30 & 42 & 54 & 66 \end{array}$
- (c) $\begin{array}{c|cccc} r & 2 & 3 & 5 & 7 \\ \hline s & 12 & 18 & 30 & 42 \end{array}$ (d) $\begin{array}{c|cccc} w & 4 & 8 & 9 & 12 \\ \hline z & 28 & 56 & 63 & 84 \end{array}$
- (e) $\begin{array}{c|cccc} x & 5 & 6 & 7 & 9 \\ \hline y & 17.5 & 21 & 24.5 & 31.5 \end{array}$ (f) $\begin{array}{c|cccc} t & 3 & 4 & 6 & 9 \\ \hline h & 29.4 & 39.2 & 58.8 & 88.2 \end{array}$
- (g) $\begin{array}{c|cccc} p & 12.6 & 16.8 & 24.5 & 7 \\ \hline q & 19.8 & 26.4 & 38.5 & 77 \end{array}$ (h) $\begin{array}{c|cccc} v & 5 & 12 & 19 & 29 \\ \hline p & 1.80 & 4.32 & 6.84 & 10.44 \end{array}$
3. (a) $C = \frac{500}{3}A$ (b) £4500 (c) 45 m²
4. (a) $F = \frac{5}{2}x$ (b) 10 cm (c) 32.5 N
5. (a) $d = 60\pi n$ (cm) (b) 150.8 m (c) 1061
6. (a) $d = 70t$ miles (t in hours) (b) (i) 140 miles (ii) $\frac{35}{6}$ miles (iii) 84 miles
- (c) (i) 3 hours (ii) 12 mins (iii) $\frac{12}{7}$ mins
7. (a) $c = 2\pi r$, 2π (b) π
8. $z = \frac{42}{5}x$

15.6 Inverse Proportion

1. (a) False (b) True (c) True (d) False
2. (a)

| | | | | |
|-----|----|----|----|----|
| x | 10 | 20 | 25 | 50 |
| y | 10 | 5 | 4 | 2 |

 (b)

| | | | | |
|-----|----|---|----|---------------|
| p | 32 | 8 | 4 | $\frac{1}{2}$ |
| q | 2 | 8 | 16 | 128 |
- (c)

| | | | | |
|-----|----|----|---|-----|
| r | 1 | 3 | 5 | 10 |
| s | 45 | 15 | 9 | 4.5 |

 (d)

| | | | | |
|-----|-----|-----|-----|-----|
| a | 0.9 | 2.4 | 4.8 | 7.2 |
| b | 1.6 | 0.6 | 0.3 | 0.2 |
- (e)

| | | | | |
|-----|------|-----|-----|-----|
| g | 1 | 2 | 9 | 81 |
| h | 16.2 | 8.1 | 1.8 | 0.2 |

 (f)

| | | | | |
|-----|-----|-----|-----|-----|
| u | 2 | 4 | 8 | 17 |
| v | 6.8 | 3.4 | 1.7 | 0.8 |
3. 16
4. (a) $IR = 500$ (b) $\frac{1}{3}$ (c) current is halved
5. (a) halved (b) decreased by a factor of 4 (c) $PV = 800$ (d) 80 Nm^{-2}
6. (a) 3.5 (b) $yx = 28$ (c) x would increase to 14
7. (a) Yes (b) (i) £2400 (ii) 24 years
8. (a) 425 Hz (b) 0.04 m

15.7 Functional and Graphical Representations

1. (a) $T = 40x$ (b) $P = 40v^2$ (c) $R = \frac{216}{x^3}$
- (d) $Y = \frac{72}{x}$ (e) $V = \frac{2500}{x^2}$
2. (a) y is inversely proportional to the fifth power of x
 (b) y is proportional to the square of x
 (c) y is inversely proportional to the square of x
 (d) y is proportional to x
 (e) y is proportional to the cube of x
 (f) y is inversely proportional to x
3. (a)

| | | | | |
|-----|---|----|-----|-----|
| x | 1 | 2 | 5 | 8 |
| y | 4 | 16 | 100 | 256 |

 (b)

| | | | | |
|-----|---|-------|-------|-------|
| x | 1 | 1.1 | 1.2 | 1.3 |
| y | 2 | 2.662 | 3.456 | 4.394 |
- (c)

| | | | | |
|-----|---|------|-----|------|
| x | 1 | 2 | 5 | 10 |
| y | 5 | 1.25 | 0.2 | 0.05 |

 (d)

| | | | | |
|-----|----|---|----------------|----------------|
| x | 1 | 3 | 9 | 12 |
| y | 27 | 1 | $\frac{1}{27}$ | $\frac{1}{64}$ |
4. (a) 768 (b) 4
5. 1
6. (a) $V = 4.2r^3$ (b) 525 cm^3 (c) 12.6 cm

7. (a) $y = \frac{8}{5}x$, $y = \frac{x}{2}$ (b) $y = \frac{1}{x}$, $y = \frac{4}{x}$
 (c) $y = \frac{x^2}{2}$, $y = \frac{x^2}{8}$ (d) $y = \frac{4}{x^2}$, $y = \frac{8}{x^2}$
8. (a) $y = \frac{5}{4}x$ (b) $y = \frac{3}{x}$ (c) $y = \frac{x^2}{4}$ (d) $y = \frac{4}{x^2}$
9. z is proportional to $\frac{1}{x^2}$; $k = 144$
10. (a) multiplied by a factor of 4 (b) increased by $\sqrt{2} \approx 1.41$

15.8 Further Functional Representations

1. (a) $f \propto \frac{1}{\sqrt{v}}$; f is fuel consumption and v is speed
 (b) $r \propto h$; r is rate at which water runs out and h is depth of water
 (c) $r \propto v^{\frac{3}{2}}$; r is air resistance and v is speed
 (d) $P \propto \frac{1}{\sqrt{s}}$; P is period and s is stiffness of spring

2. (a)

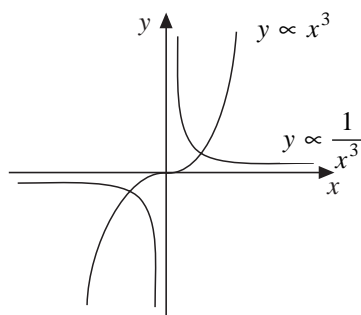

(b)

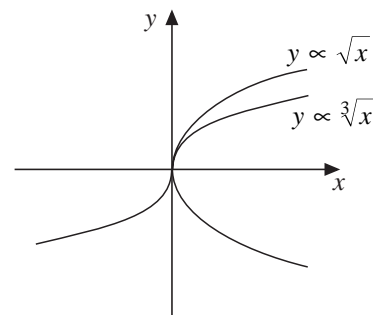

(c)

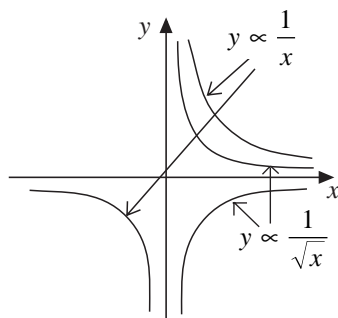

(d)

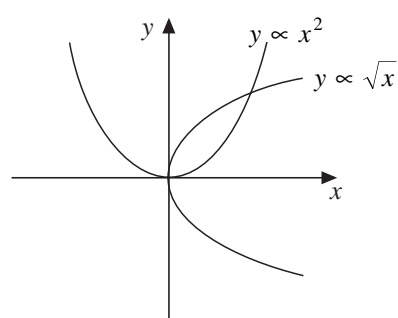

3. (a)

| | | | | |
|-----|---|-----|-----|-----|
| x | 4 | 9 | 100 | 144 |
| y | 1 | 1.5 | 5 | 6 |

(b)

| | | | | |
|-----|-----|---|-----|-----|
| x | 4 | 9 | 25 | 100 |
| y | 1.5 | 1 | 0.6 | 0.3 |

(c)

| | | | | |
|-----|---|---------------|----------------|-----------------|
| x | 1 | 4 | 9 | 49 |
| y | 5 | $\frac{5}{8}$ | $\frac{5}{27}$ | $\frac{5}{343}$ |









(d)

| | | | | |
|-----|----|-----|-----|------|
| x | 9 | 25 | 36 | 81 |
| y | 54 | 250 | 432 | 1458 |





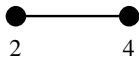
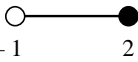
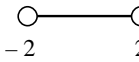
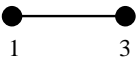
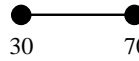
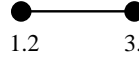

4. (a) 1.47 seconds (b) 556 grams (c) multiplied by $\sqrt{2}$ (≈ 1.41)
(d) multiplied by 4
5. (a) $\frac{1}{3}$ (b) multiplied by 0.794 (c) multiplied by 1.587
6. 1638.4 kg
7. (a) No (b) Yes, $n < 1$ (c) No (d) No (e) Yes, $n < 0$
(f) Yes, $n > 1$
8. (a) $V = \pi r^2 h$ (b) $V \propto \text{height}$ (c) $V \propto (\text{radius})^2$
9. $T \propto \frac{1}{\sqrt{mk}}$
10. (a) 6 (b) -1 (c) $-\frac{3}{2}$
11. $T = 0.2\sqrt{l}$
12. (a) graph (iv) (b) graph (ii) (c) graph (v)

16 Inequalities

16.1 Inequalities on a Number Line

1. (a)  (b)  (c)  (d) 
- (e)  (f)  (g)  (h) 
- (i)  (j)  (k)  (l) 
2. (a) $x < 1$ (b) $x \geq -1$ (c) $x \geq -2$ (d) $-2 \leq x \leq 2$
 (e) $x > -3$ (f) $-2 < x \leq 2$ (g) $-1 < x < 3$ (h) $-1 < x \leq 3$
 (i) $-4 \leq x < 1$ (j) $-5 \leq x < 10$
3. (a)  (b) $30 \leq v \leq 70$
4. (a)  (b) $1.2 \leq x \leq 3.4$
5. (a) 1, 2, 3, 4, 5, 6, 7, 8 (b) 4, 5, 6 (c) 2, 3, 4 (d) 4, 5
6. (a) -1, 0, 1 (b) -5, -4, -3, -2 (c) -1, 0 (d) -4, -3
7. (a) $\frac{3}{4}$, etc (b) $\frac{1}{3}$, etc (c) $\frac{5}{12}$, etc (d) $\frac{1}{4}$, etc
8. -3, -2, -1, 0, 1

16.2 Solution of Linear Inequalities

1. (a) $x \leq -3$  (b) $x > 7$  (c) $x < 5$  (d) $x \geq -2$ 
- (e) $x < 5$  (f) $x \geq \frac{1}{2}$ 
2. (a) $x < 7$ (b) $x \geq -3$ (c) $x \leq 4$ (d) $x \geq \frac{2}{3}$
 (e) $x < \frac{4}{5}$ (f) $x > \frac{6}{7}$ (g) $x \leq 6$ (h) $x > 2$
 (i) $x \leq 4$ (j) $x \geq 3$ (k) $x < 3\frac{1}{5}$ (l) $x \geq 3\frac{1}{3}$

3. (a) $1 < x \leq 3$ (b) $2 \leq x < 5$ (c) $1 \leq x < 5$
 (d) $2 < x < 6$ (e) $-5 \leq x \leq -1\frac{2}{3}$ (f) $-2 < x < 3$
4. (a) $-1 < x \leq \frac{4}{5}$ (b) $2 \leq x \leq \frac{9}{2}$ (c) $\frac{1}{3} < x < \frac{2}{3}$
 (d) $\frac{1}{2} \leq x \leq \frac{15}{8}$ (e) $-1 \leq x \leq -\frac{3}{4}$ (f) $1 < x < 6$
5. (b) $50 \leq 4x - 20 \leq 120$ (c) $18 \leq x \leq 35$
6. (a) $200 \leq m \leq 320$ (b) $200 \leq \frac{5k}{8} \leq 320$ (c) $320 \leq k \leq 512$
7. (a) $50 \leq C \leq 90$ (b) $C = 0.1n + 10$ (c) $400 \leq n \leq 800$
8. $15\frac{5}{9} \leq C \leq 21\frac{1}{9}$
9. (a) $-1, 0, 1, 2$ and 3 (b) 17, 18, 19, 20 or 21
10. (a) (i) $-4, -3, -2, -1, 0$ and 1 (ii) 16 (b) $10 \leq x < 20$

16.3 Inequalities Involving Quadratic Terms

1. (a) $-1 \leq x \leq 1$ (b) $x \geq 2$ or $x \leq -2$ (c) $x \geq 5$ or $x \leq -5$
 (d) $-7 < x < 7$ (e) $x > 6$ or $x < -6$ (f) $x > 2$ or $x < -2$
 (g) $x \geq 2.5$ or $x \leq -2.5$ (h) $-0.5 < x < 0.5$ (i) $x \geq 1.5$ or $x \leq -1.5$
2. (a) $x \geq 4$ or $x \leq -4$ (b) $x \geq 2$ or $x \leq -2$ (c) $-5 < x < 5$
 (d) $-\frac{1}{2} < x < \frac{1}{2}$ (e) $x \geq \frac{2}{3}$ or $x \leq -\frac{2}{3}$ (f) $x \geq \frac{2}{5}$ or $x \leq -\frac{2}{5}$
 (g) $-\frac{1}{3} \leq x \leq \frac{1}{3}$ (h) $-3 < x < 3$ (i) $x \geq 10$ or $x \leq -10$
 (j) $-2 < x < 2$ (k) $x \geq 3$ or $x \leq -3$ (l) $x \geq \frac{1}{2}$ or $x \leq -\frac{1}{2}$
3. (a) $x \geq 2$ or $x \leq -3$ (b) $2 \leq x \leq 5$ (c) $x > 5$ or $x < 0$
 (d) $0 \leq x \leq 6$ (e) $2 < x < 5$ (f) $x > 3$ or $x < -4$
 (g) $x > 1$ or $x < -\frac{1}{2}$ (h) $-2 \leq x \leq \frac{3}{2}$
4. (a) $9 \leq x^2 \leq 16$ (b) $3 \leq x \leq 4$
5. (a) $A = 8x^2$ (b) $2 \leq x \leq 5$ (c) 20 (d) 4
6. (a) $x < 2$ (b) $-1 < x < 1$

16.4 Graphical Approach to Inequalities

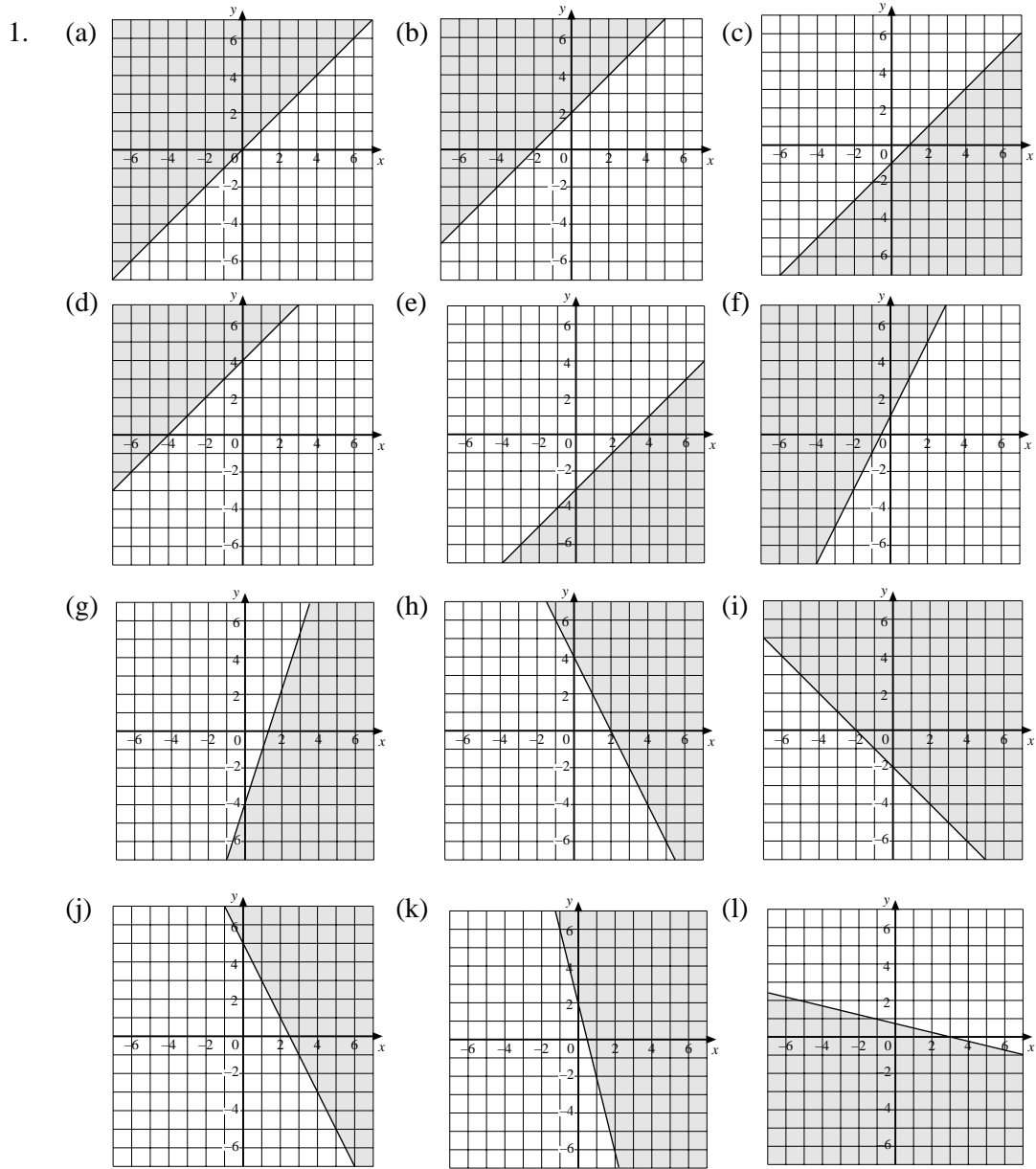

2. (a) (i) $y = x + 1$ (ii) $y \leq x + 1$ (b) (i) $y = 2x$ (ii) $y > 2x$
 (c) (i) $x + y = 5$ (ii) $x + y \leq 5$ (d) (i) $x + y = 4$ (ii) $x + y > 4$
 (e) (i) $y = x + 2$ (ii) $y \geq x + 2$ (f) (i) $y = x - 1$ (ii) $y < x - 1$

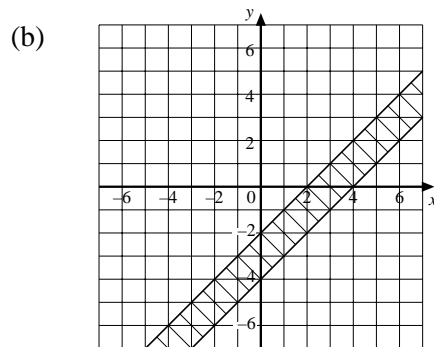
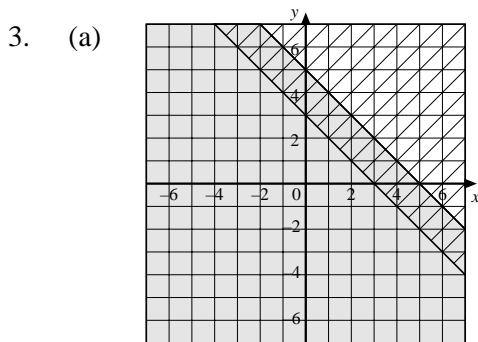

$3 \leq x + y \leq 5$

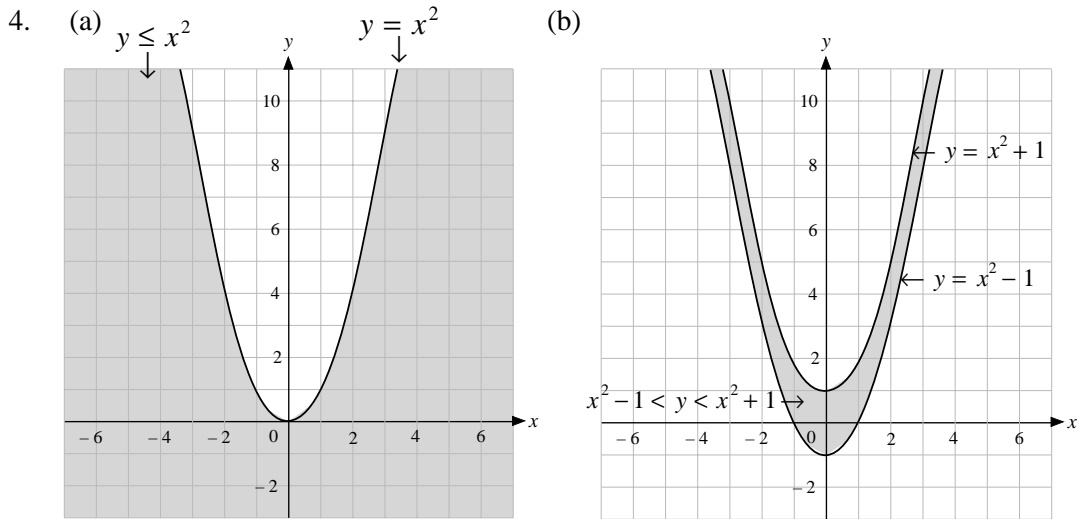

16.5 Dealing With More Than One Inequality

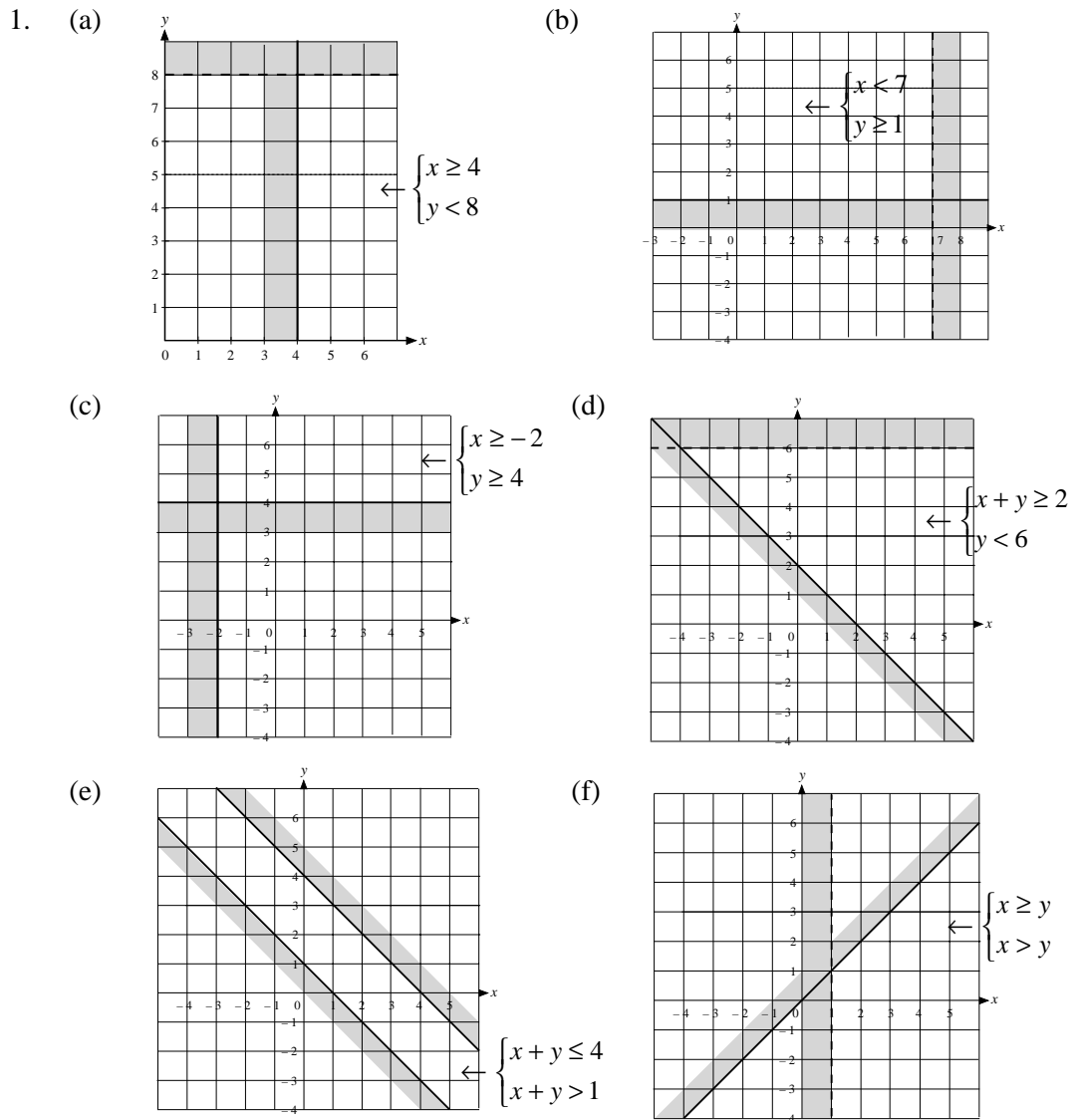

(g)

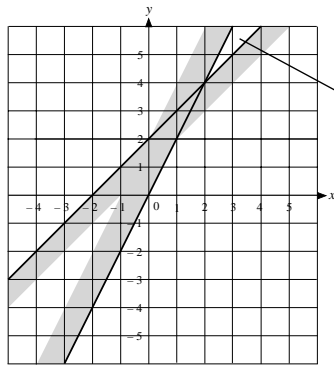

$$\begin{cases} y \leq 2x \\ y \geq x + 2 \end{cases}$$

(h)

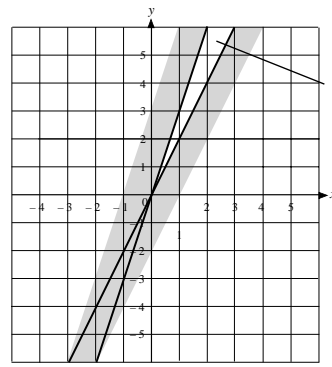

$$\begin{cases} y \leq 2x \\ y \leq 3x \end{cases}$$

(i)

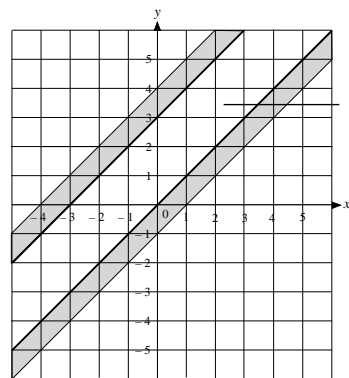

$$\begin{cases} y \geq x \\ y \leq x + 3 \end{cases}$$

2. (a)

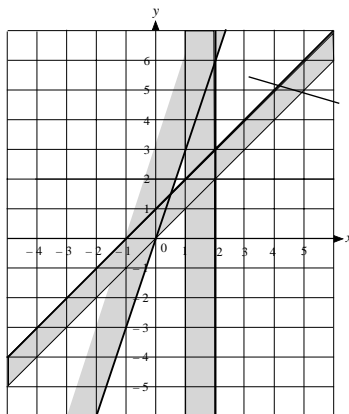

$$\begin{cases} y \geq 2 \\ y \geq x + 1 \\ y \leq 3x \end{cases}$$

Vertices: (2, 3), (2, 6)

(b)

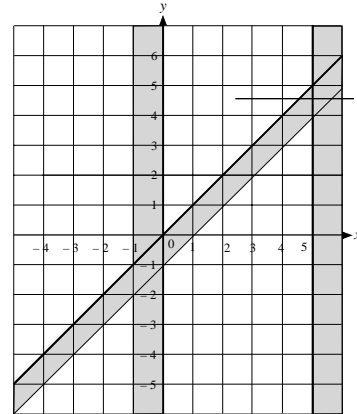

$$\begin{cases} y \geq 0 \\ x \leq 5 \\ y \geq x \end{cases}$$

Vertices: (0, 0), (5, 5)

(c)

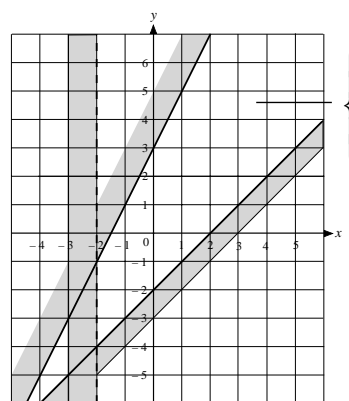

$$\begin{cases} y > -2 \\ y \leq 2x + 3 \\ y \geq x - 2 \end{cases}$$

Vertices: (-2, -4), (-2, -1)

(d)

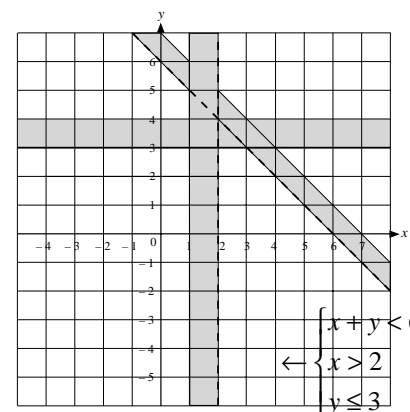

$$\begin{cases} x + y < 6 \\ x > 2 \\ y \leq 3 \end{cases}$$

Vertices: (2, 3), (3, 3)

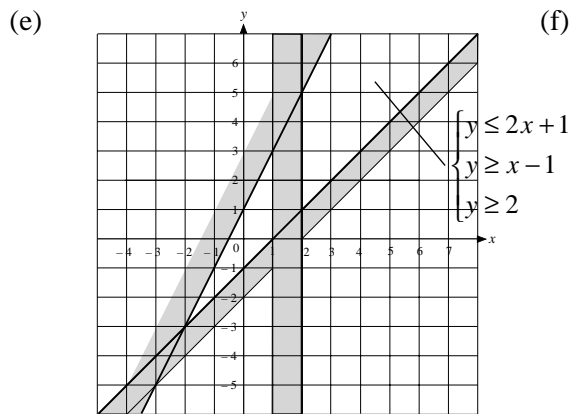

Vertices: (2, 1), (2, 5)

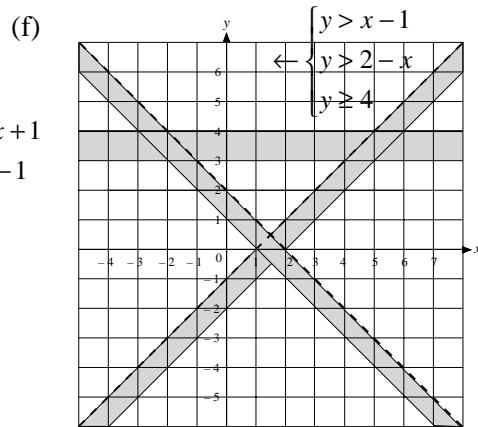

Vertices: (-2, 4), (5, 4)

3. (a) $x \geq 1, y \geq 2, x + y \leq 7$ (b) $x \leq 5, y \geq 2, y \leq x + 2$
 (c) $x \geq 2, y \leq 6, y \geq x - 1$ (d) $x \leq 3, y \geq -3, y \leq x + 1$
 (e) $x \geq -2, y \geq x - 2, y \leq 2 - x$
 (f) $x + y \geq -3, y \geq 2x - 3, 2y \leq x + 3$

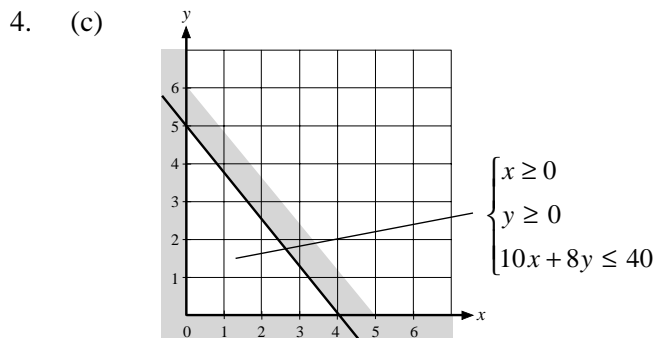

5. (a) (i) $x + y \leq 12$ (ii) $x \geq 2$ (iii) $y \geq 1$

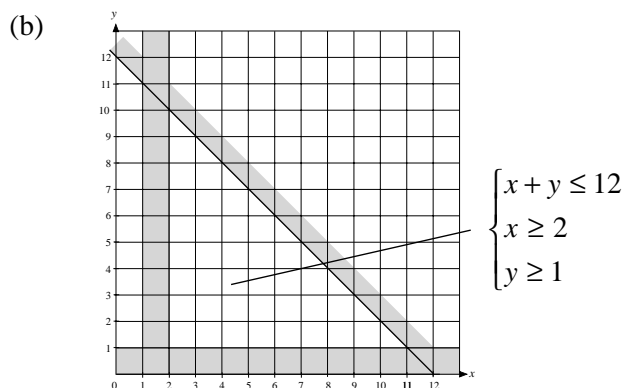

6. (a) (i) $x + y \leq 30$ (ii) $x \leq 20$ (iii) $y \leq 22$ (b) $x \geq 0, y \geq 0$

7. (a) $x + 2y \leq 10$, $x + y \leq 6$, $x \geq 0$, $y \geq 0$

(b)

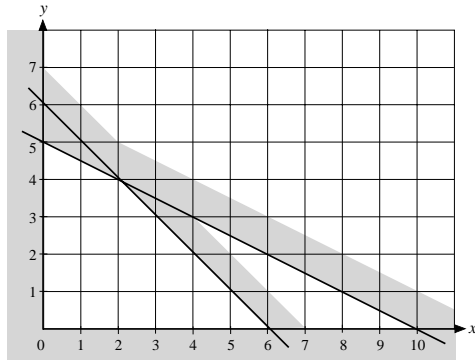

8. (a) (i) 3 (ii) £8 (iii) £5.50 (iv) 15 (b) 3 or 4

9. (b) inner triangle (c) 67 £2 tickets and 133 £3 tickets; £533

10. (a) 3, 4, 5, 6 and 7

(b)

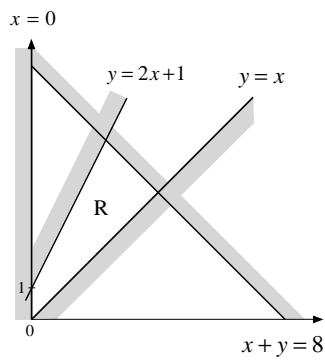

11. (a) $x < 250$, $x + y \leq 300$, $x \geq 2y$ (c) £1000 (d) 120

17 Using Graphs

17.1 Transformations of Graphs

1. A : $y = f(x + 2)$

B : $y = f(x - 3)$

C : $y = f(x - 5)$

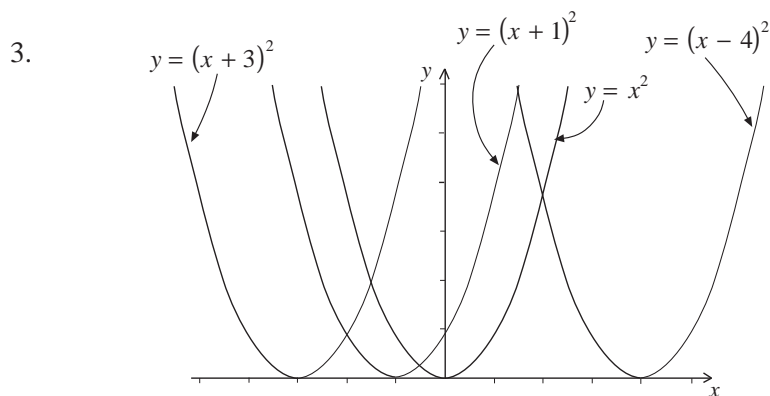
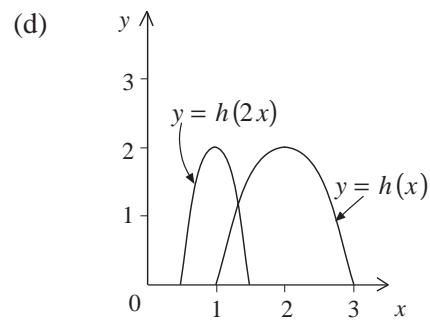
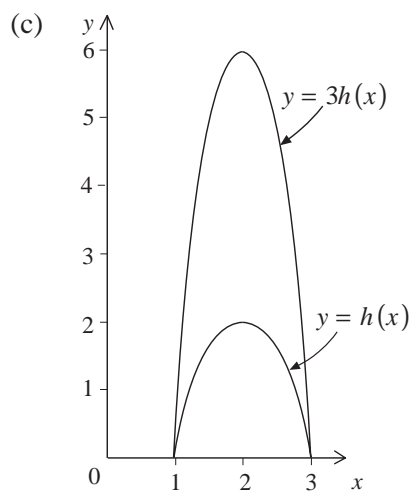
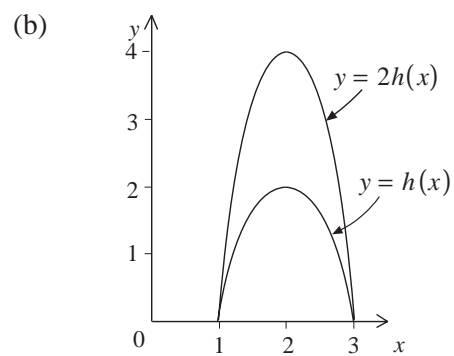
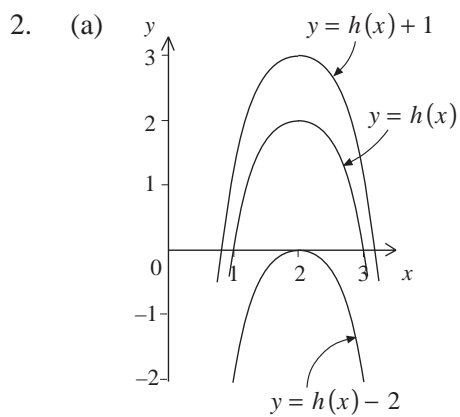

4. (a) Move $x = f(x)$ 2 units along the positive x -axis, and then 2 units up the y -axis.

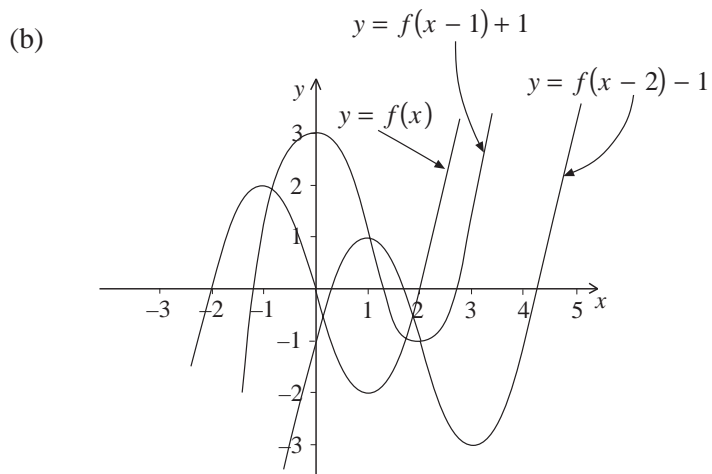

- 5.

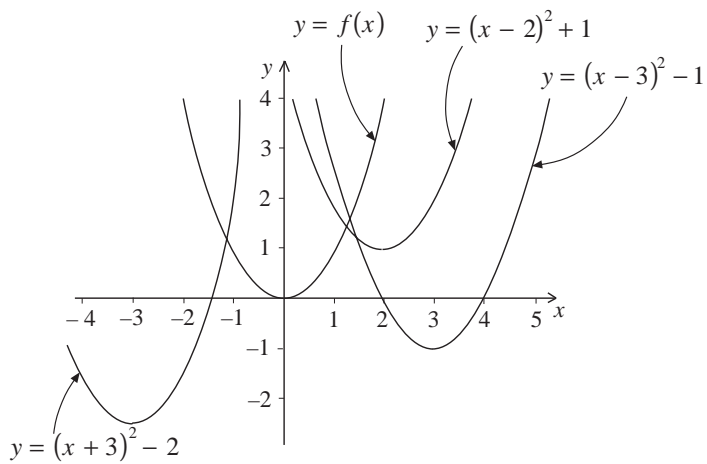

- 6.

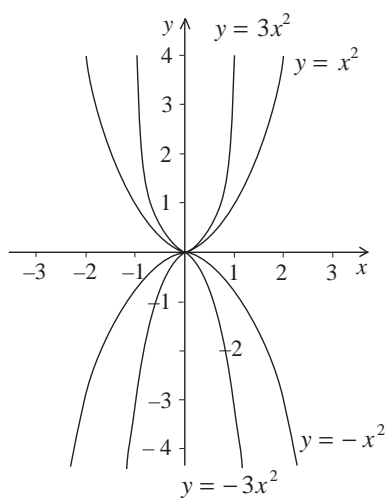

(graphs are reflections of each other)

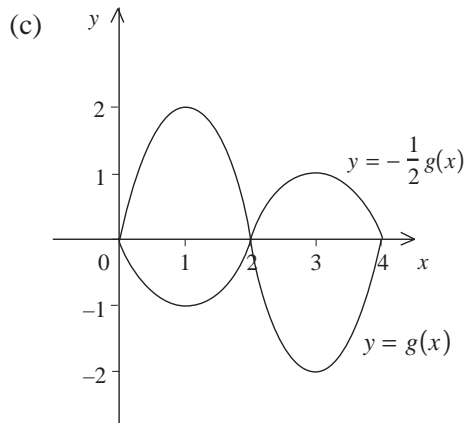
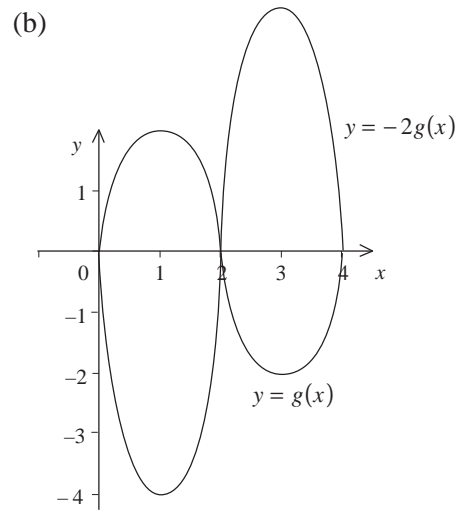
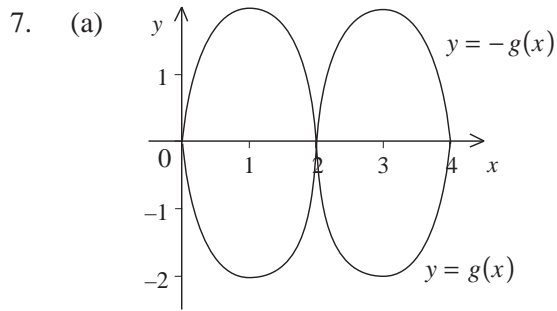

8. (a) $y = f(x)$ and $y = -f(x)$

(b) $y = f(x - 1)$ and $y = -f(x - 1) + 1$

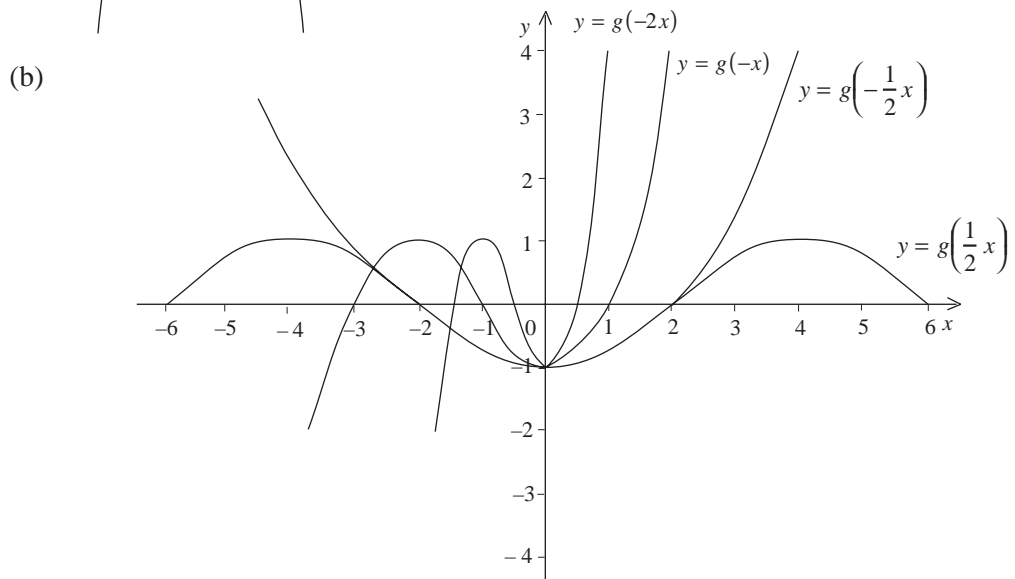
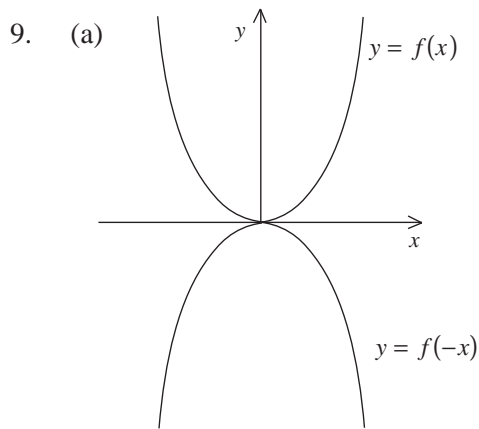

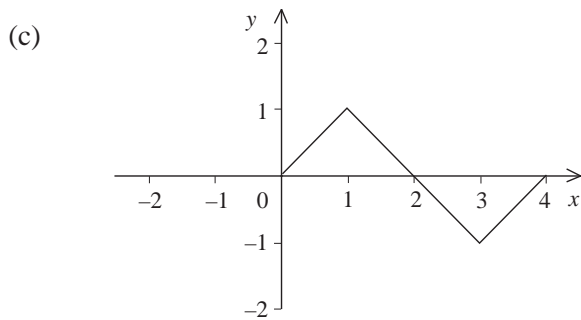
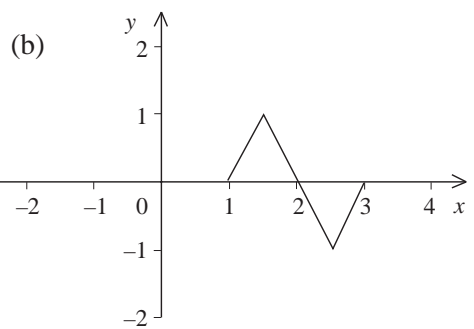
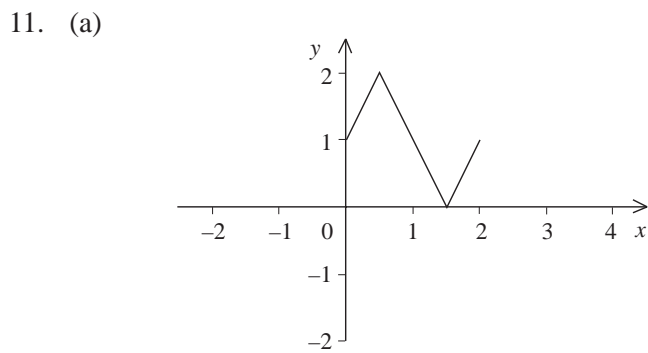
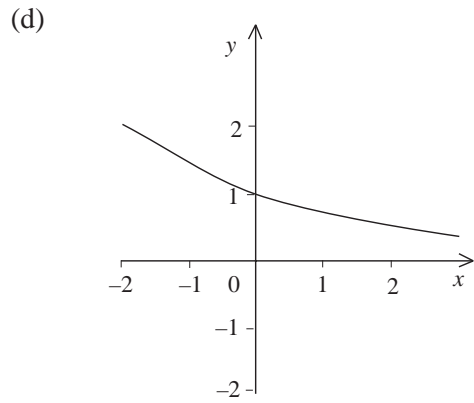
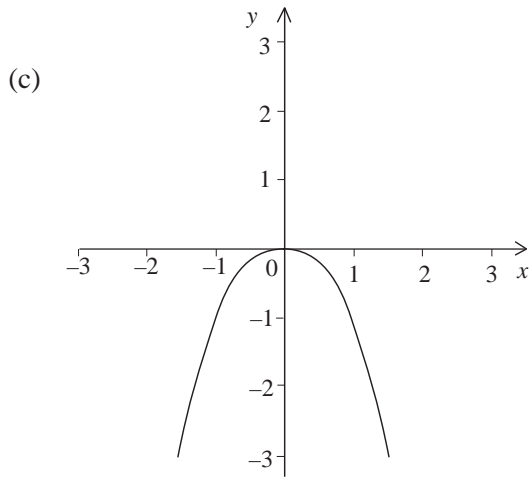
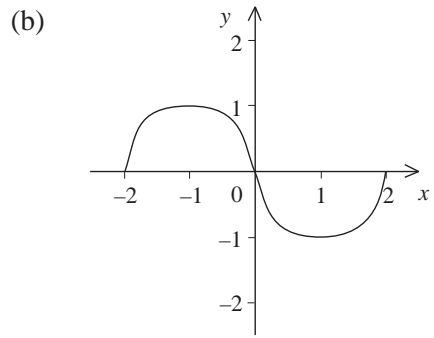
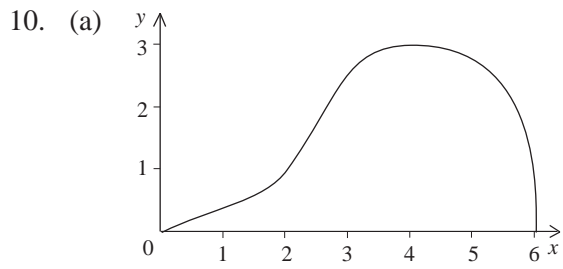

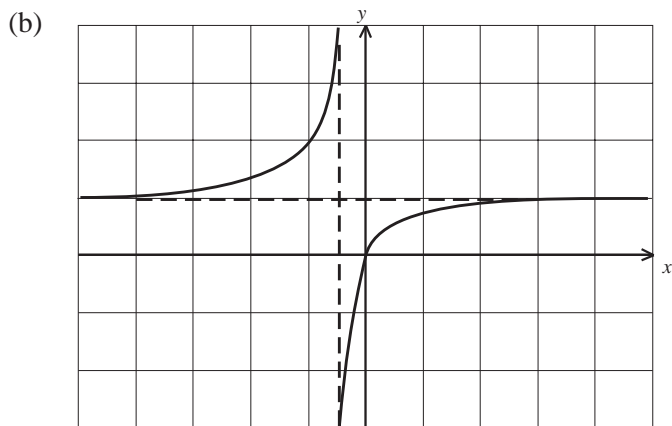
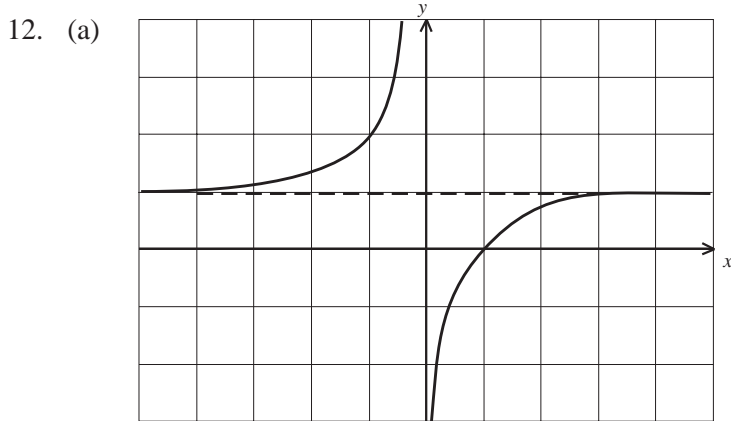

17.2 Areas Under Graphs

1. 16
2. 10
3. (a) 10 (b) $11\frac{3}{8}$
4. (b) about 42 (c) over-estimate
5. 9

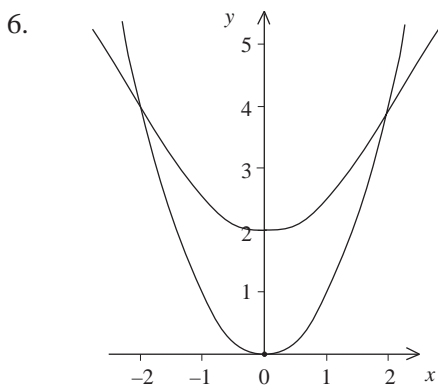

5; this should be a reasonable estimate, but slightly an underestimate

7. 950 m
8. (a) about 15 m^3 (b) about 100 cm^3 (c) about 6250 cm^3
9. (a) (ii) about 1.9 m/s^2 (iii) deceleration (b) about 85 m

17.3 Tangents to Curves

1. (b)

| | | | | | |
|----------|---|---|---|---|---|
| x | 0 | 1 | 2 | 3 | 4 |
| gradient | 0 | 2 | 4 | 6 | 8 |

(c) gradient = $2x$

2. (b) 5, -2 (c) 10

3. (a) $1.8\text{ }^{\circ}\text{C}/\text{min}$ (b) $0.5\text{ }^{\circ}\text{C}/\text{min}$ (c) $0.3\text{ }^{\circ}\text{C}/\text{min}$

4. (b)

| | | | | | |
|----------|----|----|----|----|---|
| t | 0 | 1 | 2 | 3 | 4 |
| gradient | -8 | -6 | -4 | -2 | 0 |

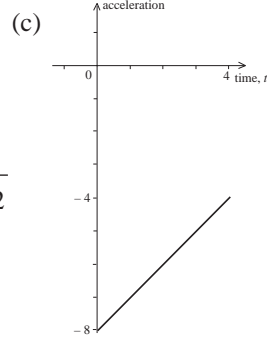

5. (a)

| | | | | | | | | |
|----------|-----|-----|-----|-----|---|------|----|----|
| t | 0 | 1 | 2 | 3 | 4 | 5 | 6 | 7 |
| velocity | 0.5 | 0.8 | 1.6 | 0.8 | 0 | -0.9 | -2 | -2 |

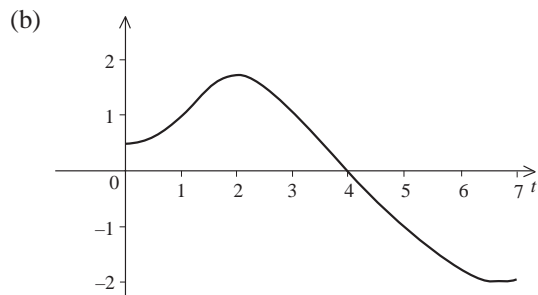

6. (a)

| | | | | | | | |
|----------|----|----|----|---|---|----|----|
| x | -3 | -2 | -1 | 0 | 1 | 2 | 3 |
| gradient | 27 | 12 | 3 | 0 | 3 | 12 | 27 |

(b) gradient = $3x^2$

7. (a) 90° , 270° (b) 1 at $x = 0$, 360° : -1 at $x = 180$

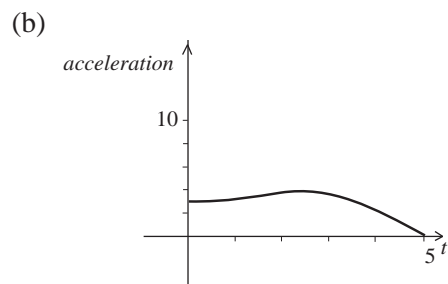
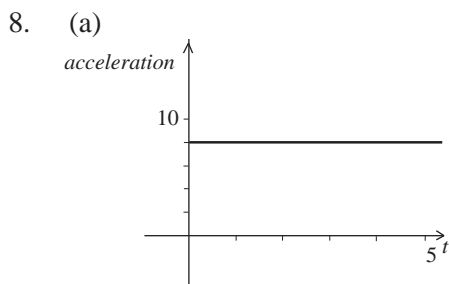
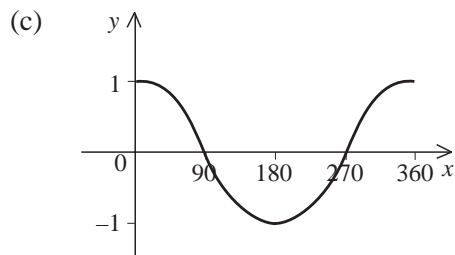

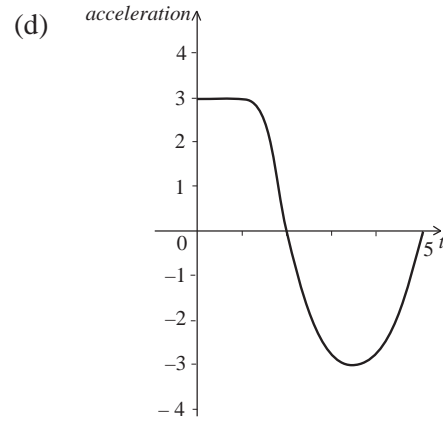
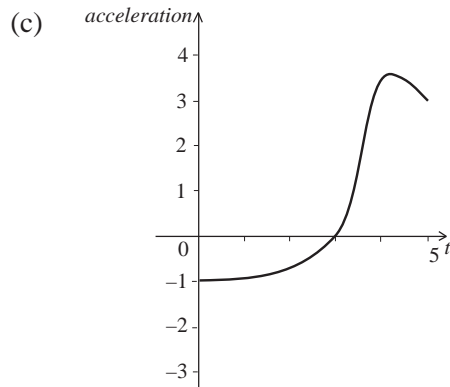

9. 0.6 m/s^2

17.4 Finding Coefficients

1. (a) $a = \frac{1}{2}$, $b = \frac{3}{2}$ (b) $a = 3$, $b = -5$ (c) $a = 15$, $b = 0.25$

(d) $a = 30$, $b = -5$

2. (a) $d = 0.3v$ (b) $d = 0.015v^2$ (c) $d = 0.3v + 0.015v^2$

3. about 0.19

4. about 4.9

5. $R = \frac{10}{I}$

6. Idea probably correct, but data point ($I = 3$, $H = 27.6$) appears to be incorrect.

7. $A = 4$, $B = 5.1$: 8.96

18 3-D Geometry

18.1 Using Pythagoras' Theorem and Trigonometry in Three Dimensions

- (a) 6.7 cm (b) 80.6 cm (c) 55.2 cm
 (d) $\sqrt{3}x$ (e) $\sqrt{6}x$ (f) $\sqrt{x^2 + y^2 + z^2}$
- $\sqrt{56} \approx 7.5$ cm .
- (a) 52.4° (b) 65.5°
- $\sqrt{3} \approx 1.73$ cm
- (a) 4.5 m (b) 2.87 m
- (a) 2.44 m (b) $d = \sqrt{h^2 + \left(l^2 + \frac{w^2}{4}\right)}$
- (a) 29.7 m (b) 31.1°
- 15.6 cm
- (a) 10.6 cm (b) 28.1° ; (a) 11.1 cm (b) 22.6°
- (a) 4.9 cm (b) 56.3° (c) 64.6°

18.2 Angles and Planes

- (a) 25.4° (b) 26.6° (c) 18.4°
 (d) 16.6° (e) 16.6° (f) 67.4°
- (a) 1.66 cm (b) 10.99 cm
- (a) 23.4° (b) 22.8° (c) 77.1°
- (a) 36.9° (b) 22.6° (c) 36.9° (d) 71.6°
- (a) 10.4 cm (b) 74.2° (c) 78.7°
- 76° , 80.5°
- (a) 29° (b) 29° (c) 43.3° (d) 61°
- 77.8° , 76°
- 64.8° , 71.6°
- 2 m

19 Vectors

19.1 Vectors and Scalars

1. Vectors: (b), (d), (e) scalars: (a), (c), (f)

2. (a) $\begin{pmatrix} 6 \\ 0 \end{pmatrix}$ (b) $\begin{pmatrix} 6 \\ -3 \end{pmatrix}$ (c) $\begin{pmatrix} -3 \\ 2 \end{pmatrix}$ (d) $\begin{pmatrix} -6 \\ -3 \end{pmatrix}$

(e) $\begin{pmatrix} 6 \\ 3 \end{pmatrix}$ (f) $\begin{pmatrix} 3 \\ -5 \end{pmatrix}$ (g) $\begin{pmatrix} -3 \\ -2 \end{pmatrix}$ (h) $\begin{pmatrix} 3 \\ 2 \end{pmatrix}$

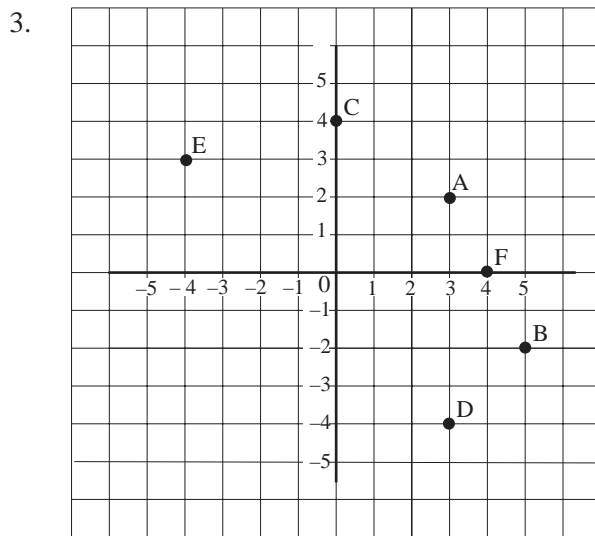

$$EF = \begin{pmatrix} 8 \\ -3 \end{pmatrix}$$

4. (a) $\begin{pmatrix} 7 \\ 2 \end{pmatrix}$ (b) $\begin{pmatrix} 3 \\ -1 \end{pmatrix}$ (c) $\begin{pmatrix} 4 \\ 11 \end{pmatrix}$ (d) $\begin{pmatrix} 1 \\ 12 \end{pmatrix}$

(e) $\begin{pmatrix} -1 \\ -12 \end{pmatrix}$ (f) $\begin{pmatrix} -4 \\ -3 \end{pmatrix}$ (g) $\begin{pmatrix} 12 \\ 21 \end{pmatrix}$ (h) $\begin{pmatrix} -6 \\ 10 \end{pmatrix}$

(i) $\begin{pmatrix} 0 \\ 16 \end{pmatrix}$ (j) $\begin{pmatrix} 17 \\ -1 \end{pmatrix}$ (k) $\begin{pmatrix} -12 \\ -1 \end{pmatrix}$ (l) $\begin{pmatrix} 12 \\ -28 \end{pmatrix}$

5. (a) $\begin{pmatrix} 10 \\ 1 \end{pmatrix}$ (b) $\begin{pmatrix} 2 \\ -8 \end{pmatrix}$ (c) $\begin{pmatrix} 0 \\ 9 \end{pmatrix}$ (d) $\begin{pmatrix} -4 \\ -14 \end{pmatrix}$

(e) $\begin{pmatrix} -10 \\ -14 \end{pmatrix}$ (f) $\begin{pmatrix} 24 \\ 21 \end{pmatrix}$

6. (a) $\begin{pmatrix} 1 \\ -3 \end{pmatrix}$ (b) $\begin{pmatrix} 6 \\ -2 \end{pmatrix}$ (c) $\begin{pmatrix} 1 \\ -1 \end{pmatrix}$ (d) $\begin{pmatrix} \frac{1}{2} \\ \frac{3}{-2} \end{pmatrix}$ (e) $\begin{pmatrix} -1 \\ -3 \end{pmatrix}$

(f) $\begin{pmatrix} 4 \\ 7 \end{pmatrix}$ (g) $\begin{pmatrix} 3 \\ -\frac{11}{2} \end{pmatrix}$ (h) $\begin{pmatrix} -7 \\ \frac{13}{2} \end{pmatrix}$ (i) $\begin{pmatrix} -5 \\ 3 \end{pmatrix}$

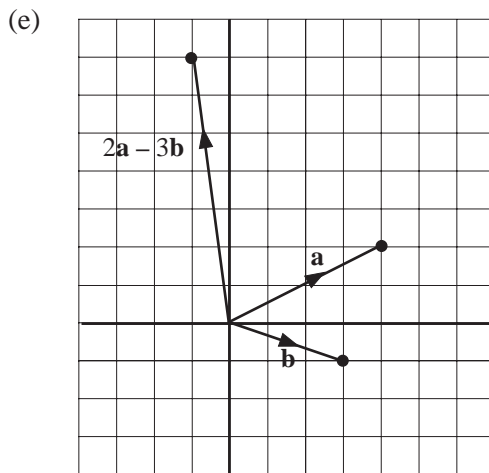
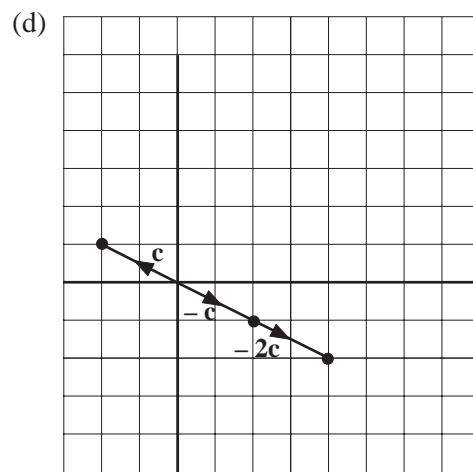
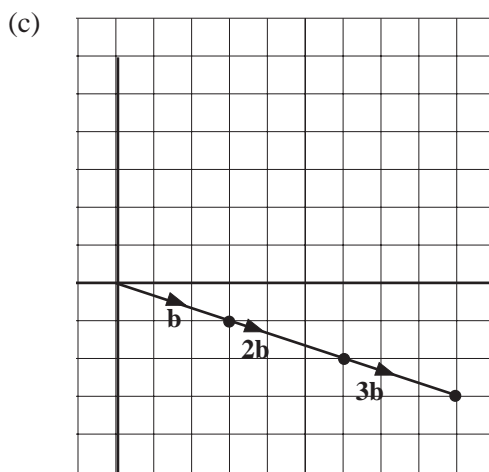
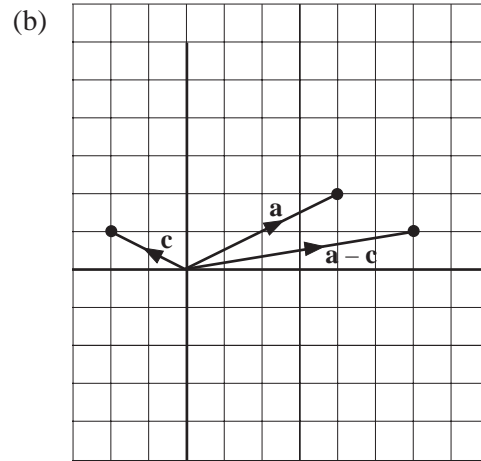
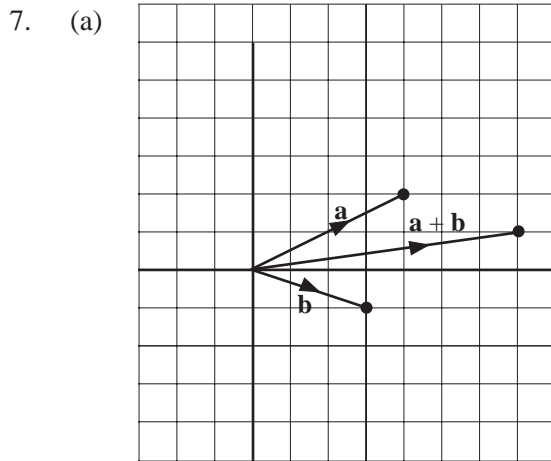

19.2 Applications of Vectors

- (a) 3.4 m/s, 63° (b) $3\frac{1}{3}$ s (c) 5 m
- 2.5 m/s, 1.875 m/s
- (a) 34 m/s (b) 081° , 62.5 m/s
- 37° to bank; 20 s
- (a) bearing 343° , speed 209 km/h (b) bearing 017.5°

6. 408 seconds
 7. (b) $P = 577 \text{ N}$, $Q = 289 \text{ N}$
 8. $R = 580 \text{ N}$, $F = 155 \text{ N}$
 9. 0.64 m/s
 10. 93.75 m
 11. (a) (i) 0.85 m/s (ii) 28° (b) (i) 8 m (ii) 20 s

19.3 Vectors and Geometry

1. (a) $4\mathbf{a}$ (b) \mathbf{a} (c) \mathbf{b} (d) $-\mathbf{a} + 2\mathbf{b}$
 (e) \mathbf{b} (f) $3\mathbf{a} + 2\mathbf{b}$ (g) $3\mathbf{b}$ (h) $3\mathbf{b}$
 (i) $\mathbf{a} - \mathbf{b}$ (j) $2\mathbf{a} - 2\mathbf{b}$ (k) $-\mathbf{a} - 2\mathbf{b}$ (l) $-3\mathbf{a} - 2\mathbf{b}$
 (m) $-3\mathbf{a} + 3\mathbf{b}$ (n) $-2\mathbf{a}$ (o) $-4\mathbf{a} + \mathbf{b}$ (p) $-3\mathbf{a} - 3\mathbf{b}$

2.

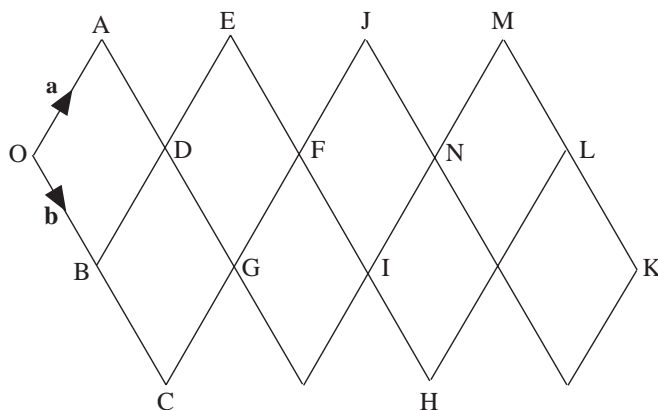

3. (a) (i) \mathbf{c} (ii) \mathbf{a} (iii) $-\mathbf{a}$ (iv) $-\mathbf{a} + \mathbf{c}$ (v) $\mathbf{a} + \mathbf{c}$ (vi) $\mathbf{a} - \mathbf{c}$
 (b) (i) $\frac{1}{2}\mathbf{c}$ (ii) $\mathbf{a} + \frac{1}{2}\mathbf{c}$ (iii) $\frac{1}{2}\mathbf{a}$ (iv) $\mathbf{c} + \frac{1}{2}\mathbf{a}$ (v) $-\frac{1}{2}\mathbf{a} + \frac{1}{2}\mathbf{c}$
4. (a) $\frac{1}{2}(\mathbf{q} + \mathbf{p})$ (b) $\frac{1}{2}(\mathbf{p} + \mathbf{q})$ (c) M and N are coincident
5. (a) $\vec{AD} = 6\mathbf{i}$, $\vec{OD} = 6\mathbf{i} + 6\mathbf{j}$
 (b) $\vec{CE} = 4\mathbf{j}$, $\vec{OE} = 8\mathbf{i} + 4\mathbf{j}$
 (c) $\vec{OM} = 7\mathbf{i} + 5\mathbf{j}$
6. (a) $\frac{1}{2}(\mathbf{p} + \mathbf{q})$, $\frac{1}{2}\mathbf{p} + \frac{5}{2}\mathbf{q}$ (b) $2\mathbf{q}$
8. (a) $2\mathbf{a} + \mathbf{b} + \mathbf{c}$ (b) $\mathbf{a} + \frac{1}{2}\mathbf{b} + \frac{1}{2}\mathbf{c}$ (c) $-\mathbf{a}$ (d) $\mathbf{a} + \frac{1}{2}\mathbf{b} - \frac{1}{2}\mathbf{c}$
 (e) $\frac{1}{2}(\mathbf{c} - \mathbf{b})$

10. (a) $\frac{1}{3}\mathbf{b} - \mathbf{d}$ (b) $\mathbf{b} + \mathbf{d}$ (c) $\alpha = \beta = 3$

11. $\vec{AQ} = \frac{1}{3}(\mathbf{a} + \mathbf{b})$

12. (a) $\vec{AC} = 2\mathbf{p} + 8\mathbf{q}$

13. (a) (i) $-\mathbf{a} + \frac{1}{2}\mathbf{c}$ (ii) $\mathbf{c} - 2\mathbf{a}$ (b) 1 : 2

19.4 Further Work with Vectors

1. (a) $\begin{pmatrix} 40 \cos 20^\circ \\ 40 \sin 20^\circ \end{pmatrix}$ (b) $\begin{pmatrix} 30 \cos 80^\circ \\ 30 \sin 80^\circ \end{pmatrix}$ (c) $\begin{pmatrix} 8 \cos 30^\circ \\ 8 \sin 30^\circ \end{pmatrix}$

(d) $\begin{pmatrix} 7 \cos 20^\circ \\ -7 \sin 20^\circ \end{pmatrix}$ (e) $\begin{pmatrix} -12 \cos 40^\circ \\ 12 \sin 40^\circ \end{pmatrix}$ (f) $\begin{pmatrix} -10 \cos 38^\circ \\ -10 \sin 38^\circ \end{pmatrix}$

2. (a)

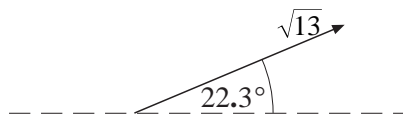

(b)

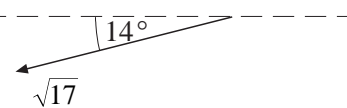

(c)

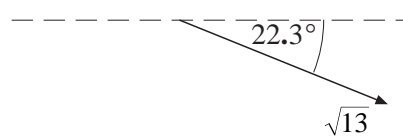

(d)

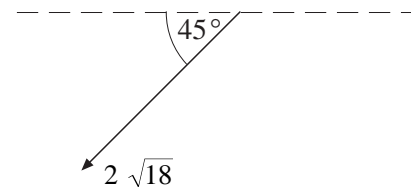

(e)

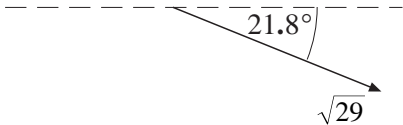

(f)



3. $\begin{pmatrix} 5 \\ -3 \end{pmatrix}, \sqrt{34}$

4.

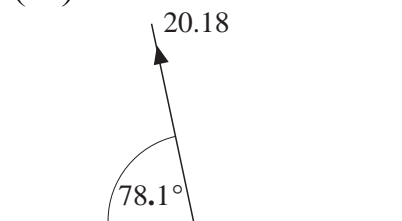

5. $\begin{pmatrix} 3 \\ -1.2 \end{pmatrix}, 3.23 \text{ m/s at } 111.8^\circ$

6. 242 m/s, 221.4°
7. 226.4 m/s at 169.2°
8. $F \approx 7.21$ N, $\theta \approx 43.9^\circ$
9. $\theta \approx 23.6^\circ$, 80.9 N
10. $\theta \approx 59.3^\circ$, 386.5 N
11. (a) (i) $2 \cos a$ (ii) $1 - 2 \sin \alpha$ (b) 30°

19.5 Commutative and Associative Properties

1. $\mathbf{a} - \mathbf{b} = \begin{pmatrix} -1 \\ 3 \end{pmatrix}$, $\mathbf{b} - \mathbf{a} = \begin{pmatrix} 1 \\ -3 \end{pmatrix}$, $\mathbf{a} - \mathbf{b} \neq \mathbf{b} - \mathbf{a}$
5. $(\mathbf{a} + \mathbf{b}) + \mathbf{c} = \begin{pmatrix} 6 \\ 1 \end{pmatrix} = \mathbf{a} + (\mathbf{b} + \mathbf{c})$

20 Answers

20.1 Data Collection

1. (a) No, since $p(4 \text{ Heads}) = \frac{1}{2^4} = 0.0625 (>0.05)$
 (b) Yes, since $p(5 \text{ Heads}) = \frac{1}{2^5} = 0.03125 (<0.05)$
2. Discrete, Continuous, Discrete
3. (a) No. of wheels, etc. (b) Its weight, etc.
4. (a) Undertake a survey (b) Secondary data (c) May not be reliable
5. (a) Sample too small; samples may not be independent of each other
 (b) Easier and cheaper
6. Too small a sample, and not representative (as they are in the same family).
7. Nobody under age 18 interviewed; too many males (particularly in the 26-40, 41-64 age groups)
8. You would need a large sample to have proof!
 Indeed, for proof, you would need to survey all women.
9. (a) 600 (b) (i) 72% (ii) 88%
 (c) The problem is not the sample size, but the large number of non-respondents.
 (d) Undertake interviews (either face to face or by telephone).
10. (a) (i) Label 001 to 500 all pupils, and take random digits, three at a time, ignoring those over 500 or repeats.
 (ii) Choose a number between 01 and 50 at random, say x ; then choose $x, x + 50, x + 100, \dots x + 450$ as the sample.
 (b) (i) BOY/GIRL or by age groups
 (ii) You are more likely to get a representative sample.
11. (a) 220 (b) 180 (c) 180, since it comes from a larger sample
 (d) You would need to add a species of fish not present at the moment and then apply the same techniques.
12. (a) Find the number of woodlice in similar areas of the garden, but some areas being damp and others not.
 (b) Survey no. of woodlice in dark, damp conditions and in light damp conditions.
13. (a) Method 2 would include pupils from all year groups.
 (b) Method 1 would only sample pupils who arrive early.
 Method 3 might not have enough pupils from some year groups.
 (c) Question is posed in a negative way.
 (d) e.g. "Do you think that school uniform should be worn?"

14. (a) (i) Discrete (ii) Qualitative (iii) Continuous (iv) Qualitative
(b) (i) (i) and (iii) (ii) (ii) and (iv)
(c) Scatter plot (d) Height and weight
15. (a) Only people travelling by train would be sampled.
Sample would consist mainly of commuters on their way home - not representative.
'First 100' is not a representative sample.
(b) Use electoral register as sampling frame, and choose sample randomly.
(c) (i) It is not possible to test the lifetime of all batteries.
(ii) Too expensive to take a census
(iii) Check for quality control at regular intervals.
16. (a) e.g. "How long do you think the interval should last?"
(b) Provide a stamped, addressed envelope; offer an incentive such as reduction in price of a ticket to those who reply.
(c) All ticket holders numbered, and 20 chosen (without replacement) at random.
(d) (i) Choose one of the numbers 1 - 5 at random, and then every 5th person after that.
(ii) $\frac{1}{5}$
(e) 8
(f) Random sampling, as it will not necessarily be representative.
17. (a) Temperature (as this could explain the difference in times)
(b) Typing times (as these are potentially dependent on temperature)
(c) Roughly equal numbers and similar typing skills in each group.
18. (a) Pupils of different gender will have different spending patterns.
(b) (i) Different spending patterns.
(ii) Number all boys in sampling frame, and choose 20 at random.

20.2 Presentation of Data

1. (a) 40 (b) 30 (c) 180 (d) 9 (e) £7500
2. (a) about 260 (b) about 10 000 (c) they need less
3. (a) 1 800 000 (b) UK (c) 200 000
(d) Far fewer teachers in Somalia than in Vietnam.
4. (a) 29 (b) 6 (c) 6
5. (a) 370 000 (million) (b) 15 days (c) very large population

6. (a) £8562
 (b) Each disc for Fairplan is worth £7132, which is far less than £8562.
7. (a) 6 (b) 36 (c) 120 (d) 15%, 25%, 10%, 30%, 5%, 15%
8. (a) 65 - 70 (b) (i) 10-15 (ii) about 14% (c) about 6.5%
 (d) e.g. In India, very few people live to over 70; in UK, significantly more females than males live beyond 70.

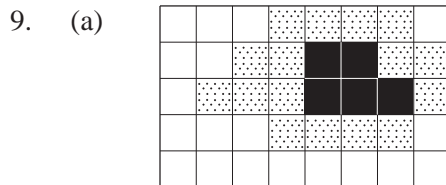

- (b) Towards the top right corner, as there are more pupils in that area.
10. (a) (i) Under 5% (ii) 5–10%
 (b) Risk is greater for men, as there is more of the darker shading in total on the diagram.
 (c) (i) Risk is higher with age
 (ii) Risk is less for non-smokers.

11. (a)

| | | | | | | | |
|---|---|---|---|---|---|---|---|
| 1 | 5 | 6 | 8 | | | | |
| 2 | 1 | 2 | 4 | 4 | 6 | 8 | 9 |
| 3 | 1 | 1 | 2 | 5 | 6 | 7 | 8 |
| 4 | 0 | 1 | 2 | 6 | 9 | | |
| 5 | 1 | 2 | 7 | | | | |

(b) (i) 42 (ii) 32

12. (a)

| | | | | | | | | | | | | | | | | |
|---|---|---|---|---|---|---|---|---|---|---|---|---|---|---|---|---|
| 1 | 5 | 7 | 8 | 8 | 8 | 9 | 9 | | | | | | | | | |
| 2 | 0 | 1 | 1 | 1 | 1 | 2 | 3 | 3 | 3 | 4 | 4 | 5 | 6 | 7 | 7 | 8 |
| 3 | 1 | 2 | 3 | 4 | 5 | 5 | 6 | 7 | | | | | | | | |
| 4 | 0 | 3 | 5 | 5 | 8 | | | | | | | | | | | |
| 5 | 1 | 7 | 8 | | | | | | | | | | | | | |
| 6 | 1 | 2 | 3 | 5 | 5 | 9 | | | | | | | | | | |
| 7 | 1 | 3 | | | | | | | | | | | | | | |
| 8 | 2 | | | | | | | | | | | | | | | |

13.

| | | | | |
|----|---|---|---|---|
| 17 | 0 | 4 | 9 | 9 |
| 18 | 2 | 3 | 5 | |
| 19 | 0 | 5 | 5 | |
| 20 | 1 | 2 | | |
| 21 | 0 | | | |
| 22 | | | | |
| 23 | | | | |
| 24 | 0 | | | |
| 25 | | | | |
| 26 | 3 | | | |
| 27 | | | | |
| 28 | | | | |

For Volume 1, the data is more spread out than for Volume 2, and it has a higher average value.

14. (a) $181^\circ, 93^\circ, 51^\circ, 35^\circ$ (b) 3.14 cm
(d) Total decrease in attendance, but Division 1's share of attendance has increased.
15. (a) 98 (b) $\frac{37}{98}$ (c) $r^2 = 24^2 \times \frac{31}{39}$; $r \approx 21.4$ mm
(e) overall reduction with time, particularly at 'take off'
(f) multiple bar chart – gives better representation of each category, and overall trends.
16. Vertical axis does not start at zero; hence not in proportion to % values.
17. (a) The vertical axis starts at 5 which gives a misleading impression of the overall trends; also the 'Western Europe' group looks similar to the other groups whereas it is in fact much larger.
(b) 1985 (c) 7 (million) (d) 1989
18. (a) 1983 (b) Just over 6 bn Fr.
(c) All improving with SNCF continuing to be more productive than DB, and DB more productive than BR.
(d) The vertical scale does not start at zero, and hence exaggerates productivity.

20.3 Measures of Location and Spread : Box and Whisker Plots

1. (a) A discrete variable has a finite value (e.g. the number of matches in a box).
A continuous variable is not finite and depends on the accuracy of measurement used (e.g. the heights of pupils in a class)
- (b)
$$\begin{array}{l|l} 0 & 3 \ 5 \ 7 \ 8 \ 9 \ 9 \ 9 \ 9 \\ 1 & 0 \ 0 \ 0 \ 0 \ 1 \ 2 \ 3 \ 3 \ 4 \ 5 \ 5 \ 6 \ 6 \ 7 \\ 2 & 0 \ 1 \ 2 \ 3 \ 4 \end{array}$$
- (c) Easy to construct: shows main features of distribution.
- (d) Range 3 to 24; median = 12, LQ = 9, UQ = 16
2.
$$\left. \begin{array}{l} 20\text{th percentile} \Rightarrow 24\text{th value, i.e. } 1.8 \\ 80\text{th percentile} \Rightarrow 96\text{th value, i.e. } 8.0 \end{array} \right\} \text{range} = 6.2$$

The true range (0 to 32) includes outliers, which are not really relevant.
3. (a) (i) 24.7 to 26.4 i.e. 1.7 (ii) $25.3 - 24.6 = 0.7$
(iii) It is far from the other data values.
- (b) Firm C – as it is the only one to meet the requirements.
4. (a) 41 (b) 41 (c) 53 (d) Overall, he scored lower
5. (a)
$$\begin{array}{l|l} 3 & 6 \ 7 \ 7 \ 7 \\ 4 & 2 \ 2 \ 6 \ 8 \ 9 \\ 5 & 1 \ 1 \ 3 \ 3 \ 4 \ 5 \ 6 \ 7 \ 7 \ 8 \\ 6 & 0 \ 2 \ 3 \ 4 \ 8 \\ 7 & 0 \end{array}$$
- (b) (i) 53 (ii) 37
(iii) $70 - 36 = 34$
- (c) The median better represents the average.

- (e) Generally, Monarchs appear to reign longer than Popes, with a similar lower quartile, slightly greater median but significantly greater upper quartile, i.e. stretching to the right.
10. (a) (i) 9.5 (ii) $20 - 7 = 13$ (iii) About 8%
 (b) (i) 8, 52, 67, 76, 83, 120 (ii) 13, 35.5
11. (a) 19 (b) 3 (c) (i) 46 (ii) 27.5, 58.5 (d) Graph (e) 32
 (f)

| <i>Stem</i> | <i>Leaf</i> |
|-------------|-------------|
| 1 | 2 5 8 |
| 3 | 4 |
| 5 | 1 2 7 |

 (g) 27%
12. (a) Graph (b) 7% (c) £14 000
 (d) (i) £18 000 (ii) More variation for women (iii) Excludes extreme values
 (e) (i) £13 300 (ii) No effect
13. (a) Positive (b) 33 minutes (c) 20 (d) 41 minutes
14. (a) Geometric mean = $(105 \times 140 \times 130)^{\frac{1}{3}} \approx 124$ (b) 24

20.4 Weighted Averages : Index Numbers

1. (a) It takes into account relative usage of commodities, so is a fairer representation.
 (b) £500 (c) 117.25
2. (a) 133.33 (b) £14
3. (a) (i) 173.7 (ii) They have all increased by about 75%. (b) 176.0
4. (a) (i) 75 (ii) 150 (b) It remains the same at £400.
5. (a) 120.9 (b) 'All groups' index is less, but is based on many more categories.
 (c) (i) 114.57
 (ii) Reduced, since the 'mortgage' component has index well above 117.79.

20.5 Birth and Death Rates

1. (a) Bangladesh (b) 300 (c) (i) 306 (ii) $\frac{20}{1000} \times 15\,300$
 (d) 50% of expected rate
2. (a) (i) 8 (ii) 6 (b) 17 535 (c) 111
3. (a) 15 (b) different distributions of ages, i.e. older population in Westport

- (c) 19.96
 (d) Westport's population distribution is not the same as the UK as a whole.
4. (a) 10 cm (b) 10, 3, 2, 5, 105
 (c) Adamsville : 24.85; Beckbrough : 13.3
5. (a) $23 \div 12$, $23 \div 52$
 (b) Heathfield : $83 / 6.9 / 1.6$ Joseph : $234 / 19.5 / 4.5$ Garath : $186 / 15.5 / 3.6$
 (c) 14
6. (a) P : 12.54, Q : 21.07
 (b) Town P seems to be a more desirable place to live.
 (c) 113, 108; good efficiency gains from 1986 to 1987.

20.6 Time Series Analysis : Moving Averages

1. (a) Graph (b) Trend line (c) 0.9
 (d) The trend line is based on 1989 – 1994, so 1999 is too far away to predict.
2. (a) Trend line (b) 68
 (c) The 20th week is too far away to make predictions.
3. (a) Underlying decreasing trend (b) Weeks 4 to 5
 (c) (i) 4 (ii) 9 (d) 9.38, 9.20 (e) Graph
4. (a) 1992 (b) Closed for summer holidays (c) Graph
 (d) (i)

| Quarter | Turnover | Moving average |
|---------|----------|----------------|
| 1 | 7500 | 5800 |
| 2 | 5500 | |
| 3 | 2000 | |
| 4 | 8200 | |
| 1 | 6700 | 5600 |
| 2 | 4300 | 5300 |
| 3 | 1600 | 5200 |
| 4 | 8200 | 5200 |
| 1 | 5100 | 4800 |
| 2 | 3900 | 4700 |
| 3 | 1200 | 4600 |
| 4 | 7500 | 4425 |

- (ii) Graph
 (iii) The underlying trend is downward.

5. (a) Graph (b) Spring/Summer time gives a boost to sales.

(c)

| Year | Quarter | Sales £10 000's | Four-point moving average |
|------|---------|--------------------|------------------------------|
| 1992 | 1 | 20 | |
| | 2 | 26 | |
| | 3 | 24 | 22 |
| | 4 | 18 | 23 |
| 1993 | 1 | 24 | 24 |
| | 2 | 30 | 24.75 |
| | 3 | 27 | 26 |
| | 4 | 23 | 26.5 |
| 1994 | 1 | 26 | 27.5 |
| | 2 | 34 | 28.5 |
| | 3 | 31 | 29 |
| | 4 | 25 | 30 |
| 1995 | 1 | 30 | 30.5 |
| | 2 | 36 | 31.5 |
| | 3 | 35 | 32.5 |
| | 4 | 29 | |

- (d) Graph (e) Trend line (f) 33
6. (a) Graph
 (b) 1st quarter is lowest; increase up to 3rd quarter; decrease in last quarter.
 (c) If repeated in August and September, this would give 5.4 million passengers – you might though expect more passengers in July and less in September.

20.7 Correlation and Regression

1. B : positive correlation ; A : negative correlation ; C : no correlation
2. (a) E : 1600 cc ; F : 26 miles per gallon ; H : 2000 cc, 27 miles per gallon
 (b) Diagram (c) G – it is well below a line of best fit.
3. (a) Diagram (b) (i) About 12.30 pm (ii) 38.5 °C (c) About 6.35 pm
4. (b) 08.30, 21.15 (c) 01.00, 12.10
5. (a) and (c) Drawings (b) 27.5 kg (d) $3.4x + 1.6$ (e) 28.8 kg
 (f) Small sample size

6. (a)

| | A | B | C | D | E | F |
|-------------|---|------|---|------|----|----|
| Rank Time | 3 | 5 | 2 | 4 | 1 | 6 |
| Rank errors | 4 | 2.5 | 5 | 2.5 | 6 | 1 |
| d | 1 | 2.5 | 3 | 1.5 | 5 | 5 |
| d^2 | 1 | 6.25 | 9 | 2.25 | 25 | 25 |

- (b) $\sum d^2 = 68.5$ and $r = -0.957$ (c) Quite fast and not too many errors.

7. (a) 0.006
 (b) Small but positive correlation, giving some support to the hypothesis.
 (c) Beer does not improve with age.

8. (a)

| <i>Club</i> | <i>A</i> | <i>B</i> | <i>C</i> | <i>D</i> | <i>E</i> | <i>F</i> | <i>G</i> | <i>H</i> |
|----------------------------------|----------|----------|----------|----------|----------|----------|----------|----------|
| Position in league | 1 | 3 | 6 | 2 | 7 | 8 | 5 | 4 |
| Average attendance | 34 | 12 | 18 | 32 | 15 | 25 | 27 | 19 |
| Rank of attendance | 1 | 8 | 6 | 2 | 7 | 4 | 3 | 5 |
| Difference in ranks (<i>d</i>) | 0 | 5 | 0 | 0 | 0 | 4 | 2 | 1 |
| d^2 | 0 | 25 | 0 | 0 | 0 | 16 | 4 | 1 |

- (b) 0.45 (c) Some positive correlation
 (d) Very positive correlation
9. (a) 29% (b) Graph (c) 5.5 cm (d) Graph
 (e) (i) 8.2 cm (ii) 17.5 cm
 (f) Answer (i); lies in the range of chosen values for AB.

20.8 Distributions

1. (a) 122, 122, 122
 (b) (i) Identical (ii) On standardised scoring, all three are equivalent.
2. (a) Graph
 (b) Using mean 0 and s.d. 1, the standardised scores are
 History : 2 Physics : 1.5
 So this supports her claim.
3. (a) 5.5 (b) 0.76 (c) (i) 0.395 (ii) 5.7
 (d) (i) 3.0 (ii) Mean value increases, s.d. decreases
4. (a) Median
5. (a) TTT, TTH, THT, HTT, THH, HTH, HHT, HHH
 (b) $\frac{1}{8}$ (c) $\frac{1}{2}$ (d) $\frac{1}{4}$
6. (a) 47 (b) Graph
7. Mean 120 cm; s.d. 3 cm
8. (a) Frequencies: 12, 40, 24, 15, 9
 (b) Graph
 (c) (i) 17.2 (ii) 8.5 lb
 (iii) Not likely; largest fish in frequency table ≤ 15 lb.

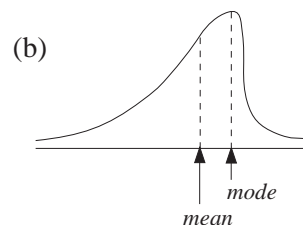

9. (a) (i) Too long (ii) Too expensive
- (b) $417 \pm 3 \times 0.6 = 417 \pm 1.8$
 $= 418.8$ or 415.2
 i.e. (415.2, 418.8)
- (c) This ensures that more than 99.8% weigh more than 415 g.
- (d) The process should be checked after 4 hours (sample 8) and $5\frac{1}{2}$ hours (sample 11), as both are outside the allowable limits.
10. (a) $1 + 6, 2 + 5, 3 + 4, 4 + 3, 5 + 2, 6 + 1$
- (b) $\frac{6}{36} = \frac{1}{6}$
- (c) $80 \times \frac{1}{6} \approx 13$
- (d) $p = \frac{7}{9}$
- $$p(X=2) = 3 \times \left(\frac{7}{9}\right)^2 \times \frac{2}{9} = \frac{98}{243}$$
- (e) The probability stays the same for each throw.
- (f) She will get better with more throws.
11. (a)

| | | | | | | | | | | | | | | | | | | | |
|---|---|---|---|---|---|---|---|---|---|---|---|---|---|---|---|---|---|---|---|
| 4 | 3 | 8 | 2 | 7 | 2 | 6 | 8 | 9 | 3 | 2 | 1 | 5 | 0 | 0 | 8 | 5 | 2 | 2 | 6 |
| G | G | R | B | R | B | Y | R | R | G | B | B | Y | P | P | R | Y | B | B | Y |
- (b) (i) $p(R) = \frac{5}{20} = \frac{1}{4}$
- (ii) $100 \times \frac{1}{4} = 25$
- (c) If the simulation is carried out 1000 times the probability might be slightly more than $\frac{1}{4}$ as the angle of Red on the spinner is greater than 90° .